

Safe connections for transformer construction

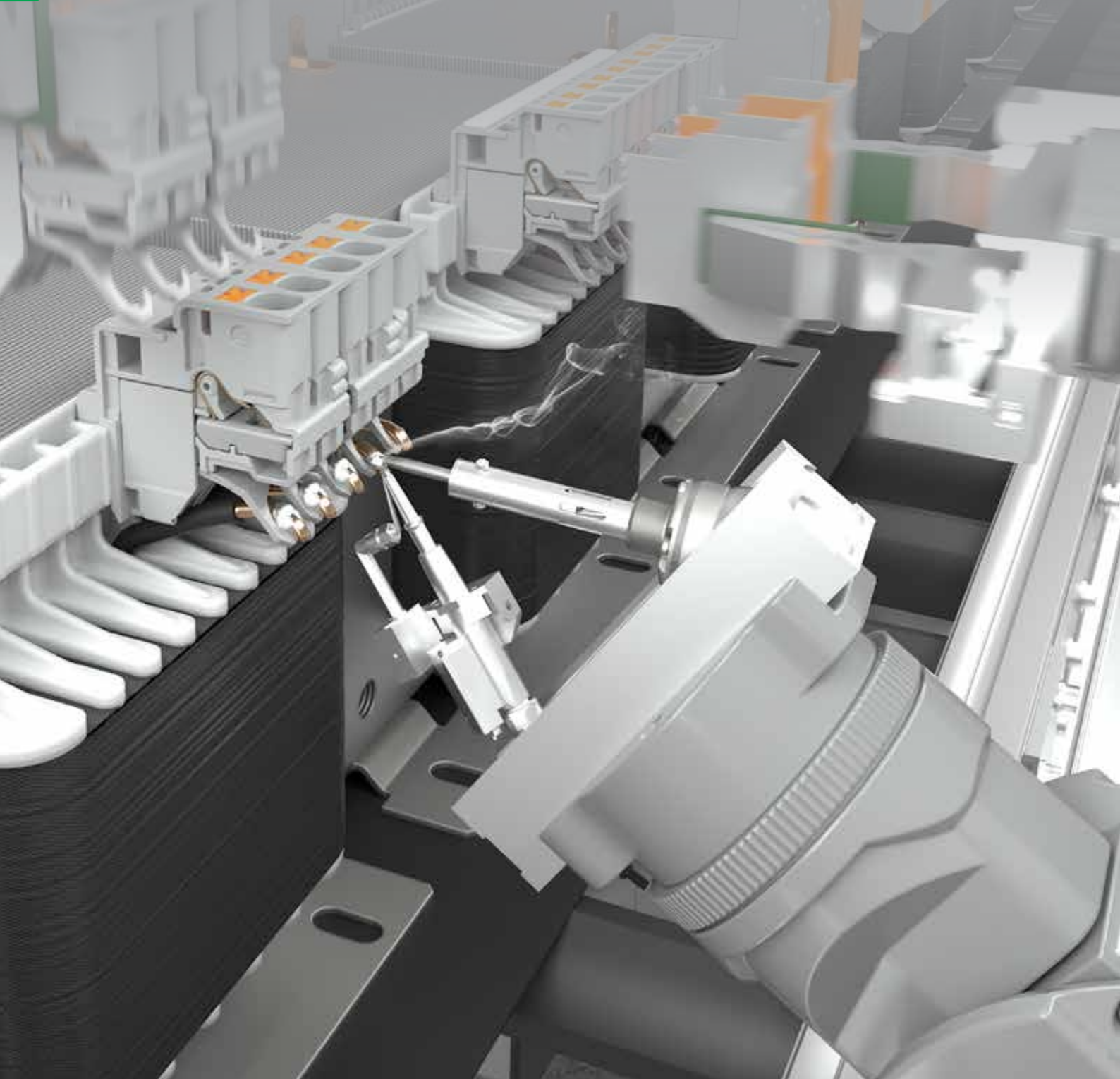



Contents

Our company	3
Digitally on the move	4
Active worldwide	5
Our catalogue system	6
Transformer terminals PTKS 4/PTKS 4/SI	8
Transformer terminals TKS/TK	16
Screw connection system SRK/SSL	28
Feed-through terminals RK/Measurement pick-off terminals MAG	44
Stud connection system HSK	52
Stud terminal system HSKG	62
Types and order numbers	72



CONTA-CLIP: Because progress needs an impulse

Since 1978, CONTA-CLIP has stood for electrical and electronic connection technology and for reliable products: For over 40 years, our components and solutions have been used in process and industrial automation applications, including: railway technology, materials handling, building automation, air conditioning, mechanical and facility engineering, measurement and control technology, control panel construction, shipbuilding, transformer construction and environmental technology.

As an owner-operated medium-sized company, CONTA-CLIP is today one of the most important manufacturers in this sector - an innovator with global market and industry expertise.

Based on communication among equals, our employees develop solutions for your specific requirements and industry, and we have also designed our range of services to align with customer needs. This results in first-class products where quality has the highest priority.

We design customer-specific solutions for electronics, provide completely assembled housings and assemblies as needed, assemble terminal block assemblies for series production, take over the labelling of components - and all of this in the shortest possible time

Our products are divided into six categories: CONTA-CONNECT for terminal blocks and accessories, CONTA-CABLE cable management systems, CONTA-ELECTRONICS for electrical and electronic electrical cabinet components, CONTA-LABEL for marking systems, CONTA-BOX for housings, and CONTA-CON for PCB terminal blocks and connectors.

And last but not least, your personal CONTA-CLIP contact persons are always available to answer any questions you may have: we look forward to getting in touch with you.

Digitally on the move: The online catalogue is there

Find the right product using the search function, the order number or the "step-by-step-search" search feature. After selecting a product, all product master data, i.e. commercial data, technical data, drawings, connection diagrams, classifications and approvals are available to you as a data sheet or export file. You can send detailed inquiries about components via the shopping cart directly to our headquarters. Complex functionalities are explained clearly in our application films.

Would you prefer to get information offline? You can request all our catalogues in print form here free of charge.

Always stay up-to-date with our newsletter: Simply register and you will be informed about all CONTA-CLIP news.

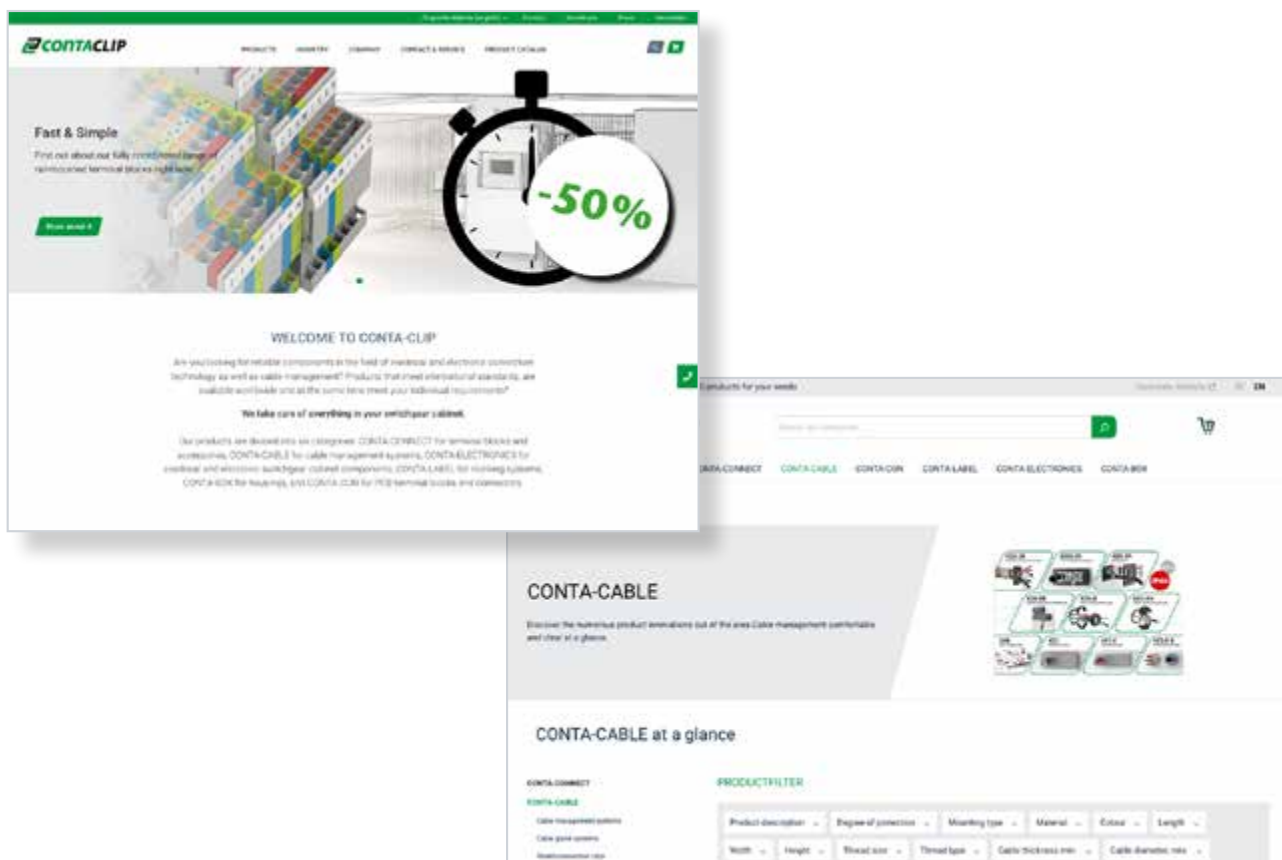

Active worldwide: Here we are present

CONTA-CLIP stands for the best connection technology and reliable products - worldwide. Our worldwide sales and distribution partners help us to be globally networked and provide on-time reliable deliveries.

Are you working abroad? You can find the sales partner responsible for your country via our website.



Our locations in Africa

Algeria
Morocco
South Africa

Our locations in Asia

Bahrain
China
Hong Kong
India
Israel
Japan
Jordan
Malaysia
Oman
Pakistan
Qatar
Saudi Arabia
Singapore
South Korea
Taiwan
Turkey
United Arab Emirates

Our locations in Oceania

Australia
New Zealand

Our locations in Europe

Austria
Belarus
Belgium
Bulgaria
Croatia
Czech Republic
Denmark
Finland
France
Germany
Great Britain
Greece
Hungary
Iceland
Ireland
Italy
Latvia
Netherlands
Norway

Poland
Portugal
Romania
Serbia
Slovakia
Slovenia
Spain
Sweden
Switzerland
Ukraine

Our locations in North America

Canada
Mexico
United States

Our locations in South America

Bolivia
Brazil
Chile
Columbia
Ecuador

Our catalogue system

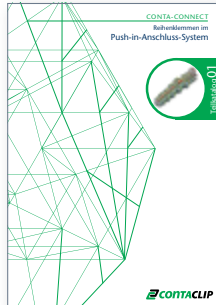

- 01 CONTA-CONNECT**
Terminal blocks with Push-in connection system
 Our wide range of innovative PRK and FRK terminal blocks with the Push-in connection system include feed-through terminals, PE terminals, disconnect terminals, fused terminals, multi-level terminals, installation terminals and initiator terminals, for conductor cross-sections from 0.2 mm² to 25 mm².
Cat. no. 98070.2

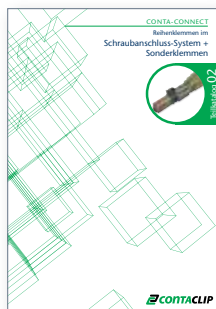

- 02 CONTA-CONNECT**
Terminal blocks with screw connection system and special purpose terminals
 Everything for classic wiring with screw connection system, also for high currents: SRK feed-through and PE terminals, RK high-temperature variants, TK transformer terminals, HSK high-power stud terminals and the SVB series screw distributor blocks.
Cat. no. 98071.2

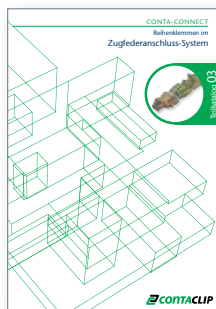

- 03 CONTA-CONNECT**
Terminal blocks with tension-spring connection system
 Our versatile line of terminals with tension spring connections for conductor cross-sections from 0.2 mm² to 16 mm² includes: the ZRK/ZSL series of feed-through and PE terminals, the double-level ZRKD/ZSLD, the ZIKD three-level terminal blocks, motor-connection terminals, (blade-) disconnect terminals, fused terminals, direct-mount terminals, and initiator/actuator terminals for transmitting positioning, encoder and alert signals.
Cat. no. 98072.2



- 04 CONTA-CONNECT**
Installation materials and other accessories for terminal blocks
 Our installation products include cabling ducts, assembly tools, cable glands with metric or PG threads, DIN rails, rail cutters and punching tools. The terminal block accessories include different versions of end stops, wire-end ferrules, and connectors.
Cat. no. 98073.2

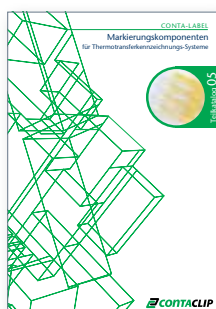

- 05 CONTA-LABEL**
Marking components for thermal-transfer marking systems
 CONTA-CLIP provides the TTPCard thermal-transfer printer and a large selection of PC, PVC and PVCF markers or labels in card format: for professional, permanent labelling of terminals, devices, conductors, cables, facilities and electrical cabinets.
Cat. no. 98074.2

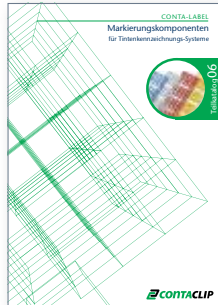
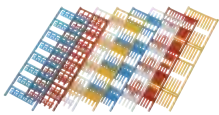

06 CONTA-LABEL
Marking components for ink-based marking systems
 The CONTA-LABEL products provide polyamide markers for labelling conductors, cables, devices and facilities with ink print. These markers are available in many shapes and colours: in the classic MC Maxi-Card format for self-printing with the EMS plotter system EMS or other ink-jet systems, or ready-to-use customised printed in the PMC Pocket-Maxi-Card format.
Cat. no. 98075.2

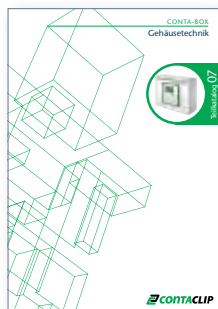

07 CONTA-BOX
Housings
 Our wide variety of housings made of polystyrene, polycarbonate, polyester, ABS and aluminium deliver solutions for protecting electronic circuits, integrated devices and terminal blocks. On request, these housings can be custom-processed and assembled with our CONTA-CONNECT, CONTA-ELECTRONICS and CONTA-CON products.
Cat. no. 98076.2



08 CONTA-CABLE
KDS cable entries, KES cable entries, SAB/SSAB/SABK shielding solutions
 The KDS and KES cable entries enable a tool-free, IP66-sealed feed-through for unassembled and assembled cables and hoses. The feed-through openings can be adapted at any time to meet your requirements. The SAB shield-connection clips can be used to provide a reliable shield contact with wire diameters from 3 mm to 35 mm.
Cat. no. 98077.2

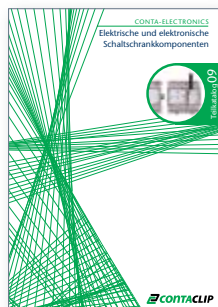

09 CONTA-ELECTRONICS
Electrical and electronic cabinet components
 Our CONTA-ELECTRONICS products provide active and passive components for the transfer and conversion of analogue and digital signals at the coupling level. This product line includes power supplies, multi-function timing relays, coupling relays, digital switching modules, interface modules, opto-couplers, signal converters, GSM communication modules and much more.
Cat. no. 98078.2

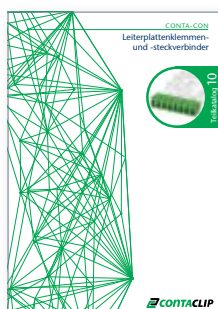
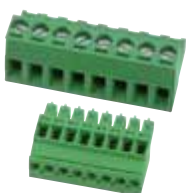

10 CONTA-CON
PCB terminals and connectors
 This catalogue presents CONTA-CON's wide range of PCB terminals and plug-in connector systems, as well as the modular feed-through terminal systems of the SDK series. The modular components can be configured for any required number of poles. They are available in the wire connection types: wire protection, eccentric, clamping yoke, and (for demanding operating conditions) with tension-spring or Push-in wire terminations.
Cat. no. 98079.2

With us,
quality is in
every detail: **The new
transformer terminals
PTKS 4 | PTKS 4/SI**

With attention to detail, we work on innovations every day to offer you the best connection technology for your transformers:
Our new **PTKS 4** transformer terminals with push-in connection principle make wiring your transformers easier and faster than ever before, completely without tools.



- **Wiring in seconds** thanks to the innovative push-in connection, without tools and without screws
- **Easy handling** and time saving during assembly
- **Reliability** through permanent contacting even under shock and vibration loads
- **Fast disconnecting** with only one press of the pusher

Strong connection with one click: **Transformer terminals PTKS 4 | PTKS 4/SI**



Push-in wire
connection

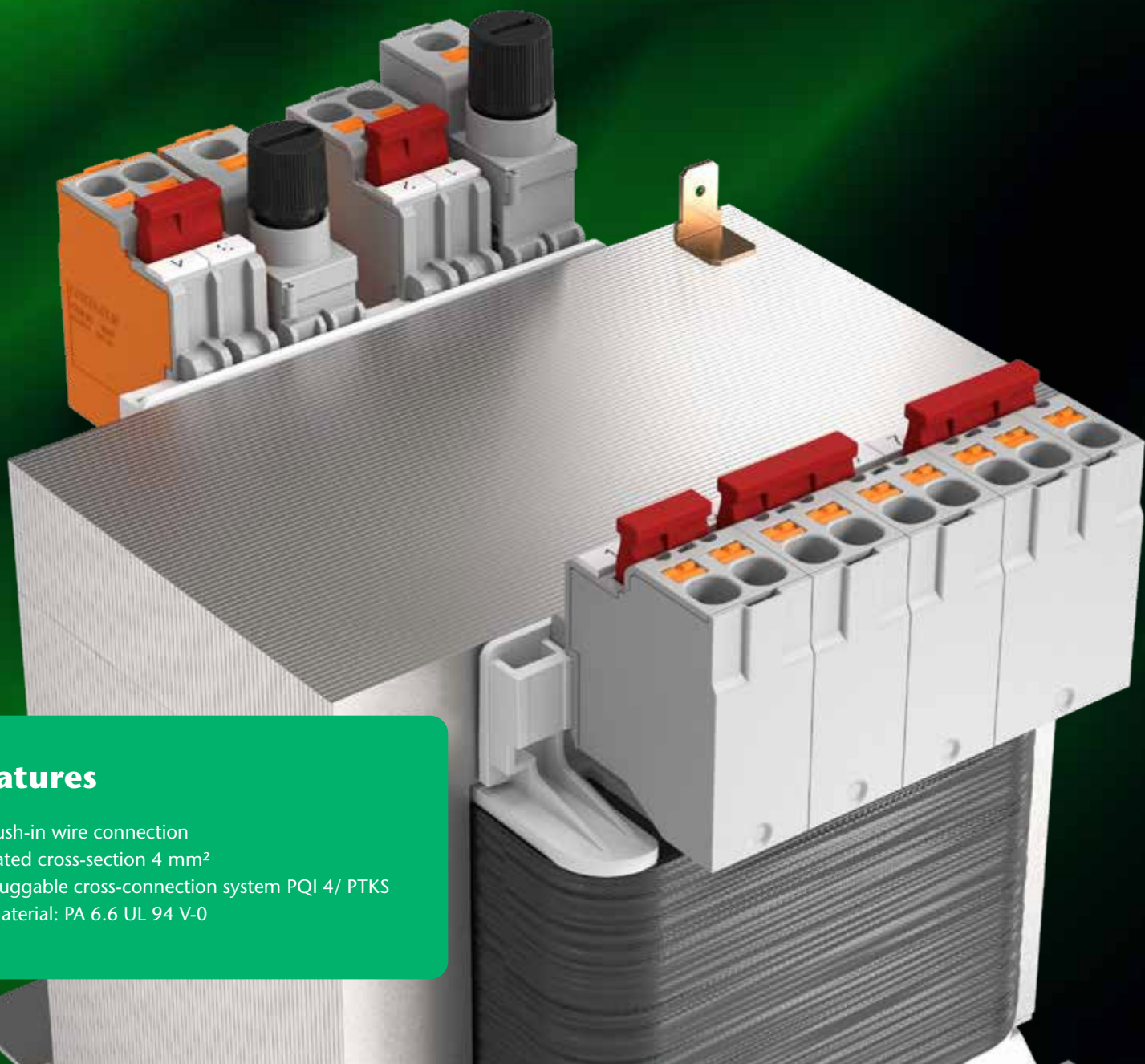

Features

- Push-in wire connection
- Rated cross-section 4 mm²
- Pluggable cross-connection system PQI 4/ PTKS
- Material: PA 6.6 UL 94 V-0

There are numerous convincing advantages to our **PTKS 4**: With their particularly easy handling and time-saving assembly, they contribute significantly to increasing efficiency and safety. The cross-connectable **PTKS 4** transformer terminals are intended to be directly mounted to a coil body with the integrated receptacles. They can also be mounted on aluminium 10 x 2mm DIN rails. They are used for converting coil ends to push-in connections, for connecting to the device being powered or to parts of the facility.

The push-in terminal can be easily connected with a wire from above. Making a connection takes only seconds. The connection of adjacent terminals is just as quick and convenient with pluggable, insulated **PQI 4/x/PTKS** cross-connectors. The connection of rigid conductors and conductors with and without wire-end ferrules is guaranteed and only the orange pusher has to be pressed to remove the wire.

The **PTKS 4/SI 5 x 20** and **PTKS 4/SI 6.3 x 32** transformer fused terminals can have a corresponding 5 x 20 mm or 6.3 x 32 mm micro-fuse inserted into them through the proven screw cap.

Not only do you gain a great time advantage during the wiring process, but the push-in terminals are also particularly safe and can be used under adverse conditions, as nothing can come loose even when subjected to shock and vibration. Our push-in terminals can withstand these loads with guaranteed permanent contacting

Advantages for end customers:

- Innovation in the field of transformer terminals
- Push-in connection
- Less insertion force
- Time saving when contacting the wires
- Wire insertion requires no tools
- Built-in insulated pusher for disconnecting the wire
- Test pick-off at each potential

Advantages for users during the development:

- Innovation in the field of transformer terminals
- Push-in connection
- Reduced inventory due to modular design
- Different voltages can be identified by different coloured hoods
- Marking by marking nails or laser marking possible

Advantages for users during production:

- Free accessibility of the soldering point (also in quality control)
- Subsequent insertion of cross-connectors (star-delta)
- Wave soldering, robotics and hand soldering possible
- Different voltages can be identified by different coloured hoods
- Marking by marking nails or laser marking possible

The features in detail

Design of the terminal

The **PTKS 4** consists of separate terminal bodies and a snap-on protective hood. By retrofitting the protective hoods which make the soldering hooks freely accessible, the coil wires can be soldered on in a convenient time-saving manner. The basic terminals are available in 1-pole and 2-pole, the protective hoods are ordered separately in 2-pole and 3-pole. The modular design leads to a very high flexibility with very low inventory.

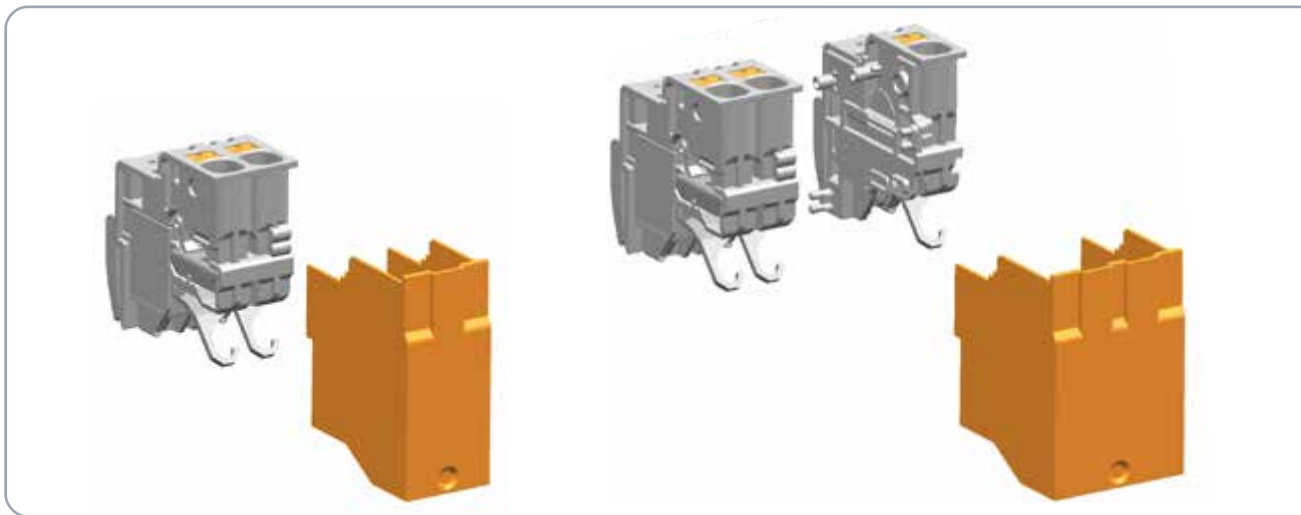

Protective hoods

By retrofitting the protective hoods, the soldering hooks are freely accessible at all times during the production process. This makes it possible to use the **PTKS 4/x** in various manufacturing processes (wave soldering, robotics and hand soldering). The separately orderable 2- and 3-pole **PTKS-ADH 4/x** protective hoods are available in different colours. This way, different voltages or windings can be marked easily and quickly.



Modular design for even numbers of poles

Even numbers of poles on the transformer only require 2-pole terminals to be used with the 2-pole protective hoods.



Modular design for odd numbers of poles

By retrofitting the protective hoods, the soldering hooks are freely accessible at all times during the production process. This makes it possible to use the **PTKS 4/x** in various manufacturing processes (wave soldering, robotics and hand soldering). The separately orderable 2- and 3-pole **PTKS-ADH 4/x** protective hoods are available in different colours. This way, different voltages or windings can be marked easily and quickly.

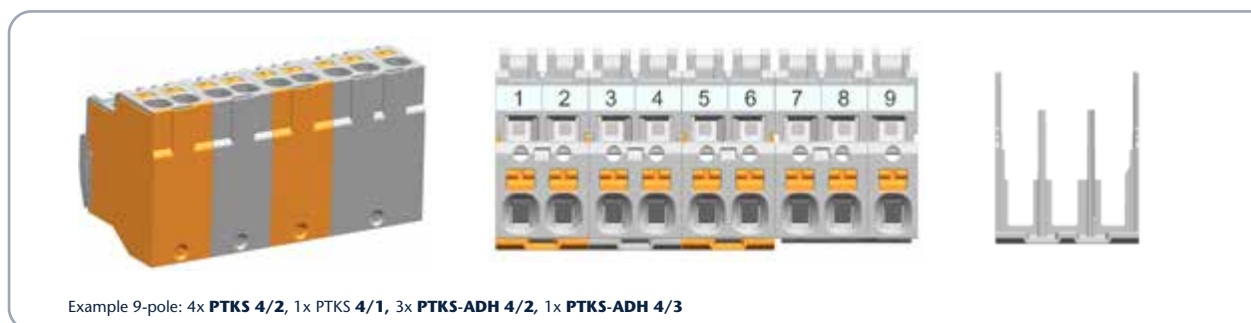



Additional accessories

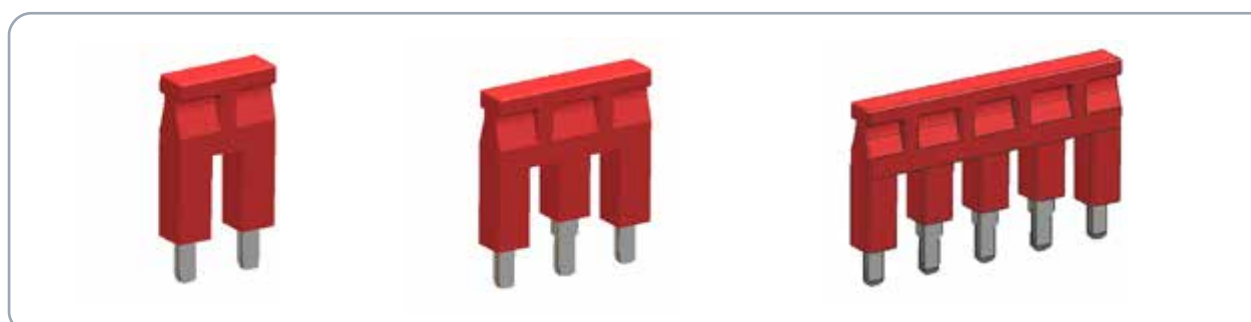

The insulated and pluggable **PQI 4/x/PTKS** cross-connectors enable quick and convenient distribution of potentials and are available in 2-, 3- and 5-pole versions. Potential connections can be multiplied quickly, safely and cost-effectively using the cross-connectors. The transformer terminals can be labelled or marked as usual using the PMC SB 7.5 quick marking system. In addition, direct laser marking is possible.

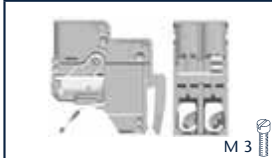

Transformer terminals PTKS

Push-in wire connection		PTKS 4/1			PTKS 4/2		
<ul style="list-style-type: none"> Housing made of polyamide 6.6 UL 94 V-0 							
Connection diagram							
Description		Transformer terminal 1 push-in connection			Transformer terminal 2 push-in connections		
Wire connect type		Push-in technique			Push-in technique		
Size (L x W x H), mm		30.7 x 8.1 x 31.5			30.7 x 15.0 x 31.5		
Type / colour		PTKS 4/1 GR ●			PTKS 4/2 GR ●		
Cat. no.	Qty.	27080.6	50	27081.6	25		
Ratings		IEC*	UL*	CSA*	IEC*	UL*	CSA*
Rated voltage (V)		800	600	600	800	600	600
Rated current (A)		32	27	27	32	27	27
Rated wire cross-section, mm ² / AWG		4 / 20–10			4 / 20–10		
Rated surge voltage kV / Contamination degree		8 / 3			8 / 3		
Plug gauge acc. to EN 60 947-1 / Flamm. class acc. to UL 94		A4 / V-0			A4 / V-0		
Connection data							
Single wire (solid) / stranded (flexible), mm ²		0.5–6 / -			0.5–6 / -		
Finely-stranded / finely-stranded (w/ferrules acc. to DIN 46228/1), mm ²		0.5–4 / 0.5–4			0.5–4 / 0.5–4		
Clamping range, mm ²		0.5–4			0.5–4		
Stripping length, mm		12			12		
Features							
Material of insulated housing Temperature range		PA 6.6 / -40 °C to +120 °C			PA 6.6 / -40 °C to +120 °C		
Number of cross-connection channels / Test pick-off option		1 / 1			1 / 2		
Accessories							
Quick marking PMC SB		PMC SB 7.5/40 WH			PMC SB 7.5/40 WH		
Cat. no.	Qty.	9326.7	400	9326.7	400		
Quick marking PMC SB, special print		PMC SB 7.5/40 So WH			PMC SB 7.5/40 So WH		
Cat. no.	Qty.	3327.7	400	3327.7	400		
Screwdriver SDB		SDB 0.5 x 3.0			SDB 0.5 x 3.0		
Cat. no.	Qty.	1085.0	1	1085.0	1		
Protective hood PTKS-ADH 2-pole.					PTKS-ADH 4/2 OG		
Cat. no.	Qty.			27082.3	50		
Protective hood PTKS-ADH 2-pole.					PTKS-ADH 4/2 GR		
Cat. no.	Qty.			27082.6	50		
Protective hood PTKS-ADH 3-pole.		PTKS-ADH 4/3 OG			PTKS-ADH 4/3 OG		
Cat. no.	Qty.	27083.3	50	27083.3	50		
Protective hood PTKS-ADH 3-pole.		PTKS-ADH 4/3 GR			PTKS-ADH 4/3 GR		
Cat. no.	Qty.	27083.6	50	27083.6	50		
Insulated cross-connection PQI		PQI 4/2/PTKS RD			PQI 4/2/PTKS RD		
Cat. no.	Qty.	27084.9	50	27084.9	50		
Insulated cross-connection PQI		PQI 4/3/PTKS RD			PQI 4/3/PTKS RD		
Cat. no.	Qty.	27085.9	50	27085.9	50		
Insulated cross-connection PQI		PQI 4/5/PTKS RD			PQI 4/5/PTKS RD		
Cat. no.	Qty.	27086.9	20	27086.9	20		

* Approvals are pending

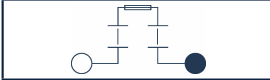
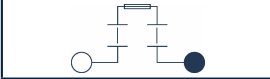
Push-in wire connection	PTKS 4/SI 5 x 20	PTKS 4/SI 6.3 x 32
<ul style="list-style-type: none"> Housing made of polyamide 6.6 UL 94 V-0 		
Connection diagram		
Description	Transformer-fused terminal 1 push-in connection	Transformer-fused terminal 1 push-in connection
Wire connect type	Push-in technique	Push-in technique
Size (L x W x H), mm	32.5 x 12.5 x 43.9	32.5 x 12.5 x 49.4
Type / colour	PTKS 4/SI 5 x 20 GR ●	PTKS 4/SI 6.3 x 32 GR ●
<i>Cat. no.</i>	27087.6	27088.6
Qty.	50	50
Ratings	IEC* UL* CSA*	IEC* UL* CSA*
Rated voltage (V)	250 600 600	500 600 600
Rated current (A)	10** 10 10	10** 10 10
Rated wire cross-section, mm ² / AWG	4 / 20 – 10	4 / 20 – 10
Rated surge voltage kV / Contamination degree	8 / 3	8 / 3
Plug gauge acc. to EN 60 947-1 / Flamm. class acc. to UL 94	A4 / V-0	A4 / V-0
Connection data		
Single wire (solid) / stranded (flexible), mm ²	0.5 – 6 / -	0.5 – 6 / -
Finely-stranded / finely-stranded (w/ferrules acc. to DIN 46228/1), mm ²	0.5 – 4 / 0.5 – 4	0.5 – 6 / 0.5 – 4
Clamping range, mm ²	0.5 – 4	0.5 – 6
Stripping length, mm	12	12
Features		
Material of insulated housing Temperature range	PA 6.6 / -40 °C to +120 °C	PA 6.6 / -40 °C to +120 °C
Number of cross-connection channels / Test pick-off option		
Accessories		
Quick marking PMC SB		
<i>Cat. no.</i>		
Quick marking PMC SB, special print		
<i>Cat. no.</i>		
Screwdriver SDB	SDB 0.5 x 3.0	SDB 0.5 x 3.0
<i>Cat. no.</i>	1085.0	1085.0
Qty.	1	1
Protective hood PTKS 4	PTKS-ADH 4/SI 5 x 20 OG	PTKS-ADH 4/SI 6.3 x 32 OG
<i>Cat. no.</i>	27089.3	27090.3
Qty.	50	50
Protective hood PTKS4	PTKS-ADH 4/SI 5 x 20 GR	PTKS-ADH 4/SI 6.3 x 32 GR
<i>Cat. no.</i>	27089.6	27090.6
Qty.	50	50

* Approvals are pending
 ** depending on the type of fuse in use.

Open up flexible installation options: **Our transformer terminals TKS/TK**

The extensive range of our transformer terminals opens up different mounting variations and thus a wide range of possible applications - not least thanks to the proven connection system.



- **Simple and time-saving handling** due to direct mounting on the coil body
- **Adaptable** for screw and spade terminals
- **Vibration-resistant connection** due to the clamping yoke system used millions of times over
- **High contact force and contact reliability** in practical use

Time-saving installation,
robust in use:

The transformer terminals TKS/TK

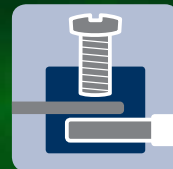

Screw connection
system

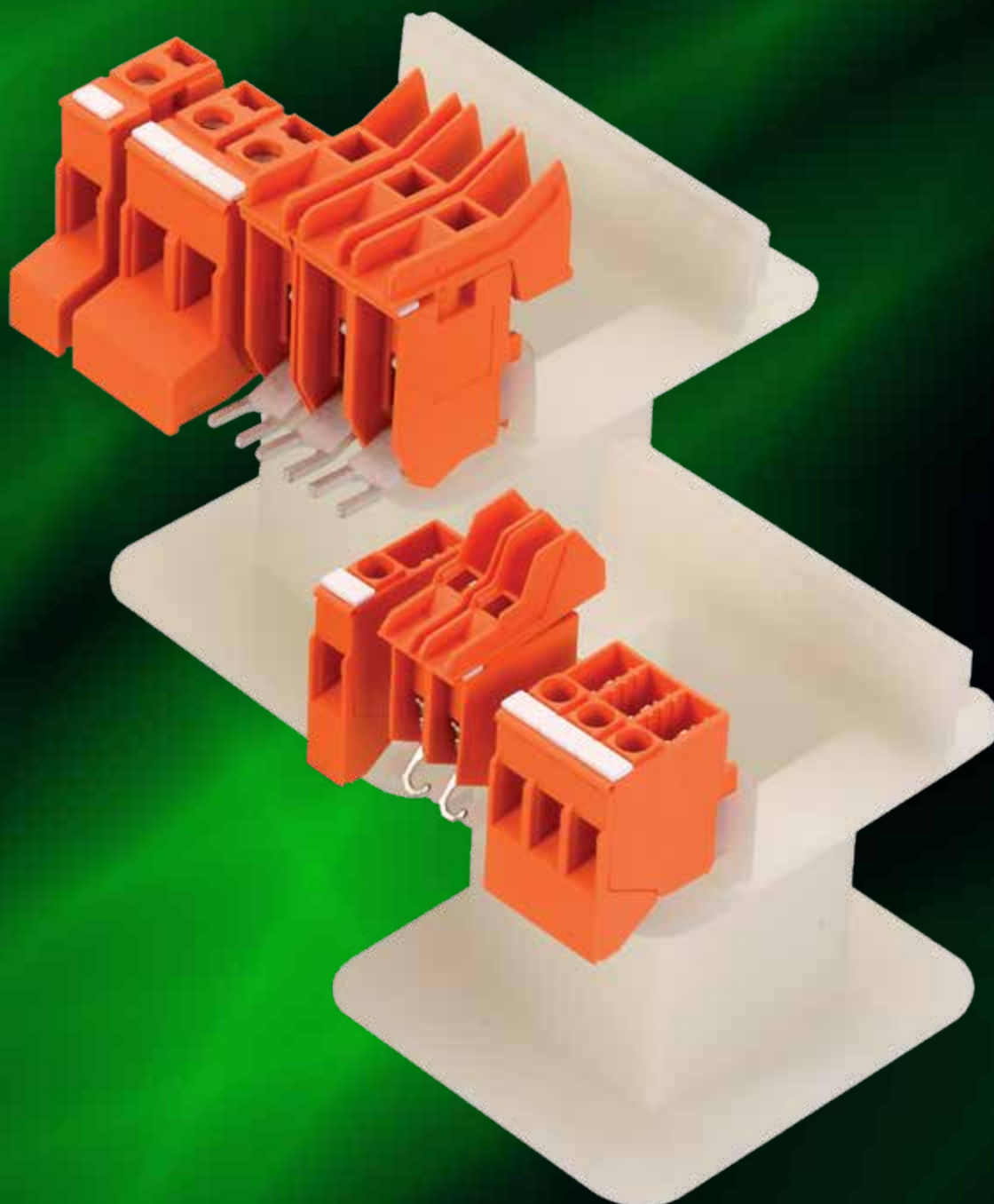

The **TKS/TK** transformer terminals are intended to be directly mounted to a coil body with integrated receptacles. They can also be mounted on aluminium 10 x 2 DIN rails. They are used for converting coil ends to screw-/spade connections, for connection to the device being supplied, or to parts of the facility.

All transformer terminals feature the proven clamping yoke system which guarantees a vibration-resistant connection. Touch safety in compliance with the German accident prevention regulation (DGUV-3) is ensured because of the closed housing design (material is polyamide PA 6.6 UL 94 V-0).

The **PMC SB 7.5** quick marking system is used for labelling the transformer terminals.

The advantages:

- A connection mechanism that has proven itself in billions of applications
- Connection of multiple wires is possible
- Comprehensive product line
- Easy to mount to cores
- Convenient marking options

Features:

- Screw connection system
- Transformer terminals from 4 to 16 mm²
- High contact force and contact security
- Material: PA 6.6 UL 94 V-0

The features in detail

Transformer terminals: TKS 4 and TKS 4/F

The **TKS 4** and **TKS 4/F** are available as 1-, 2-, and 3-pole units in the standard orange and grey colours. Customer-specific colours are available upon request. Available are the **TKS 4** screw connection and the **TKS 4/F** screw-/spade connection (2.8/6.3 mm). The screw connection is designed for wires up to 4 mm². The solder hook is open-sided and the housing lid clips back in the open position above the screwdriver insertion point. These two factors allow the coil wires to be conveniently and quickly soldered.

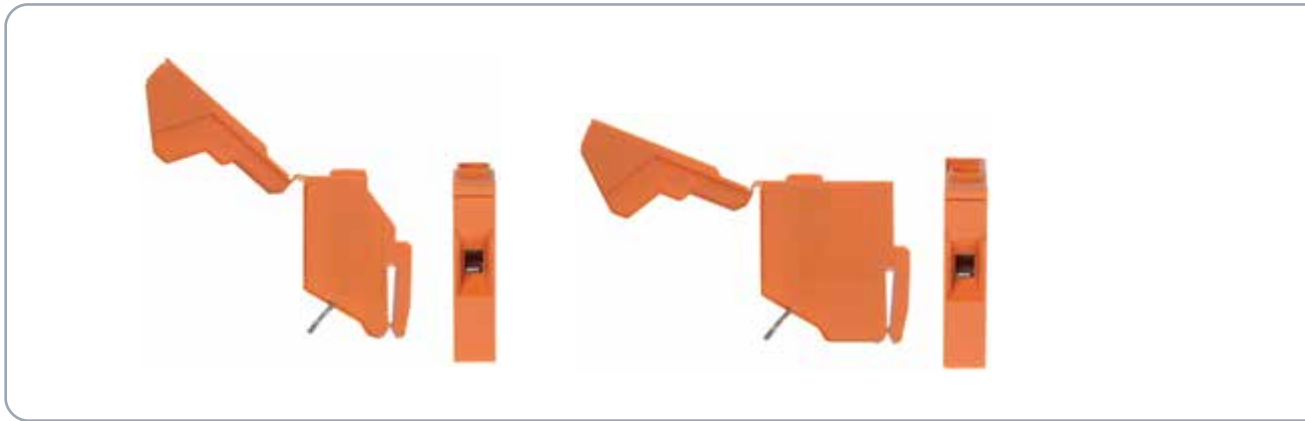

Transformer terminals TKS 10 and TKS 16/2

The **TKS 10**s are available as 1-, 2-, and 3-pole versions. The **TKS 16** is available in a 2-pole block version in the standard colours orange and grey. Customer-specific colours are available upon request. The screw connection is designed for wires up to 16 mm². The solder hook is open and the housing lid clips back in the open position above the screwdriver insertion point. These two factors allow the coil wires to be conveniently and quickly soldered.



Transformer-fused terminals TKS 4 SI 5 x 20, 5 x 25 and 6.3 x 32

The **TKS 4 SI** are available in 1-pole versions in the standard colours orange and grey. The screw connection is designed for wires up to 4 mm². A screw cap is used to attach the corresponding 5 x 20, 5 x 25 or 6.3 x 32 micro-fuses in the **TKS 4 SI**.







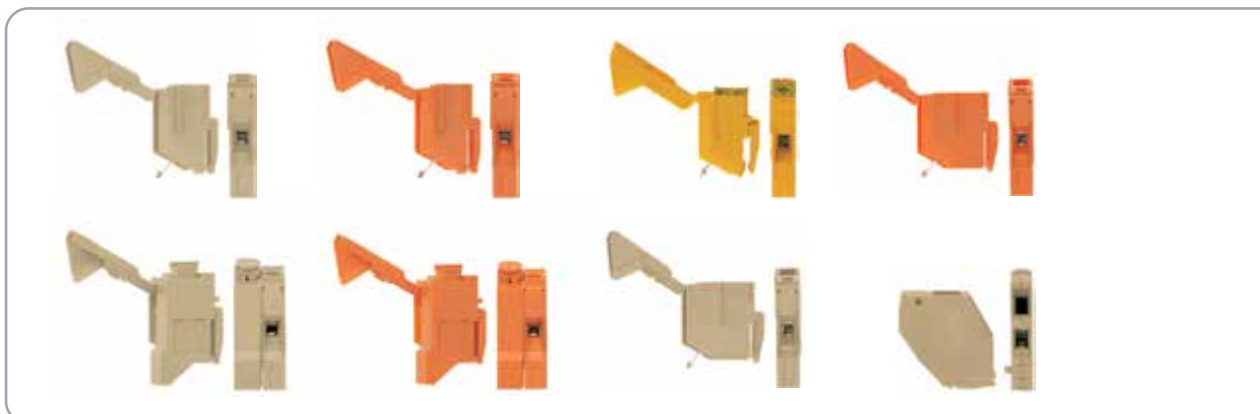

Transformer terminals TK 4, TK 4/F, TK 10 and TK 4 SI







This modular system uses a dove-tail connection to assemble together into the required number of poles. The transformer terminals can also be delivered pre-assembled, in standard units from 2 to 10 poles and in orange or beige. Customer-specific colours are available upon request.

The **TK 4** screw connection and the **TK 4/F** screw-/spade connection are available in colour versions (2.8/6.3 mm). The screw connection is designed for wires up to 4 mm². The housing for the **TK 10** transformer terminals (10 mm²) and the **TK 4 SI** transformer fused terminals (4 mm²) are designed as single-pole terminals without a dove-tail connection. A plug-in unit is used to attach the corresponding 5 x 20 or 5 x 25 micro-fuses in the **TKS 4 SI**.













Transformer terminals TKS

Screw connection system		TKS 4/1	TKS 4/2	TKS 4/3
<ul style="list-style-type: none"> Housing made of polyamide 6.6 UL 94 V-0 				
Connection diagram				
Description		Transformer terminal 1 screw connection	Transformer terminal 2 screw connections	Transformer terminal 3 screw connections
Wire connect type		Screw connection technology	Screw connection technology	Screw connection technology
Size (L x W x H), mm		20.5 x 7.5 x 33.1	20.5 x 7.5 x 33.1	20.5 x 7.5 x 33.1
Type / colour		TKS 4/1 OG ●	TKS 4/2 OG ●	TKS 4/3 OG ●
Cat. no.	Qty.	1222.3 50	1223.3 25	1224.3 20
Type / colour		TKS 4/1 GR ●	TKS 4/2 GR ●	TKS 4/3 GR ●
Cat. no.	Qty.	1222.6 50	1223.6 25	1224.6 20
Ratings		IEC UL CSA	IEC UL CSA	IEC UL CSA
Rated voltage (V)		800 600 600	800 600 600	800 600 600
Rated current (A)		32 27 27	32 27 27	32 27 27
Rated wire cross-section, mm ² / AWG		4 / 22-10	4 / 22-10	4 / 22-10
Rated surge voltage kV / Contamination degree		8 / 3	8 / 3	8 / 3
Plug gauge acc. to EN 60 947-1 / Flamm. class acc. to UL 94		A3 / V-0	A3 / V-0	A3 / V-0
Connection data				
Single wire (solid) / stranded (flexible), mm ²		0.2-6 / -	0.2-6 / -	0.2-6 / -
Finely-stranded / finely-stranded (w/ferrules acc. to DIN 46228/1), mm ²		0.2-6 / 0.2-4	0.2-6 / 0.2-4	0.2-6 / 0.2-4
Clamping range, mm ²		0.2-6	0.2-6	0.2-6
Stripping length, mm		8	8	8
Torque, Nm / Screw spade connection, mm		0.5-1.0 / M 3	0.5-1.0 / M 3	0.5-1.0 / M 3
Features				
Material of insulated housing Temperature range		PA 6.6 / -40 °C to +120 °C	PA 6.6 / -40 °C to +120 °C	PA 6.6 / -40 °C to +120 °C
Number of cross-connection channels / Test pick-off option		- / 1	- / 2	- / 3
Accessories				
Quick marking PMC SB		PMC SB 7.5/40 WH	PMC SB 7.5/40 WH	PMC SB 7.5/40 WH
Cat. no.	Qty.	9326.7 400	9326.7 400	9326.7 400
Quick marking PMC SB, special print		PMC SB 7.5/40 So WH	PMC SB 7.5/40 So WH	PMC SB 7.5/40 So WH
Cat. no.	Qty.	3327.7 400	3327.7 400	3327.7 400
Screwdriver SDB		SDB 0.6 x 3.5	SDB 0.6 x 3.5	SDB 0.6 x 3.5
Cat. no.	Qty.	1086.0 1	1086.0 1	1086.0 1

TKS 4/1 F	TKS 4/2 F	TKS 4/3 F
		
		
Transformer terminal 1 screw connection / 1 spade connection Screw connection technology 27.7 x 7.5 x 33.1	Transformer terminal 2 screw connections / 2 spade connections Screw connection technology 27.7 x 7.5 x 33.1	Transformer terminal 3 screw connections / 3 spade connections Screw connection technology 27.7 x 7.5 x 33.1
TKS 4/1/F OG ● 50 1225.3	TKS 4/2/F OG ● 25 1226.3	TKS 4/3/F OG ● 20 1227.3
TKS 4/1/F GR ● 50 1225.6	TKS 4/2/F GR ● 25 1226.6	TKS 4/3/F GR ● 20 1227.6
IEC 800 UL 600 CSA 600 32 4/22-10 8/3 A3/V-0	IEC 800 UL 600 CSA 600 32 4/22-10 8/3 A3/V-0	IEC 800 UL 600 CSA 600 32 4/22-10 8/3 A3/V-0
0.2-6/- 0.2-6/0.2-4 0.2-6 8 0.5-1.0/M 3 6.3/2 x 2.8 x 0.8	0.2-6/- 0.2-6/0.2-4 0.2-6 8 0.5-1.0/M 3 6.3/2 x 2.8 x 0.8	0.2-6/- 0.2-6/0.2-4 0.2-6 8 0.5-1.0/M 3 6.3/2 x 2.8 x 0.8
PA 6.6 / -40 °C to +120 °C -/1	PA 6.6 / -40 °C to +120 °C -/2	PA 6.6 / -40 °C to +120 °C -/3
PMC SB 7.5/40 WH 9326.7 400	PMC SB 7.5/40 WH 9326.7 400	PMC SB 7.5/40 WH 9326.7 400
PMC SB 7.5/40 So WH 3327.7 400	PMC SB 7.5/40 So WH 3327.7 400	PMC SB 7.5/40 So WH 3327.7 400
SDB 0.6 x 3.5 1086.0 1	SDB 0.6 x 3.5 1086.0 1	SDB 0.6 x 3.5 1086.0 1

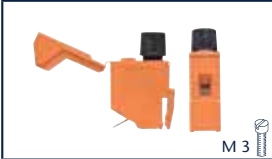

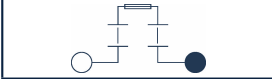
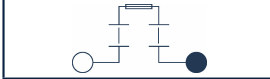
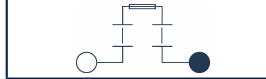

Transformer terminals TKS | Transformer-fused terminals TKS.. | SI

Screw connection system		TKS 10/1	TKS 10/2	TKS 10/3
<ul style="list-style-type: none"> Housing made of polyamide 6.6 UL 94 V-0 				
Connection diagram				
Description		Transformer terminal 1 screw connection	Transformer terminal 2 screw connections	Transformer terminal 3 screw connections
Wire connect type		Screw connection technology	Screw connection technology	Screw connection technology
Size (L x W x H), mm		37.5 x 11.25 x 39.5	37.5 x 22.55 x 39.5	37.5 x 33.75 x 33.75
Type / colour		TKS 10/1 OG ●	TKS 10/2 OG ●	TKS 10/3 OG ●
Cat. no.	Qty.	17032.3 50	17033.3 25	17046.3 20
Type / colour		TKS 10/1 GR ●	TKS 10/2 GR ●	TKS 10/3 GR ●
Cat. no.	Qty.	17032.6 50	17033.6 25	17046.6 20
Ratings		IEC UL CSA	IEC UL CSA	IEC UL CSA
Rated voltage (V)		800 600 600	800 600 600	800 600 600
Rated current (A)		57 50 50	57 65 65	57 65 65
Rated wire cross-section, mm ² / AWG		10 / 24-8	10 / 24-8	10 / 24-8
Rated surge voltage kV / Contamination degree		8 / 3	8 / 3	8 / 3
Plug gauge acc. to EN 60 947-1 / Flamm. class acc. to UL 94		B6 / V-0	B6 / V-0	B6 / V-0
Connection data				
Single wire (solid) / stranded (flexible), mm ²		0.2-16 / 0.2-16	0.2-16 / 0.2-16	0.2-16 / 0.2-16
Finely-stranded / finely-stranded (w/ferrules acc. to DIN 46228/1), mm ²		0.2-10 / 0.2-10	0.2-10 / 0.2-10	0.2-10 / 0.2-10
Clamping range, mm ²		0.2-16	0.2-16	0.2-16
Stripping length, mm		14	14	14
Torque, Nm / Screw		2.0 - 4.0 Slotted M 4	2.0 - 4.0 Slotted M 4	2.0 - 4.0 Slotted M 4
Fuse size				
Features				
Material of insulated housing Temperature range		PA 6.6 / -40 °C to +120 °C	PA 6.6 / -40 °C to +120 °C	PA 6.6 / -40 °C to +120 °C
Number of cross-connection channels / Test pick-off option				
Accessories				
Quick marking PMC SB, blank		PMC SB 7.5/40 WH	PMC SB 7.5/40 WH	PMC SB 7.5/40 WH
Cat. no.	Qty.	9326.7 400	9326.7 400	9326.7 400
Quick marking PMC SB, customer-specific, special print		PMC SB 7.5/40 So WH	PMC SB 7.5/40 So WH	PMC SB 7.5/40 So WH
Cat. no.	Qty.	3327.7 400	3327.7 400	3327.7 400
Screwdriver SDB		SDB 0.6 x 3.5	SDB 0.6 x 3.5	SDB 0.6 x 3.5
Cat. no.	Qty.	1086.0 1	1086.0 1	1086.0 1









TKS 16/2			TKS 4/SI 5 x 20			TKS 4/SI 5 x 25			TKS 4/SI 6.3 x 32		
											
											
Transformer terminal 2 screw connections			Transformer-fused terminal 1 screw connection			Transformer-fused terminal 1 screw connection			Transformer-fused terminal 1 screw connection		
Screw connection technology 44.4 x 26.25 x 48.1			Screw connection technology 28.3 x 12.5 x 43.9			Screw connection technology 28.3 x 12.5 x 43.9			Screw connection technology 28.3 x 12.5 x 49.4		
TKS 16/2 OG ●			TKS 4/SI 5 x 20 OG ●			TKS 4/SI 5 x 25 OG ●			TKS 4/SI 6.3 x 32 OG ●		
17193.3 25			17030.3 50			17047.3 50			17031.3 50		
TKS 16/2 GR ●			TKS 4/SI 5 x 20 GR ●			TKS 4/SI 5 x 25 GR ●			TKS 4/SI 6.3 x 32 GR ●		
17193.6 25			17030.6 50			17047.6 50			17031.6 50		
IEC	UL	cUL	IEC**	UL**	CSA**	IEC**	UL**	CSA**	IEC**	UL**	CSA**
1000	600	600	250	600	600	400	600	600	500	600	600
76	85	85	10**	10	10	10**	10	10	10**	10	10
16/6			4/24-10			4/24-10			4/24-10		
8/3			8/3			8/3			8/3		
A7/V-0			A4/V-0			A4/V-0			A4/V-0		
1.5-25/1.0-16			0.2-6/-			0.2-6/-			0.2-6/-		
1.0-16/1.0-16			0.2-6/0.2-4			0.2-6/0.2-4			0.2-6/0.2-4		
1.0-16			0.2-6			0.2-6			0.2-6		
14			8			8			8		
2.0-4.0 Slotted M 5			0.5-1.0 Slotted M 3 5 x 20			0.5-1.0 Slotted M 3 5 x 25			0.5-1.0 Slotted M 3 6.3 x 32		
PA 6.6 / -40 °C to +120 °C			PA 6.6 / -40 °C to +120 °C			PA 6.6 / -40 °C to +120 °C			PA 6.6 / -40 °C to +120 °C		
PMC SB 7.5/40 WH			PMC SB 7.5/40 WH			PMC SB 7.5/40 WH			PMC SB 7.5/40 WH		
9326.7 400			9326.7 400			9326.7 400			9326.7 400		
PMC SB 7.5/40 So WH			PMC SB 7.5/40 So WH			PMC SB 7.5/40 So WH			PMC SB 7.5/40 So WH		
3327.7 640			3327.7 400			3327.7 400			3327.7 400		
SDB 0.6 x 3.5			SDB 0.6 x 3.5			SDB 0.6 x 3.5			SDB 0.6 x 3.5		
1086.0 1			1086.0 1			1086.0 1			1086.0 1		

** = depending on the type of fuse in use.

Transformer terminals TKS | Transformer-fused terminals TKS.. | SI

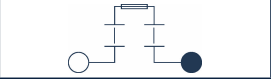
Screw connection system		TK 4	TK 4	TK 4
<ul style="list-style-type: none"> Housing made of polyamide 6.6 UL 94 V-0 				
Connection diagram				
Description		Transformer terminal 1 screw connection per pole	Transformer terminal 1 screw connection per pole	Transformer terminal 1 screw connection per pole
Wire connect type		Screw connection technology 20.5 x 7.5 x 33.1	Screw connection technology 20.5 x 7.5 x 33.1	Screw connection technology 20.5 x 7.5 x 33.1
Type / Colour	1-pole	TK 4/1 BG ●	TK 4/1 OG ●	TK 4/1 YE/GN ●
Cat. no.	Qty.	1141.2 50	1141.3 50	1136.8 50
Type / Colour	2-pole	TK 4/2 BG ●	TK 4/2 OG ●	
Cat. no.	Qty.	1142.2 25	1142.3 25	
Type / Colour	3-pole	TK 4/3 BG ●	TK 4/3 OG ●	
Cat. no.	Qty.	1143.2 20	1143.3 20	
Type / Colour	4-pole	TK 4/4 BG ●	TK 4/4 OG ●	
Cat. no.	Qty.	1144.2 15	1144.3 15	
Type / Colour	5-pole	TK 4/5 BG ●	TK 4/5 OG ●	
Cat. no.	Qty.	1145.2 10	1145.3 10	
Type / Colour	6-pole	TK 4/6 BG ●	TK 4/6 OG ●	
Cat. no.	Qty.	1146.2 10	1146.3 10	
Type / Colour	7-pole	TK 4/7 BG ●	TK 4/7 OG ●	
Cat. no.	Qty.	1147.2 10	1147.3 10	
Type / Colour	8-pole	TK 4/8 BG ●	TK 4/8 OG ●	
Cat. no.	Qty.	1148.2 5	1148.3 5	
Type / Colour	9-pole	TK 4/9 BG ●	TK 4/9 OG ●	
Cat. no.	Qty.	1149.2 5	1149.3 5	
Type / Colour	10-pole	TK 4/10 BG ●	TK 4/10 OG ●	
Cat. no.	Qty.	1150.2 5	1150.3 5	
Ratings		IEC CSAus CSA	IEC CSAus CSA	IEC CSAus CSA
Rated voltage (V)		800 600 600	800 600 600	800 600 600
Rated current (A)		32 30 30	32 30 30	32 30 30
Rated wire cross-section, mm ² / AWG		4/22-10	4/22-10	4/22-10
Rated surge voltage kV / Contamination degree		8/3	8/3	8/3
Plug gauge acc. to EN 60 947-1 / Flamm. class acc. to UL 94		A5/V-0	A5/V-0	A5/V-0
Connection data				
Single wire (solid) / stranded (flexible), mm ²		0.2-6/-	0.2-6/-	0.2-6/-
Finely-stranded / finely-stranded (w/ferrules acc. to DIN 46228/1), mm ²		0.2-6/0.2-4	0.2-6/0.2-4	0.2-6/0.2-4
Clamping range, mm ²		0.2-6	0.2-6	0.2-6
Stripping length, mm		9	9	9
Torque, Nm / Screw spade connection, mm		0.5-1.0	0.5-1.0	0.5-1.0
Features				
Material of insulated housing Temperature range		PA 6.6 / -40 °C to +120 °C	PA 6.6 / -40 °C to +120 °C	PA 6.6 / -40 °C to +120 °C
Number of cross-connection channels / Test pick-off option				
Accessories				
Quick marking PMC SB		PMC SB 7.5/40 WH	PMC SB 7.5/40 WH	PMC SB 7.5/40 WH
Cat. no.	Qty.	9326.7 400	9326.7 400	9326.7 400
Quick marking PMC SB, special print		PMC SB 7.5/40 So WH	PMC SB 7.5/40 So WH	PMC SB 7.5/40 So WH
Cat. no.	Qty.	3327.7 400	3327.7 400	3327.7 400
Screwdriver SDB		SDB 0.6 x 3.5	SDB 0.6 x 3.5	SDB 0.6 x 3.5
Cat. no.	Qty.	1086.0 1	1086.0 1	1086.0 1

Screw connection system

TK 4/SI			TK 4/SI			TK 4/F			TK 4/F			TK 10		
														
														
Transformer-fused terminal 1 screw connection per pole			Transformer-fused terminal 1 screw connection per pole			Transformer terminal 1 screw connection per pole / 1 spade connection			Transformer terminal 1 screw connection per pole / 1 spade connection			Transformer terminal 1 screw connection per pole		
Screw connection technology 20.5 x 15 x 37			Screw connection technology 20.5 x 15 x 37			Screw connection technology 27.8 x 7.5 x 33.1			Screw connection technology 20.5 x 7.5 x 33.1			Screw connection technology 40.5 x 9 + (ZP 6 mm) x 41		
TK 4/SI 5 x 20 BG ● 50 1139.2			TK 4/SI 5 x 20 OG ● 50 1139.3			TK 4/1/F BG ● 50 1151.2			TK 4/1/F OG ● 50 1151.3			TK 10 OG ● 50 1138.3		
TK 4/SI 5 x 25 BG ● 50 1140.2			TK 4/SI 5 x 25 OG ● 50 1140.3			TK 4/2/F BG ● 25 1152.2			TK 4/2/F OG ● 25 1152.3			TK 10/ZP* OG ● 50 1161.3		
						TK 4/3/F BG ● 20 1153.2			TK 4/3/F OG ● 20 1153.3			TK 10 BG ● 50 1138.2		
						TK 4/4/F BG ● 15 1154.2			TK 4/4/F OG ● 15 1154.3			TK 10/ZP* BG ● 50 1161.2		
						TK 4/5/F BG ● 10 1155.2			TK 4/5/F OG ● 10 1155.3					
						TK 4/6/F BG ● 10 1156.2			TK 4/6/F OG ● 10 1156.3					
						TK 4/7/F BG ● 10 1157.2			TK 4/7/F OG ● 10 1157.3					
						TK 4/8/F BG ● 5 1158.2			TK 4/8/F OG ● 5 1158.3					
						TK 4/9/F BG ● 5 1159.2			TK 4/9/F OG ● 5 1159.3					
						TK 4/10/F BG ● 5 1160.2			TK 4/10/F OG ● 5 1160.3			* With intermediate plate		
IEC	CSAus	CSA	IEC	CSAus	CSA	IEC	CSAus	CSA	IEC	CSAus	CSA	IEC	CSAus	CSA
250	300	300	250	300	300	800	600	600	800	600	600	800	600	600
10	10	10	10	10	10	32	30	30	32	30	30	57	65	65
4/22-10			4/22-10			4/22-10			4/22-10			10/22-10		
4/3			4/3			8/3			8/3			8/3		
A5/V-0			A5/V-0			A5/V-0			A5/V-0			A5/V-0		
0.2-6/-			0.2-6/-			0.2-6/-			0.2-6/-			0.2-10/-		
0.2-6/0.2-4			0.2-6/0.2-4			0.2-6/0.2-4			0.2-6/0.2-4			0.2-10/0.2-10		
0.2-6			0.2-6			0.2-6			0.2-6			0.2-10		
9			9			9			9			12		
0.5-1.0			0.5-1.0			0.5-1.0			0.5-1.0			1.2-2.0		
			6.3/2 x 2.8 x 0.8			6.3/2 x 2.8 x 0.8			6.3/2 x 2.8 x 0.8					
PA 6.6 / -40 °C to +120 °C			PA 6.6 / -40 °C to +120 °C			PA 6.6 / -40 °C to +120 °C			PA 6.6 / -40 °C to +120 °C			PA 6.6 / -40 °C to +120 °C		
PMC SB 7.5/40 WH 9326.7 400			PMC SB 7.5/40 WH 9326.7 400			PMC SB 7.5/40 WH 9326.7 400			PMC SB 7.5/40 WH 9326.7 400			PMC SB 7.5/40 WH 9326.7 400		
PMC SB 7.5/40 So WH 3327.7 400			PMC SB 7.5/40 So WH 3327.7 400			PMC SB 7.5/40 So WH 3327.7 400			PMC SB 7.5/40 So WH 3327.7 400			PMC SB 7.5/40 So WH 3327.7 400		
SDB 0.6 x 3.5 1086.0 1			SDB 0.6 x 3.5 1086.0 1			SDB 0.6 x 3.5 1086.0 1			SDB 0.6 x 3.5 1086.0 1			SDB 0.6 x 3.5 1086.0 1		

Here, competence is the order of the day: **Our screw connection system SRK/SSL**

CONTA-CLIP offers an innovative line of feed-through and protective-earth terminals featuring the proven screw-connection system for a wide range of cross-sectional widths ranging. The system is used worldwide and features a high degree of contact force and contact reliability.

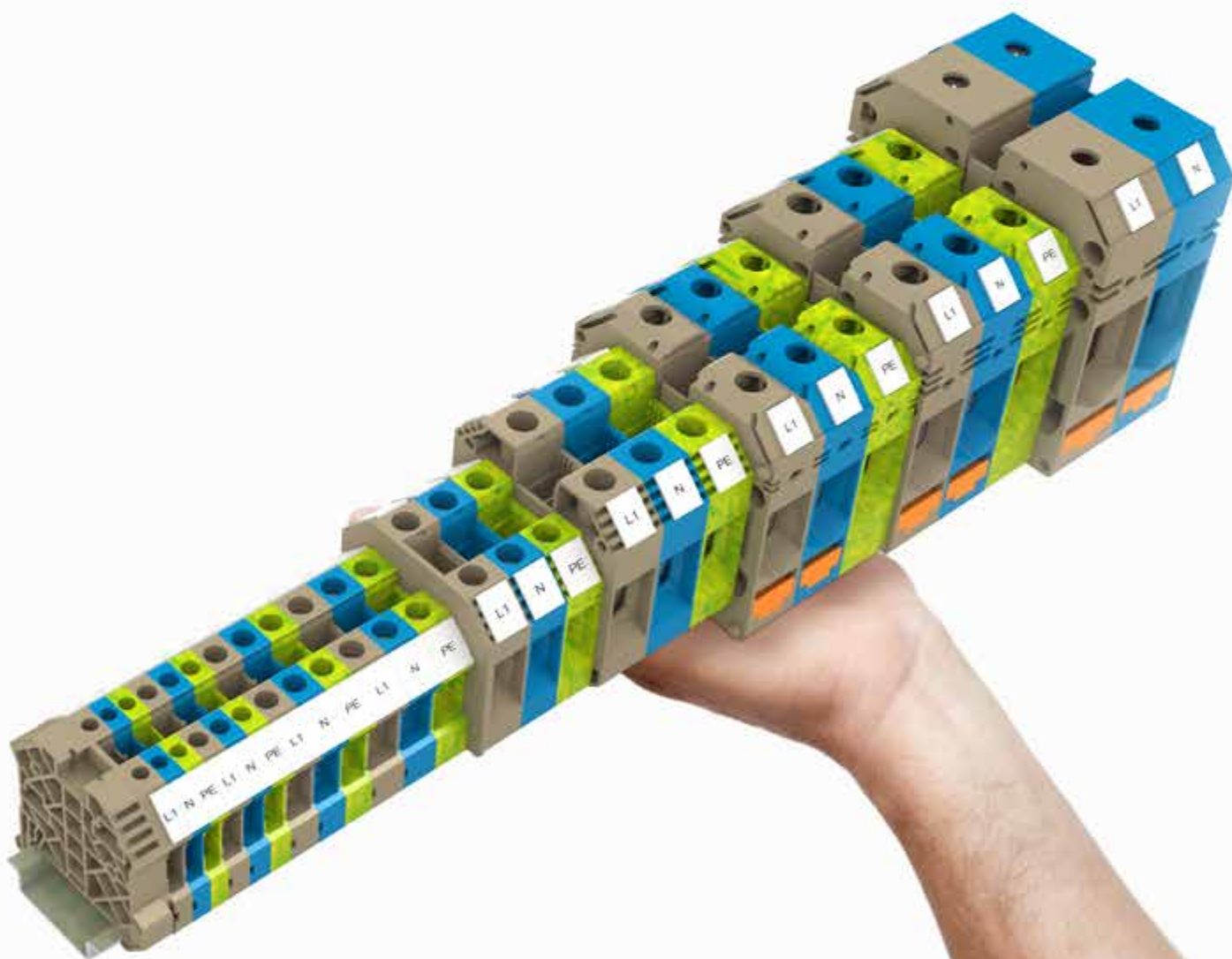

- **The screw-connection mechanism is easy to operate** and can be used to establish a quick, safe connection using solid and flexible wires with or without wire-end ferrules
- All protective-earth terminals feature a PE foot contact that is snapped on without screws (up to cross-sections of 35 mm²), **ensuring mechanical and electrical safety.**
- **Well-designed line of accessories** ensures a significant reduction in installation and storage costs
- The **SQI pluggable potential distribution system** can be used to multiply potential voltages horizontally

Proven screw connection system for safe and quick connection: **SRK/SSL**



Screw connection system

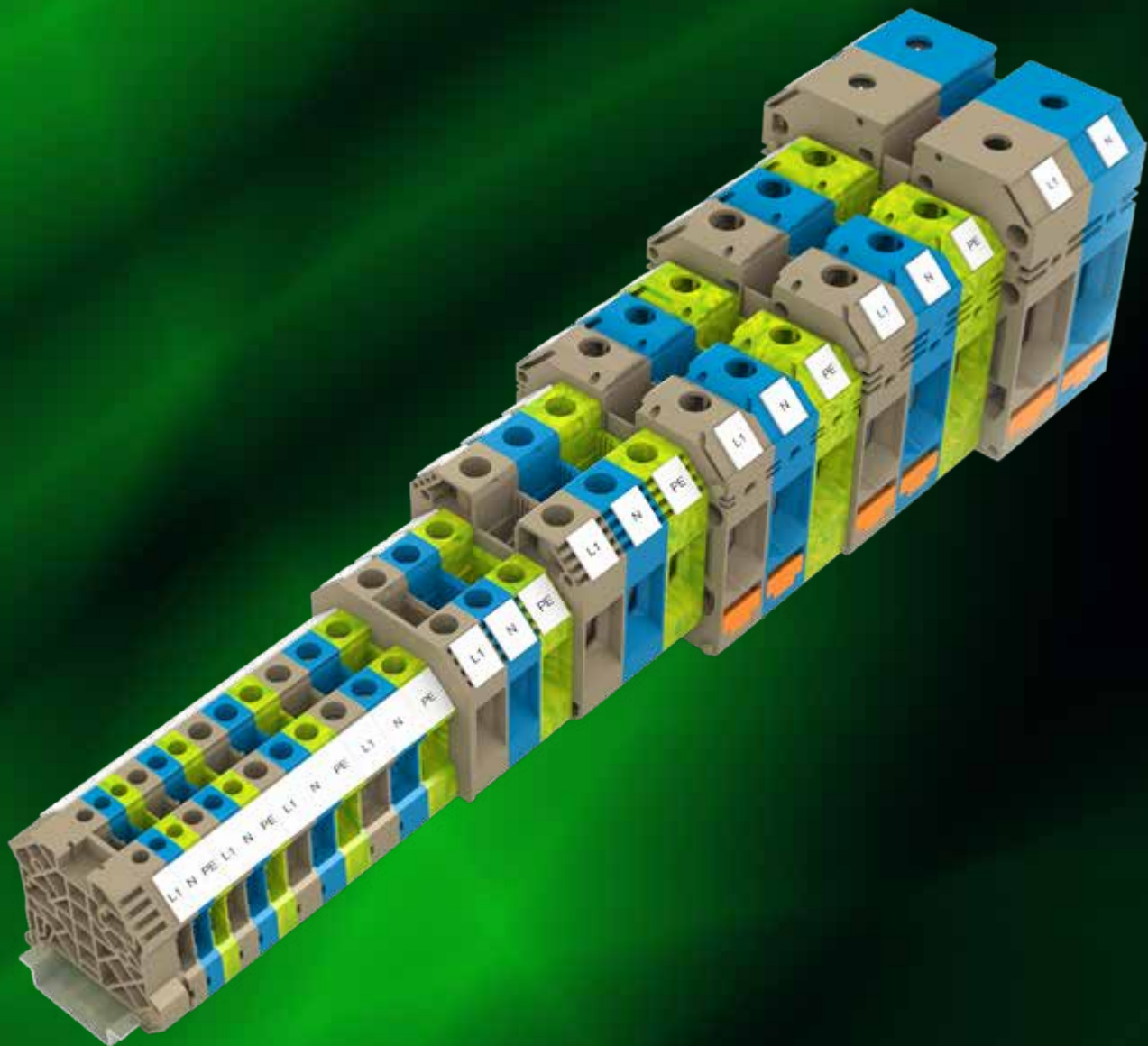

CONTA-CLIP offers an innovative line of feed-through and protective-earth terminals featuring the proven screw-connection system for cross-sections ranging all the way from 0.08 mm² to 120 mm². The screw-connection mechanism is easy to operate and can be used to establish a quick, safe connection using solid and flexible wires with or without wire-end ferrules. All protective-earth terminals feature a PE foot contact that is snapped on without screws (up to cross-sections of 35 mm²), ensuring mechanical and electrical safety.

Our well-designed line of accessories allows you to significantly reduce your installation and storage costs. The **SQI** pluggable potential distribution system can be used to multiply potential voltages horizontally. All of the insulating materials used in these product lines are free of pollutants. They also comply with flammability class V-0 (self-extinguishing) according to UL 94.

The advantages:

- Extended rated specifications
- Connection of multiple wires is possible
- Double cross-connection option up to 35 mm²
- Power feed with small cross-sections
- Option to cross-connect to functional terminals
- Additional connections from 4 to 120 mm²
- Comprehensive marking options

Features:

- Screw connection system
- Feed-through and PE terminals from 2.5 to 120 mm²
- Pluggable or screw-on cross-connection system
- High contact force and contact security
- Material: PA 6.6 UL 94 V-0
- PE foot contact on both sides

Listing of the concise features

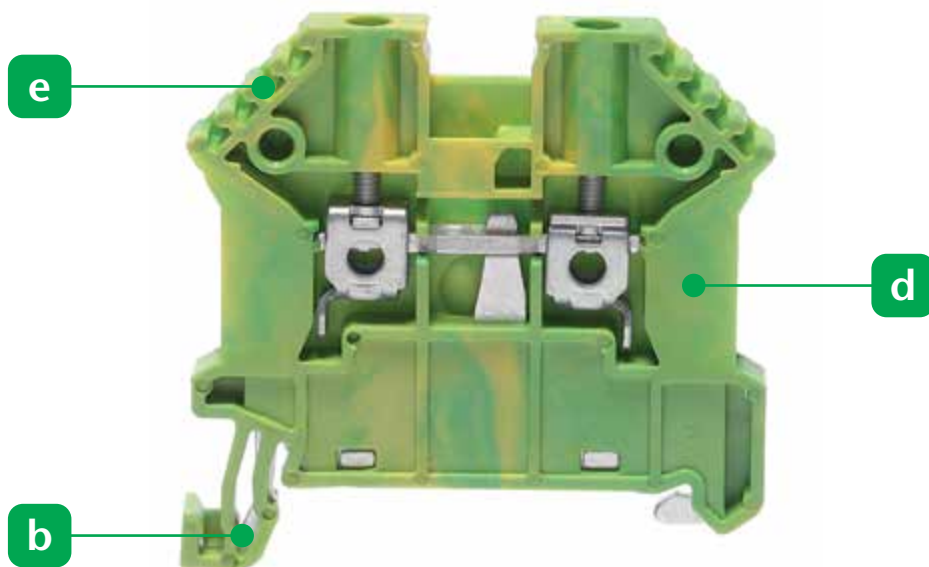
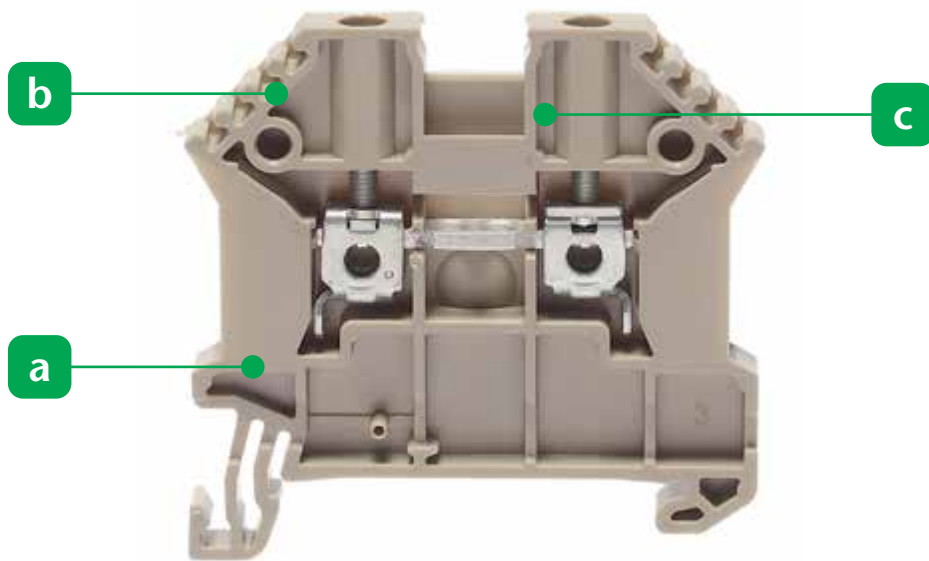

a The wire connection / contact reliability

The clamping yoke indirectly transmits pulling pressure from the screw and the clamping yoke against the busbar. The required contact force is generated by the torque applied to the screw.

- Rising clamp design
- High contact force and contact security / Minimal contact resistance
- There is a clear separation of electrical and mechanical functions.
- Clamping yoke made from hardened steel: galvanized, chrome-plated and additionally thick-film passivated
- The busbars are made from copper with surface coating (tin)
- Resistant to vibration and maintenance-free
- Corrosion-free
- Low voltage drop
- Compact design
- Foot base can be snapped on TS 35 DIN rail

b Easy and safe to wire with an established connection system

The screw-connection mechanism is easy to operate and can be used to establish a quick, safe connection using solid and flexible wires with or without wire-end ferrules.

- Simple and self-explanatory usage
- Can be used around the world
- A connection mechanism that has proven itself in billions of applications
- Generous wire-entry geometry
- Connection of multiple wires is possible
- PE foot contact on both sides – can be snapped on (no screws) to **TS 35 x 7.5** and **TS 35 x 15** rails.

c Pluggable cross-connection options

Distributing potentials with the pluggable **SQI** cross-connection system is quick and easy. Two cross-connection channels allow two voltages to be fed across when working with the standard terminals with rated cross-sections of 2.5 mm², 4 mm², 6 mm² and 10 mm².

- Available in 2 to 10 and 30 poles
- Simple to insert and thus quicker to install
- No insulation plate or partition plate is required between neighbouring cross-connections, since the **SQIs** have a touch-safe protective design.
- Cross-connection can carry the full rated current and voltage of the corresponding terminal block.
- Individual terminals can be skipped over by breaking out contact pins in the cross-connector

Feature

The **SRK 2.5 to SRK 10** feed-through terminals have a rail adapter built into the lower part of the terminal housing. This allows the cable shield from a control or data line to be connected in addition to the individual wires.

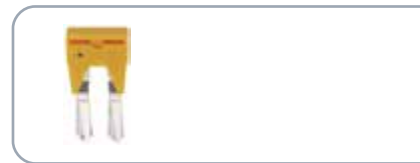

d Housing insulation material

- Polyamide PA6.6 UL 94, flamm. class V-0, self-extinguishing without burning drops
- Free of hazardous materials such as halogen or phosphor
- Creepage resistance: CTI 600
- Temperature resistant -40 °C to +120 °C

e Marking options

The standard terminals feature four labelling channels. They can be fitted with four **PMC SB** labelling tags or two **PMC BSTR** tags.

An overview of the advantages

Compact with identical shapes

The external geometry of the **SRK** feed-through terminals and **SSL** PE terminals is identical in contour in the cross-section range 2.5 mm², 4 mm², 6 mm² and 10 mm². Identical end plates and partition plates can thus be used. The width (pitch) for the terminal blocks is 2.5 mm² (5 mm), 4 mm² (6 mm), 6 mm² (8 mm) and 10 mm² (10 mm). Despite their small size, the **SRK** feed-through terminals have a rated voltage range of up to 1000 V.

Large wire-entry bay and connection space

The wire-entry bay is very spacious – this permits quick wiring of solid or flexible wires, with or without wire-end ferrules. The rated cross-sections specified in our documentation correspond to a connection with stranded wires using wire-end ferrules. It is also possible to use solid wires up to the next larger cross-section size.

Safety and stability

The insulated terminal housing with its special foot shape guarantees a convenient snap-on to the rail and a secure mount (on TS 35x7.5 and TS 35x15 according to EN 60715). Metal parts – including screws, clamping yoke, busbars, and PE foot – are securely mounted within the terminal housing. In addition, the screws are held captive from above by a screw brake mechanism. The PE terminals (**SSL 2.5 to SSL 35**) have a PE foot contact on both sides. It can be snapped on to rails (**TS 35 x 7.5 and TS 35 x 15**) with no need for screws and provides optimal mechanical and electrical safety.

Cross-connection system

The standard feed-through terminals from 2.5 mm² to 35 mm² feature two cross-connection channels. So the two-pole **SQI.../2** cross-connectors can be used to connect any number of terminals with each other.

Potential distribution

The **SQI** cross-connectors are available from 2 to 10 poles and with 30 poles. Two cross-connection channels allow two voltages to be fed across when working with the standard terminals with rated cross-sections of 2.5 mm², 4 mm², 6 mm² and 10 mm².. The **SQI** cross-connectors can be shortened using a cutting tool. The SQI system allows you to maintain touch-protection safety by covering the cut (uninsulated) end with a **SQIK** insulation cap.



Skip-over bridging

It is possible to skip over terminal blocks by breaking out individual contact poles. You can mark these contact elements using the plastic insulation of the cross-connector.



Power feed with small cross-sections

Screw terminals with larger cross-sections and standard cross-connectors can connect to a single terminal of the next size up for the power feed-in. The **SQI** cross-connection system can carry the rated voltage and rated current.



servicing work

The 30-pole cross-connector features a numbered scale which allows the user to easily count off the number of required poles.



Labelling







High-quality, quick and concise labelling is possible when using the **PMC SB, PMC BSTR or MC** labelling systems. The standard terminals feature up to four labelling channels.









A comprehensive line of accessories







- DIN rails
- Mechanical attachment / End stops
- Group marker holders
- End plates / Visual separation
- Cross-connections (potential distribution)
- Protective hoods







Feed-through terminals SRK | Protective earth terminals SSL

Screw connection system		SRK 2.5/2A	SRK 2.5/2A SAS	SSL 2.5/2A
<ul style="list-style-type: none"> Foot base can be snapped on TS 35 DIN rail Housing made of polyamide 6.6 UL 94 V-0 				
Connection diagram				
Description		Feed-through terminal 2 connections	Feed-through terminal 2 connections with shield connection rail	Protective earth terminal 2 connections
Wire connect type		Screw connection technology	Screw connection technology	Screw connection technology
Size (L x W x H) with TS35x7.5 mm		48 x 5 x 47	62.5 x 5 x 47	48 x 5 x 47
Type / colour		SRK 2.5/2A GN ●		SSL 2.5/2A GNYE ●
Cat. no.	Qty.	17100.1		17103.2
Type / colour		SRK 2.5/2A BG ●	SRK 2.5/2A SAS BG ●	
Cat. no.	Qty.	17100.2	17119.2	
Type / colour		SRK 2.5/2A OG ●		
Cat. no.	Qty.	17100.3		
Type / colour		SRK 2.5/2A BK ●		
Cat. no.	Qty.	17100.4		
Type / colour		SRK 2.5/2A BU ●		
Cat. no.	Qty.	17100.5		
Type / colour		SRK 2.5/2A GR ●		
Cat. no.	Qty.	17100.6		
Type / colour		SRK 2.5/2A WH ●		
Cat. no.	Qty.	17100.7		
Type / colour		SRK 2.5/2A YE ●		
Cat. no.	Qty.	17100.8		
Type / colour		SRK 2.5/2A RD ●		
Cat. no.	Qty.	17100.9		
Ratings		IEC	UL	CSA
Rated voltage (V)		1000	600	600
Rated current (A) Max. current capacity		24/32	25	25
Rated cross-section, mm ² / AWG		2.5 / 30-12	2.5 / 30-12	2.5 / 30-12
Rated surge voltage kV / Contamination degree		8 / 3	8 / 3	8 / 3
Plug gauge acc. to EN 60 947-1 / Flamm. class acc. to UL 94		A3 / V-0	A3 / V-0	A3 / V-0
Connection data				
Single wire (solid) / stranded (flexible), mm ²		0.2-4 / -	0.2-4 / -	0.2-4 / -
Finely-stranded / finely-stranded (w/ferrules acc. to DIN 46228/1), mm ²		0.2-4 / 0.2-2.5	0.2-4 / 0.2-2.5	0.2-4 / 0.2-2.5
Clamping range, mm ²		0.2-4	0.2-4	0.2-4
Stripping length, mm		10	10	10
Torque, Nm / Screw		0.4 - 0.8 Slotted M 2.5	0.4 - 0.8 Slotted M 2.5	0.4 - 0.8 Slotted M 2.5
Special connection, mm			Faston 2.8	
Features				
Material of insulated housing Temperature range		PA 6.6 / -40°C to +120 °C	PA 6.6 / -40 °C to +120 °C	PA 6.6 / -40 °C to +120 °C
Number of cross-connection channels / Test pick-off option		2 / 1	2 / 1	1 / 1
Accessories				
End plate AP		AP 2.5-10 BG	AP 2.5-10 BG	AP 2.5-10 BG
Cat. no.	Qty.	2001.2	2001.2	2001.2
Pick-off terminal SMAG				
Cat. no.	Qty.			
Partition plate TW		TW 2.5-10 BG	TW 2.5-10 BG	TW 2.5-10 BG
Cat. no.	Qty.	2002.2	2002.2	2002.2
Insulating cap SQIK for cross-connector		SQIK 2.5-10 YE	SQIK 2.5-10 YE	SQIK 2.5-10 YE
Cat. no.	Qty.	17200.8	17200.8	17200.8
Insulated cross-connection SQI		SQI 2.5/2 YE	SQI 2.5/2 YE	SQI 2.5/2 YE
Cat. no.	Qty.	17201.8	17201.8	17201.8
Insulated cross-connection SQI		SQI 2.5/3 YE	SQI 2.5/3 YE	SQI 2.5/3 YE
Cat. no.	Qty.	17202.8	17202.8	17202.8
Insulated cross-connection SQI		SQI 2.5/4 YE	SQI 2.5/4 YE	SQI 2.5/4 YE
Cat. no.	Qty.	17203.8	17203.8	17203.8
Insulated cross-connection SQI		SQI 2.5/5 YE	SQI 2.5/5 YE	SQI 2.5/5 YE
Cat. no.	Qty.	17204.8	17204.8	17204.8
Insulated cross-connection SQI		SQI 2.5/6 YE	SQI 2.5/6 YE	SQI 2.5/6 YE
Cat. no.	Qty.	17205.8	17205.8	17205.8
Insulated cross-connection SQI		SQI 2.5/7 YE	SQI 2.5/7 YE	SQI 2.5/7 YE
Cat. no.	Qty.	17206.8	17206.8	17206.8
Insulated cross-connection SQI		SQI 2.5/8 YE	SQI 2.5/8 YE	SQI 2.5/8 YE
Cat. no.	Qty.	17207.8	17207.8	17207.8
Insulated cross-connection SQI		SQI 2.5/9 YE	SQI 2.5/9 YE	SQI 2.5/9 YE
Cat. no.	Qty.	17208.8	17208.8	17208.8
Insulated cross-connection SQI		SQI 2.5/10 YE	SQI 2.5/10 YE	SQI 2.5/10 YE
Cat. no.	Qty.	17209.8	17209.8	17209.8
Insulated cross-connection SQI		SQI 2.5/30 YE	SQI 2.5/30 YE	SQI 2.5/30 YE
Cat. no.	Qty.	17210.8	17210.8	17210.8
End stop SES		SES 35 BG	SES 35 BG	SES 35 BG
Cat. no.	Qty.	17250.2	17250.2	17250.2
Screwdriver SDB		SDB 0.5 x 3.0	SDB 0.5 x 3.0	SDB 0.5 x 3.0
Cat. no.	Qty.	1085.0	1085.0	1085.0
Quick marking PMC SB		PMC SB 5/50 WH	PMC SB 5/50 WH	PMC SB 5/50 WH
Cat. no.	Qty.	4600.7	4600.7	4600.7







SRK 4/2A	SRK 4/2A SAS	SSL 4/2A
		
		
Feed-through terminal 2 connections	Feed-through terminal 2 connections with shield connection rail	Protective earth terminal 2 connections
Screw connection technology 48 x 6 x 47	Screw connection technology 62.5 x 5 x 47	Screw connection technology 48 x 5 x 47
SRK 4/2A GN ●		SSL 4/2A GNYE ●
17104.1 100		17107.2 100
SRK 4/2A BG ●	SRK 4/2A SAS BG ●	
17104.2 100	17116.2 80	
SRK 4/2A OG ●		
17104.3 100		
SRK 4/2A BK ●		
17104.4 100		
SRK 4/2A BU ●		
17104.5 100		
SRK 4/2A GR ●		
17104.6 100		
SRK 4/2A WH ●		
17104.7 100		
SRK 4/2A YE ●		
17104.8 100		
SRK 4/2A RD ●		
17104.9 100		
IEC UL CSA	IEC	IEC UL CSA
1000 600 600	400	
32/41 35 35	32/41	
4/26-10	4/26-10	4/26-10
8/3	8/3	8/3
A4/V-0	A4/V-0	A4/V-0
0.2-6/-	0.2-6/-	0.2-6/-
0.2-6/0.2-4	0.2-6/0.2-4	0.2-6/0.2-4
0.2-6	0.2-6	0.2-6
10	10	10
0.5 - 1.0 Slotted M 3	0.5 - 1.0 Slotted M 3 Faston 2.8	0.5 - 1.0 Slotted M 3
PA 6.6 / -40 °C to +120 °C	PA 6.6 / -40 °C to +120 °C	PA 6.6 / -40 °C to +120 °C
2/1	2/1	1/1
AP 2.5-10 BG	AP 2.5-10 BG	AP 2.5-10 BG
2001.2 50	2001.2 50	2001.2 50
SMAG 4/2.5 BG	SMAG 4/2.5 BG	SMAG 4/2.5 BG
17120.2 10	17120.2 10	17120.2 10
TW 2.5-10 BG	TW 2.5-10 BG	TW 2.5-10 BG
2002.2 50	2002.2 50	2002.2 50
SQIK 2.5-10 YE	SQIK 2.5-10 YE	SQIK 2.5-10 YE
17200.8 20	17200.8 20	17200.8 20
SQI 4/2 YE	SQI 4/2 YE	SQI 4/2 YE
17211.8 50	17211.8 50	17211.8 50
SQI 4/3 YE	SQI 4/3 YE	SQI 4/3 YE
17212.8 50	17212.8 50	17212.8 50
SQI 4/4 YE	SQI 4/4 YE	SQI 4/4 YE
17213.8 20	17213.8 20	17213.8 20
SQI 4/5 YE	SQI 4/5 YE	SQI 4/5 YE
17214.8 20	17214.8 20	17214.8 20
SQI 4/6 YE	SQI 4/6 YE	SQI 4/6 YE
17215.8 20	17215.8 20	17215.8 20
SQI 4/7 YE	SQI 4/7 YE	SQI 4/7 YE
17216.8 20	17216.8 20	17216.8 20
SQI 4/8 YE	SQI 4/8 YE	SQI 4/8 YE
17217.8 10	17217.8 10	17217.8 10
SQI 4/9 YE	SQI 4/9 YE	SQI 4/9 YE
17218.8 10	17218.8 10	17218.8 10
SQI 4/10 YE	SQI 4/10 YE	SQI 4/10 YE
17219.8 10	17219.8 10	17219.8 10
SQI 4/30 YE	SQI 4/30 YE	SQI 4/30 YE
17220.8 5	17220.8 5	17220.8 5
SES 35 BG	SES 35 BG	SES 35 BG
17250.2 50	17250.2 50	17250.2 50
SDB 0.6 x 3.5	SDB 0.6 x 3.5	SDB 0.6 x 3.5
1086.0 1	1086.0 1	1086.0 1
PMC SB 6/50 WH	PMC SB 6/50 WH	PMC SB 6/50 WH
4702.7 500	4702.7 500	4702.7 500

Feed-through terminals SRK | Protective earth terminals SSL

Screw connection system		SRK 6/2A	SRK 6/2A SAS	SSL 6/2A
<ul style="list-style-type: none"> Foot base can be snapped on TS 35 DIN rail Housing made of polyamide 6.6 UL 94 V-0 				
Connection diagram				
Description		Feed-through terminal 2 connections	Feed-through terminal 2 connections with shield connection rail	Protective earth terminal 2 connections
Wire connect type		Screw connection technology	Screw connection technology	Screw connection technology
Size (L x W x H) with TS35 x 7.5 mm		48 x 8 x 47	62.5 x 8 x 47	48 x 8 x 47
Type / colour		SRK 6/2A GN ●		SSL 6/2A GN YE ●
Cat. no.	Qty.	17108.1 100		17111.2 100
Type / colour		SRK 6/2A BG ●	SRK 6/2A SAS BG ●	
Cat. no.	Qty.	17108.2 100	17117.2 80	
Type / colour		SRK 6/2A OG ●		
Cat. no.	Qty.	17108.3 100		
Type / colour		SRK 6/2A BK ●		
Cat. no.	Qty.	17108.4 100		
Type / colour		SRK 6/2A BU ●		
Cat. no.	Qty.	17108.5 100		
Type / colour		SRK 6/2A GR ●		
Cat. no.	Qty.	17108.6 100		
Type / colour		SRK 6/2A WH ●		
Cat. no.	Qty.	17108.7 100		
Type / colour		SRK 6/2A YE ●		
Cat. no.	Qty.	17108.8 100		
Type / colour		SRK 6/2A RD ●		
Cat. no.	Qty.	17108.9 100		
Ratings		IEC UL CSA	IEC	IEC UL CSA
Rated voltage (V)		1000 600 600	320	
Rated current (A) Max. current capacity		41/57 50 50	41/57	
Rated cross-section, mm ² / AWG		10 / 22–8	10 / 22–8	10 / 22–8
Rated surge voltage kV / Contamination degree		8 / 3	8 / 3	8 / 3
Plug gauge acc. to EN 60 947-1 / Flamm. class acc. to UL 94		A5 / V-0	A5 / V-0	A5 / V-0
Connection data				
Single wire (solid) / stranded (flexible), mm ²		0.2–10 / 0.2–10	0.2–10 / 0.2–10	0.2–10 / 0.2–10
Finely-stranded / finely-stranded (w/ferrules acc. to DIN 46228/1), mm ²		0.2–10 / 0.2–6	0.2–10 / 0.2–6	0.2–10 / 0.2–6
Clamping range, mm ²		0.2–10	0.2–10	0.2–10
Stripping length, mm		10	10	10
Torque, Nm / Screw		1.2–2.0 Slotted M 3.5	1.2–2.0 Slotted M 3.5	1.2–2.0 Slotted M 3.5
Special connection, mm			Faston 2.8	
Features				
Material of insulated housing Temperature range		PA 6.6 / -40 °C to +120 °C	PA 6.6 / -40 °C to +120 °C	PA 6.6 / -40 °C to +120 °C
Number of cross-connection channels / Test pick-off option		2 / 1	2 / 1	1 / 1
Accessories				
End plate AP		AP 2.5–10 BG	AP 2.5–10 BG	AP 2.5–10 GN
Cat. no.	Qty.	2001.2 50	2001.2 50	2001.1 50
Pick-off terminal SMAG		SMAG 6/4 BG	SMAG 6/4 BG	SMAG 6/4 BG
Cat. no.	Qty.	17121.2 10	17121.2 10	17121.2 10
Partition plate TW		TW 2.5–10 BG	TW 2.5–10 BG	TW 2.5–10 BG
Cat. no.	Qty.	2002.2 50	2002.2 50	2002.2 50
Insulating cap SQIK for cross-connector		SQIK 2.5–10 YE	SQIK 2.5–10 YE	SQIK 2.5–10 YE
Cat. no.	Qty.	17200.8 20	17200.8 20	17200.8 20
Insulated cross-connection SQI		SQI 6/2 YE	SQI 6/2 YE	SQI 6/2 YE
Cat. no.	Qty.	17221.8 50	17221.8 50	17221.8 50
Insulated cross-connection SQI		SQI 6/3 YE	SQI 6/3 YE	SQI 6/3 YE
Cat. no.	Qty.	17222.8 50	17222.8 50	17222.8 50
Insulated cross-connection SQI		SQI 6/4 YE	SQI 6/4 YE	SQI 6/4 YE
Cat. no.	Qty.	17223.8 20	17223.8 20	17223.8 20
Insulated cross-connection SQI		SQI 6/5 YE	SQI 6/5 YE	SQI 6/5 YE
Cat. no.	Qty.	17224.8 20	17224.8 20	17224.8 20
Insulated cross-connection SQI		SQI 6/6 YE	SQI 6/6 YE	SQI 6/6 YE
Cat. no.	Qty.	17225.8 20	17225.8 20	17225.8 20
Insulated cross-connection SQI		SQI 6/7 YE	SQI 6/7 YE	SQI 6/7 YE
Cat. no.	Qty.	17226.8 20	17226.8 20	17226.8 20
Insulated cross-connection SQI		SQI 6/8 YE	SQI 6/8 YE	SQI 6/8 YE
Cat. no.	Qty.	17227.8 10	17227.8 10	17227.8 10
Insulated cross-connection SQI		SQI 6/9 YE	SQI 6/9 YE	SQI 6/9 YE
Cat. no.	Qty.	17228.8 10	17228.8 10	17228.8 10
Insulated cross-connection SQI		SQI 6/10 YE	SQI 6/10 YE	SQI 6/10 YE
Cat. no.	Qty.	17229.8 10	17229.8 10	17229.8 10
Insulated cross-connection SQI		SQI 6/30 YE	SQI 6/30 YE	SQI 6/30 YE
Cat. no.	Qty.	17230.8 5	17230.8 5	17230.8 5
End stop SES		SES 35 BG	SES 35 BG	SES 35 BG
Cat. no.	Qty.	17250.2 50	17250.2 50	17250.2 50
Screwdriver SDB		SDB 0.6 x 3.5	SDB 0.6 x 3.5	SDB 0.6 x 3.5
Cat. no.	Qty.	1086.0 1	1086.0 1	1086.0 1
Quick marking PMC SB		PMC SB 8/40 WH	PMC SB 8/40 WH	PMC SB 8/40 WH
Cat. no.	Qty.	9323.7 400	9323.7 400	9323.7 400











SRK 10/2A	SRK 10/2A SAS	SSL 10/2A
		
		
Feed-through terminal 2 connections	Feed-through terminal 2 connections with shield connection rail	Protective earth terminal 2 connections
Screw connection technology 48 x 10 x 47	Screw connection technology 62.5 x 10 x 47	Screw connection technology 48 x 10 x 47
SRK 10/2A GN ●		SSL 10/2A GNYE ●
17112.1 100		17115.2 100
SRK 10/2A BG ●	SRK 10/2A SAS BG ●	
17112.2 100	17118.2 80	
SRK 10/2A OG ●		
17112.3 100		
SRK 10/2A BK ●		
17112.4 100		
SRK 10/2A BU ●		
17112.5 100		
SRK 10/2A GR ●		
17112.6 100		
SRK 10/2A WH ●		
17112.7 100		
SRK 10/2A YE ●		
17112.8 100		
SRK 10/2A RD ●		
17112.9 100		
IEC UL CSA	IEC	IEC UL CSA
1000 600 600	250	
57/76 65 65	57/76	
16/18-6	16/18-6	16/18-6
8/3	8/3	8/3
B7/V-0	B7/V-0	B7/V-0
0.2-16/0.2-16	0.2-16/0.2-16	0.2-16/0.2-16
0.2-16/0.2-10	0.2-16/0.2-10	0.2-16/0.2-10
0.6-16	0.6-16	0.6-16
10	10	10
1.2 - 2.4 Slotted M 4	1.2 - 2.4 Slotted M 4 Faston 2.8	1.2 - 2.4 Slotted M 4
PA 6.6 / -40 °C to +120 °C	PA 6.6 / -40 °C to +120 °C	PA 6.6 / -40 °C to +120 °C
2/1	2/1	1/1
AP 2.5-10 BG	AP 2.5-10 BG	AP 2.5-10 GN
2001.2 50	2001.2 50	2001.1 50
SMAG 10/6 BG	SMAG 10/6 BG	SMAG 10/6 BG
17122.2 10	17122.2 10	17122.2 10
TW 2.5-10 BG	TW 2.5-10 BG	TW 2.5-10 BG
2002.2 50	2002.2 50	2002.2 50
SQIK 2.5-10 YE	SQIK 2.5-10 YE	SQIK 2.5-10 YE
17200.8 20	17200.8 20	17200.8 20
SQI 10/2 YE	SQI 10/2 YE	SQI 10/2 YE
17231.8 50	17231.8 50	17231.8 50
SQI 10/3 YE	SQI 10/3 YE	SQI 10/3 YE
17232.8 50	17232.8 50	17232.8 50
SQI 10/4 YE	SQI 10/4 YE	SQI 10/4 YE
17233.8 20	17233.8 20	17233.8 20
SQI 10/5 YE	SQI 10/5 YE	SQI 10/5 YE
17234.8 20	17234.8 20	17234.8 20
SQI 10/6 YE	SQI 10/6 YE	SQI 10/6 YE
17235.8 20	17235.8 20	17235.8 20
SQI 10/7 YE	SQI 10/7 YE	SQI 10/7 YE
17236.8 20	17236.8 20	17236.8 20
SQI 10/8 YE	SQI 10/8 YE	SQI 10/8 YE
17237.8 10	17237.8 10	17237.8 10
SQI 10/9 YE	SQI 10/9 YE	SQI 10/9 YE
17238.8 10	17238.8 10	17238.8 10
SQI 10/10 YE	SQI 10/10 YE	SQI 10/10 YE
17239.8 10	17239.8 10	17239.8 10
SQI 10/30 YE	SQI 10/30 YE	SQI 10/30 YE
17240.8 5	17240.8 5	17240.8 5
SES 35 BG	SES 35 BG	SES 35 BG
17250.2 50	17250.2 50	17250.2 50
SDB 0.8 x 4.0	SDB 0.8 x 4.0	SDB 0.8 x 4.0
1087.0 1	1087.0 1	1087.0 1
PMC SB 8/40 WH	PMC SB 8/40 WH	PMC SB 8/40 WH
9323.7 400	9323.7 400	9323.7 400







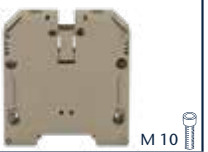

Feed-through terminals SRK | Protective earth terminals SSL

Screw connection system		SRK 16/2A	SSL 16/2A	SRK 16/2A/IS
<ul style="list-style-type: none"> Foot base can be snapped on TS 35 DIN rail Housing made of polyamide 6.6 UL 94 V-0 				
Connection diagram				
Description		Feed-through terminal 2 connections	Protective earth terminal 2 connections	Feed-through terminal 2 connections
Wire connect type		Screw connection technology	Screw connection technology	Screw connection technology
Size (L x W x H) with TS35x7.5 mm		53 x 12.1 x 55	53 x 12.1 x 55	53 x 12.1 x 55
Type / colour		SRK 16/2A BG ●	SSL 16/2A GNYE ●●	SRK 16/2A/IS BG ●
Cat. no.	Qty.	17124.2 50	17130.2 50	17126.2 50
Type / colour		SRK 16/2A BU ●		SRK 16/2A/IS BU ●
Cat. no.	Qty.	17124.5 50		17126.5 50
Type / colour		SRK 16/2A/Z BG ●		SRK 16/2A/Z/IS BG ●
Cat. no.	Qty.	17125.2 50		17127.2 50
Ratings		IEC UL CSA	IEC UL CSA	IEC UL CSA
Rated voltage (V)		1000 600 600		1000 600 600
Rated current (A)		76/101 80 80		76/101 80 80
Rated wire cross-section, mm ² / AWG		16/16-4	16/16-4	16/16-4
Rated surge voltage kV / Contamination degree		8/3	8/3	8/3
Plug gauge acc. to EN 60 947-1 / Flamm. class acc. to UL 94		A7/V-0	A7/V-0	A7/V-0
Connection data				
Single wire (solid) / stranded (flexible), mm ²		1.5-25 / 1.5-25	1.5-25 / 1.5-25	1.5-25 / 1.5-25
Finely-stranded / finely-stranded (w/ferrules acc. to DIN 46228/1), mm ²		1.5-25 / 1-16	1.5-25 / 1-16	1.5-25 / 1-16
Clamping range, mm ²		1.5-25	1.5-25	1.5-25
Stripping length, mm		14	14	14
Torque, Nm / Screw		2.5 - 3 Slotted M 5	2.5 - 3 Slotted M 5	2.5 - 3 Hexagon socket M 5
Features				
Material of insulated housing Temperature range		PA 6.6 / -40 °C to +120 °C	PA 6.6 / -40 °C to +120 °C	PA 6.6 / -40 °C to +120 °C
Number of cross-connection channels / Test pick-off option		2/1	1/1	1/2
Accessories				
End plate AP		SAP 16/2A BG	SAP 16/2A GN	SAP 16/2A BG
Cat. no.	Qty.	17254.2 20	17254.1 20	17254.2 20
Insulated cross-connection SQI		SQI 16/2 YE	SQI 16/2 YE	SQI 16/2 YE
Cat. no.	Qty.	17247.8 20	17247.8 20	17247.8 20
Cover		SAD 1/12/B WH	SAD 1/12/B WH	SAD 1/12/B WH
Cat. no.	Qty.	17248.7 20	17248.7 20	17248.7 20
Cover		SAD 1/12/B YE	SAD 1/12/B YE	SAD 1/12/B YE
Cat. no.	Qty.	17249.8 20	17249.8 20	17249.8 20
Pick-off terminal		SMAG 16/6 BG	SMAG 16/6 BG	SMAG 16/6 BG
Cat. no.	Qty.	17135.2 10	17135.2 10	17135.2 10
Screwdriver SBD		SDB 0.8 x 4.0	SDB 0.8 x 4.0	
Cat. no.	Qty.	1087.0 1	1087.0 1	
End stop SES		SES 35 BG	SES 35 BG	SES 35 BG
Cat. no.	Qty.	17250.2 50	17250.2 50	17250.2 50
Allen key socket wrench ISKS				
Cat. no.	Qty.			
Quick marking PMC SB		PMC SB 8/40 WH	PMC SB 8/40 WH	PMC SB 8/40 WH
Cat. no.	Qty.	9323.7 400	9323.7 400	9323.7 400

SSL 16/2A/IS			SRK 35/2A			SSL 35/2A			SRK 35/2A/IS			SSL 35/2A/IS		
														
														
Protective earth terminal 2 connections			Feed-through terminal 2 connections			Protective earth terminal 2 connections			Feed-through terminal 2 connections			Protective earth terminal 2 connections		
Screw connection technology 53 x 12.1 x 55			Screw connection technology 59 x 16.1 x 65.5			Screw connection technology 59 x 16.1 x 65.5			Screw connection technology 59 x 16.1 x 65.5			Screw connection technology 59 x 16.1 x 65.5		
SSL 16/2A/IS GNYE  50			SRK 35/2A BG  20			SSL 35/2A GNYE  20			SRK 35/2A/IS BG  20			SSL 35/2A/IS GNYE  20		
17131.2			17140.2			17145.2			17142.2			17147.2		
			SRK 35/2A BU  20						SRK 35/2A/IS BU  20					
			17140.5						17142.5					
			SRK 35/2A/Z BG  20						SRK 35/2A/Z/IS BG  20					
			17141.2						17143.2					
IEC	UL	CSA	IEC	UL	CSA	IEC	UL	CSA	IEC	UL	CSA	IEC	UL	CSA
			1000	600	600				1000	600	600			
			125/150	150	150				125/150	150	150			
			35/16-1/0			35/16-1/0			35/16-1/0			35/16-1/0		
			8/3			8/3			8/3			8/3		
			B9/V-0			B9/V-0			B9/V-0			B9/V-0		
			1.5-25/1.5-25			1.5-50/1.5-50			1.5-50/1.5-50			1.5-50/1.5-50		
			1.5-25/1-16			1.5-50/1-35			1.5-50/1-35			1.5-50/1-35		
			1.5-25			1.5-50			1.5-50			1.5-50		
			14			18			18			18		
			2.5-3 Hexagon socket M 5			3.2-3.7 Slotted M 6			3.2-3.7 Hexagon socket M 6			3.2-3.7 Hexagon socket M 6		
			PA 6.6 / -40 °C to +120 °C			PA 6.6 / -40 °C to +120 °C			PA 6.6 / -40 °C to +120 °C			PA 6.6 / -40 °C to +120 °C		
			1/1			2/1			2/1			1/1		
			SAP 16/2A GN											
			17254.1											
			20											
			SQI 16/2 YE			SQI 35/2 YE			SQI 35/2 YE			SQI 35/2 YE		
			17247.8			17252.8			17252.8			17252.8		
			20			20			20			20		
			SAD 1/12/B WH			SAD 1/16/B WH			SAD 1/16/B WH			SAD 1/16/B WH		
			17248.7			17282.7			17282.7			17282.7		
			20			20			20			20		
			SAD 1/12/B YE			SAD 1/16/B YE			SAD 1/16/B YE			SAD 1/16/B YE		
			17249.8			17281.8			17281.8			17281.8		
			20			20			20			20		
			SMAG 16/6 BG			SMAG 35/6 BG			SMAG 35/6 BG			SMAG 35/6 BG		
			17135.2			17148.2			17148.2			17148.2		
			10			10			10			10		
						SDB 1.2 x 6.5			SDB 1.2 x 6.5					
						1088.0			1088.0					
						1			1					
			SES 35 BG			SES 35 BG			SES 35 BG			SES 35 BG		
			17250.2			17250.2			17250.2			17250.2		
			50			50			50			50		
									ISKS 5			ISKS 5		
									2818.0			2818.0		
									1			1		
			PMC SB 8/40 WH			PMC SB 8/40 WH			PMC SB 8/40 WH			PMC SB 8/40 WH		
			9323.7			9323.7			9323.7			9323.7		
			400			400			400			400		

Feed-through terminals SRK | Protective earth terminals SSL

Screw connection system		SRK 50/2A	SSL 50/2A	SRK 70/2A
<ul style="list-style-type: none"> Foot base can be snapped on TS 35 DIN rail Housing made of polyamide 6.6 UL 94 V-0 				
Connection diagram				
Description		Feed-through terminal 2 connections	Protective earth terminal 2 connections	Feed-through terminal 2 connections
Wire connect type		Screw connection technology	Screw connection technology	Screw connection technology
Size (L x W x H), mm		72.5 x 18.5 x 72.5	72.5 x 18.5 x 72.5	76.5 x 20.5 x 82
Size (L x W x H) with TS35x7.5 mm		72.5 x 18.5 x 74	72.5 x 18.5 x 74	76.5 x 20.5 x 84
Type / colour		SRK 50/2A BG 	SSL 50/2A GNYE 	SRK 70/2A BG 
Cat. no.	Qty.	17156.2 10	17158.2 10	17161.2 10
Type / colour		SRK 50/2A BU 		SRK 70/2A BU 
Cat. no.	Qty.	17156.5 10		17161.5 10
Ratings		IEC UL CSA	IEC UL CSA	IEC UL CSA
Rated voltage (V)		1000 600 600		1000 600 600
Rated current (A)		150/192 150 150		192/232 205 205
Rated wire cross-section, mm ² / AWG		50/8-0	50/8-0	70/6-000
Rated surge voltage kV / Contamination degree		8/3	8/3	8/3
Plug gauge acc. to EN 60 947-1 / Flamm. class acc. to UL 94		B10/V-0	B10/V-0	B11/V-0
Connection data				
Single wire (solid) / stranded (flexible), mm ²		10-70/10-70	10-70/10-70	10-95/10-95
Finely-stranded / finely-stranded (w/ferrules acc. to DIN 46228/1), mm ²		10-50/10-50	10-50/10-50	10-70/10-70
Clamping range, mm ²		10-70	10-70	10-95
Stripping length, mm		24	24	22
Torque, Nm / Screw		3.5 - 6 Hexagon socket M 6	3.5 - 6 Hexagon socket M 6	6 - 12 Hexagon socket M 8
Features				
Material of insulated housing Temperature range		PA 6.6 / -40 °C to +120 °C	PA 6.6 / -40 °C to +120 °C	PA 6.6 / -40 °C to +120 °C
Number of cross-connection channels / Test pick-off option		1/1	0/1	1/1
Accessories				
Cross-connection SQ, 2-pole		SQ 50/2		SQ 70/2
Cat. no.	Qty.	17255.0 5		17265.0 5
Cross-connection SQ, 3-pole		SQ 50/3		SQ 70/3
Cat. no.	Qty.	17256.0 5		17266.0 5
Cross-connection SQ, 4-pole		SQ 50/4		SQ 70/4
Cat. no.	Qty.	17257.0 5		17267.0 5
Cover		SAD 1/18/B WH	SAD 1/18/B WH	SAD 1/20/B WH
Cat. no.	Qty.	17284.7 10	17284.7 10	17286.7 10
Cover		SAD 1/18/B YE	SAD 1/18/B YE	SAD 1/20/B YE
Cat. no.	Qty.	17283.8 10	17283.8 10	17285.8 10
Pick-off terminal SMAG		MAG 50 BG	MAG 50 BG	MAG 50 BG
Cat. no.	Qty.	1121.2 10	1121.2 10	1121.2 10
Inlay profile EP		EP 50	EP 50	EP 50
Cat. no.	Qty.	2274.0 10	2274.0 10	2274.0 10
End stop SHES		SHES 35 BG	SHES 35 BG	SHES 35 BG
Cat. no.	Qty.	17259.2 20	17259.2 20	17259.2 20
Allen key socket wrench ISKS		ISKS 5	ISKS 5	ISKS 6
Cat. no.	Qty.	2818.0 1	2818.0 1	2772.0 1
Quick marking PMC SB		PMC SB 8/40 WH	PMC SB 8/40 WH	PMC SB 8/40 WH
Cat. no.	Qty.	9323.7 400	9323.7 400	9323.7 400

SSL 70/2A			SRK 120/2A		
					
M 8 			M 10 		
					
Protective earth terminal 2 connections			Feed-through terminal 2 connections		
Screw connection technology			Screw connection technology		
76.5 x 20.5 x 82			91 x 27 x 90		
76.5 x 20.5 x 84			91 x 27 x 91		
SSL 70/2A GNYE 			SRK 120/2A BG 		
17163.2			17165.2		
10			5		
SRK 120/2A BU 			17165.5		
			5		
IEC	UL	CSA	IEC	UL	CSA
			1000	1000	1000
			296/290	228	220
70/6-000			120/4-0000		
8/3			8/3		
B11/V-0			B13/V-0		
10-95/10-95			16-150/16-150		
10-70/10-70			16-120/16-95		
10-95			16-150		
22			27		
6-12 Hexagon socket M 8			12-20 Hexagon socket M 10		
PA 6.6 / -40 °C to +120 °C			PA 6.6 / -40 °C to +120 °C		
0/1			1/1		
			SQ 120/2		
			17278.0		5
			SQ 120/3		
			17279.0		5
			SQ 120/4		
			17280.0		5
SAD 1/20/B WH			SAD 1/27/B WH		
17286.7		10	17290.7		5
SAD 1/20/B YE			SAD 1/27/B YE		
17285.8		10	17291.8		5
MAG 50 BG			MAG 50 BG		
1121.2		10	1121.2		10
EP 50			EP 95		
2274.0		10	2275.0		10
SHES 35 BG			SHES 35 BG		
17259.2		20	17259.2		20
ISKS 6			ISKS 6		
2772.0		1	2772.0		1
PMC SB 8/40 WH			PMC SB 8/40 WH		
9323.7		400	9323.7		400

Optimally designed
for high stress:

Our feed-through terminals RK/ Measurement pick-off terminals MAG

Durability through maximum stability, that is one of the distinctive features of our range of feed-through as well as measurement pick-off terminals. Specialised construction of the clamping yoke, low contact resistance between wire and busbar - with these features, these terminals are optimally designed for high stress.



- **Two-piece insulating housing**
optimal for high stress
- **Specialised design**
ensures low contact resistances
- **High mechanical stability**
due to pins on the plastic housings

Specially designed,
perfectly insulated:

Feed-through terminals RK/ Measurement pick-off terminals MAG

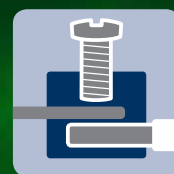

Screw connection
system



The **RK 50**, **RK 95**, **RK 150** and **RK 240** terminal blocks are made of a two-piece insulation housing. The specialised construction of the clamping yoke minimises the contact resistance between the wire and the busbar. The clamp is tightened using a hex-socket screw which creates the required torque together with the clamping yoke. Pegs are located on the plastic housings of the terminal blocks; these lock to adjacent terminals to increase the mechanical stability. A threaded **M 2.5** bolt can be attached to the injection-moulded pegs in order to further increase the mechanical stability. A diverse line of accessories offers a practical supplement to these products.

The advantages:

- A connection mechanism that has proven itself in billions of applications
- Connection of multiple wires is possible
- Cross-connection option for rated current
- Supplemental connections 50 to 240 mm²
- Comprehensive marking options

Features:

- Screw connection system
- Feed-through terminals 50 to 240 mm²
- Screwable external cross-connection system
- High contact force and contact security
- Material: PA 6.6 UL 94 V-2

Wide range of accessories

Measurement pick-off terminal MAG

The MAG measurement pick-off terminals allow you to tap into the voltage on the **RK 50**, **RK 95**, **RK 150** and **RK 240** terminal blocks when using wires with small cross-sections ranging from 0.2 to 10 mm². A special socket slot in the **RK 50** to **RK 240** terminal blocks enables the **MAG** supplemental connections to be added retroactively. They can be independently snapped on to the base housing of the terminal blocks. **MAG** terminals are individually snapped into the housing of the main terminal above the wire entry. The electrical contact is then established using the connection screw on the main-wire terminal of the busbar. This technical solution is safe, clever, and simplifies the wiring significantly. The rated voltage is 1000 V because of the total insulation provided by the pick-off terminal. The **PMC** quick marking system can be used for labelling the terminals.



Inlay plate EP

When connecting flat ribbon wires, you are required to attach an inlay plate in the clamping yoke. The **EP** inlay plates compensate for the V-shaped form of the clamping yoke (connection cage). This increases the safety and reliability of the connection for specialised applications.

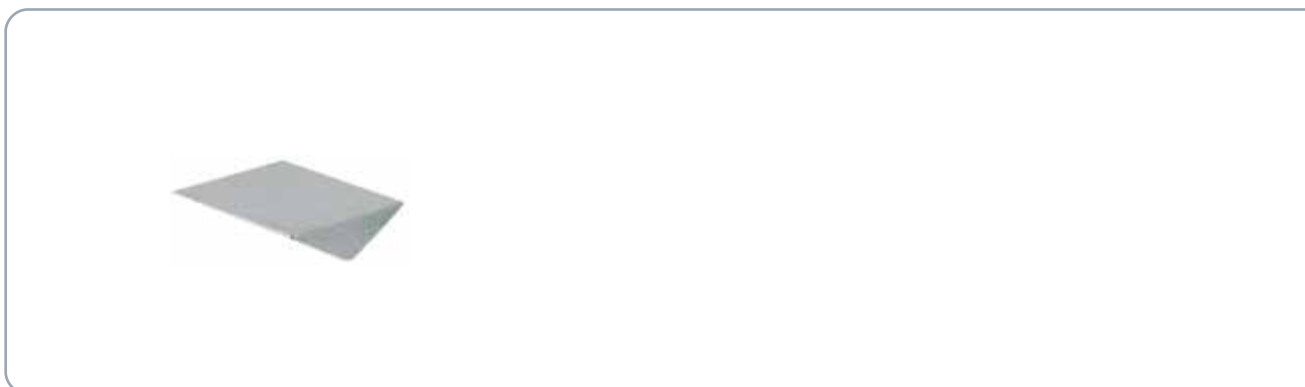

■ Individual covers AD

VDE regulations require that the mains terminals be covered. The yellow **AD** covers are marked with a lightning bolt symbol and are snapped on from above. They cover the screw heads on the terminal block so that the clamping point can not be reached while under live voltage.





■ External cross-connection AQI

The **RK 50**, **RK 95**, **RK 150** and **RK 240** terminals can be connected electrically to each other within the same rated cross-section range by using 2-pole or 3-pole external cross-connectors. The external cross-connectors are designed to match the rated current of the corresponding terminal block.

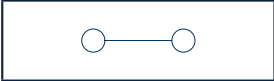
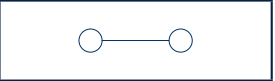
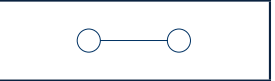

Feed-through terminals RK | Measurement pick-off terminals MAG

Screw connection system		RK 50	RK 95	RK 150
<ul style="list-style-type: none"> • Foot can be snapped on TS 32 and TS 35 DIN rails • Housing made from polyamide 6.6 UL 94-V-2 				
Connection diagram				
Description		Feed-through terminal 2 connections	Feed-through terminal 2 connections	Feed-through terminal 2 connections
Wire connect type		Screw connection technology	Screw connection technology	Screw connection technology
Size (L x W x H) with TS 32, mm		79 x 20 x 82	84 x 25 x 94	93 x 31 x 118.5
Size (L x W x H) with TS35x7.5 mm		79 x 20 x 76.5	84 x 25 x 88.5	93 x 31 x 112.8
Type / colour		RK 50 BG ●	RK 95 BG ●	RK 150 BG ●
Cat. no.	Qty.	1120.2 10	1122.2 10	1124.2 10
Type / colour		RK 50 BU ●	RK 95 BU ●	RK 150 BU ●
Cat. no.	Qty.	1120.5 10	1122.5 10	1124.5 10
Type / colour		RK 50 BK ●	RK 95 BK ●	RK 150 BK ●
Cat. no.	Qty.	1120.4 10	1122.4 10	1124.4 10
Type / colour		RK 50 GR ●	RK 95 GR ●	RK 150 GR ●
Cat. no.	Qty.	1120.6 10	1122.6 10	1124.6 10
Ratings		IEC UL CSA	IEC UL CSA	IEC UL CSA
Rated voltage (V)		1000 600 600	1000 600 600	1000 600 600
Rated current (A)		150 150 150	232 230 230	309 275 275
Rated wire cross-section, mm ² / AWG		50 / 1/0-6	95 / 4/0-2	150 / 300-2
Rated surge voltage kV / Contamination degree		8 / 3	8 / 3	8 / 3
Plug gauge acc. to EN 60 947-1 / Flamm. class acc. to UL 94		B10 / V-2	B12 / V-2	B14 / V-2
Connection data				
Single wire (solid) / stranded (flexible), mm ²		16-50 / 25-50	25-95 / 25-95	35-150 / 50-150
Finely-stranded / finely-stranded (w/ferrules acc. to DIN 46228/1), mm ²		25-50 / 25-50	25-95 / 25-95	50-150 / 50-150
Clamping range, mm ²		16-50	25-95	35-150
Stripping length, mm		27	30	38
Torque, Nm / Screw		6-8 Hexagon socket M 6	8-12 Hexagon socket M 8	14-20 Hexagon socket M 10
Banded wire up to mm		11.8 x 5	16 x 6	20 x 8
Features				
Material of insulated housing Temperature range		PA 6.6 / -40 °C to +105 °C	PA 6.6 / -40 °C to +105 °C	PA 6.6 / -40 °C to +105 °C
Number of cross-connection channels / Test pick-off option		- / -	- / -	- / -
Accessories				
Insulated cross-connection AQI		2-pole	AQI 2/95 YE	AQI 2/150 YE
Cat. no.	Qty.	2763.2 5	2765.2 5	2767.2 5
Insulated cross-connection AQI		3-pole	AQI 3/50 YE	AQI 3/150 YE
Cat. no.	Qty.	2764.2 5	2766.2 5	2768.2 5
Cover AD		AD 1/50/B YE	AD 1/95/B YE	AD 1/150/B YE
Cat. no.	Qty.	2810.0 10	2804.0 10	2806.0 10
Inlay profile EP		EP 50	EP 95	EP 150
Cat. no.	Qty.	2274.0 10	2275.0 10	2277.0 10
Measurement pick-off terminal MAG		MAG 50 BG	MAG 95 BG	MAG 150/240 BG
Cat. no.	Qty.	1121.2 10	1123.2 10	1125.2 10
End stop ES		ES 35/K/ST BG	ES 35/K/ST BG	ES 35/K/ST BG
Cat. no.	Qty.	2828.0 50	2828.0 50	2828.0 50
Allen key socket wrench ISKS		ISKS 5	ISKS 6	ISKS 8
Cat. no.	Qty.	2818.0 1	2772.0 1	2773.0 1
Screwdriver SDB				
Cat. no.	Qty.			
Quick marking PMC SB		PMC SB 6/50 WH	PMC SB 6/50 WH	PMC SB 6/50 WH
Cat. no.	Qty.	4702.7 500	4702.7 500	4702.7 500

RK 240	MAG 50	MAG 95	MAG 150/240	EP
				
				
				
Feed-through terminal 2 connections	Pick-off terminal 1 connection	Pick-off terminal 1 connection	Pick-off terminal 1 connection	Inlay plate
Screw connection technology	Screw connection technology	Screw connection technology	Screw connection technology	Screw connection technology
93 x 36 x 132 93 x 36 x 126.3				
RK 240 BG ● 1126.2 5	MAG 50 BG ● 1121.2 10	MAG 95 BG ● 1123.2 10	MAG 150/240 BG ● 1125.2 10	EP 50 2274.0 10
RK 240 BU ● 1126.5 5				EP 95 2275.0 10
RK 240 BK ● 1126.4 5				EP 150 2277.0 10
RK 240 GR ● 1126.6 5				EP 240 2360.0 10
IEC 1000 600 600 415 370 370 240/500-2/0 8/3 B16/V-2	IEC 1000 57 10/22-8 6/3 A5/V-2	IEC 1000 57 10/22-8 6/3 A5/V-2	IEC 1000 57 10/22-8 6/3 A5/V-2	
70-240/70-240 70-240/70-185 70-240 38 14-20 Hexagon socket M 10 20 x 12	0.2-10/0.2-10 0.2-10/0.2-10 0.2-10 12 1.2-2.0 Slotted M 4	0.2-10/0.2-10 0.2-10/0.2-10 0.2-10 12 1.2-2.0 Slotted M 4	0.2-10/0.2-10 0.2-10/0.2-10 0.2-10 12 1.2-2.0 Slotted M 4	
PA 6.6 / -40 °C to +105 °C -/-	PA 6.6 / -40 °C to +105 °C -/-	PA 6.6 / -40 °C to +105 °C -/-	PA 6.6 / -40 °C to +105 °C -/-	
AQI 2/240 YE 2769.2 5				
AQI 3/240 YE 2770.2 5				
AD 1/240/B YE 2808.0 10				
EP 240 2360.0 10				
MAG 150/240 BG 1125.2 10				
ES 35/K/ST BG 2828.0 50				
ISKS 8 2773.0 1				
	SDB 0.8 x 4.0 1087.0 1	SDB 0.8 x 4.0 1087.0 1	SDB 0.8 x 4.0 1087.0 1	
PMC SB 6/50 WH 4702.7 500	PMC SB 6/50 WH 4702.7 500	PMC SB 6/50 WH 4702.7 500	PMC SB 6/50 WH 4702.7 500	

Connection security has a name: **Our stud connection system HSK**

The range of **HSK** stud terminals from CONTA-CLIP offers secure connections for all energy-transmitting applications. The stable connection, low voltage drop and the use of self-extinguishing material ensure a high level of security.

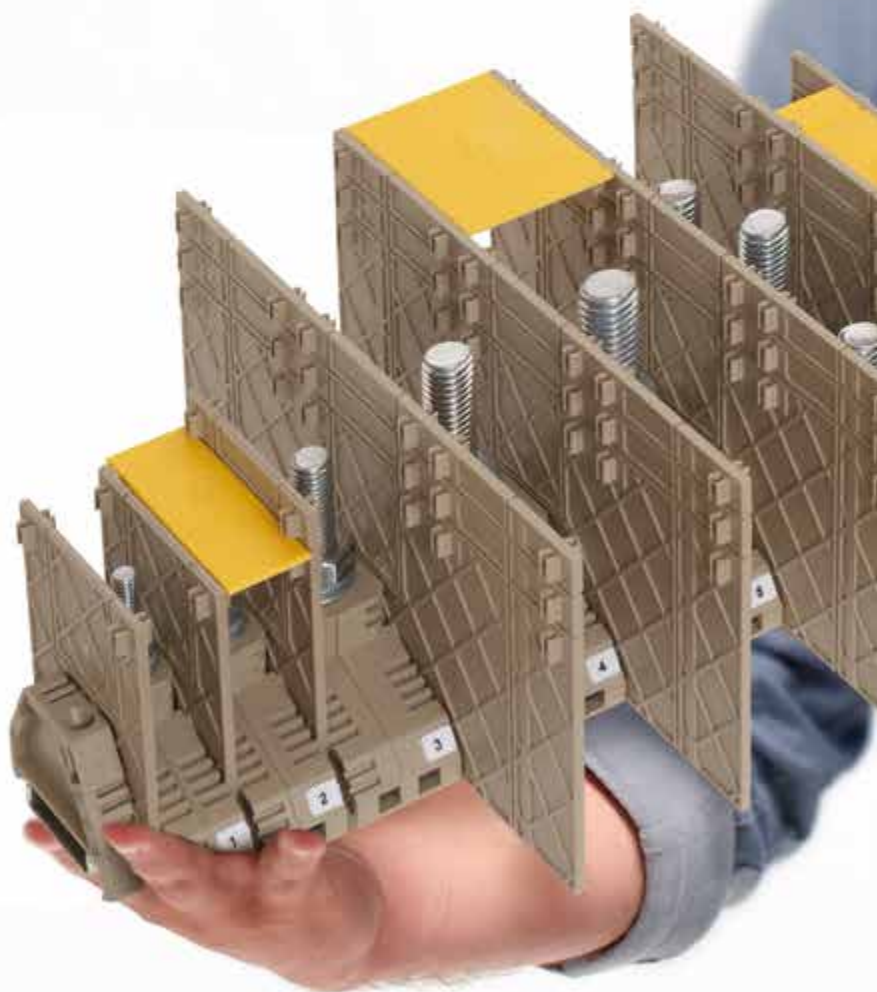

- 
- **Secure connection technology**
for all applications
 - **User-friendly handling**
facilitates installation
 - **Cost-optimised line of accessories**
reduces inventory costs

For all energy-intensive applications:
The HSK stud terminal programme



Stud connection system

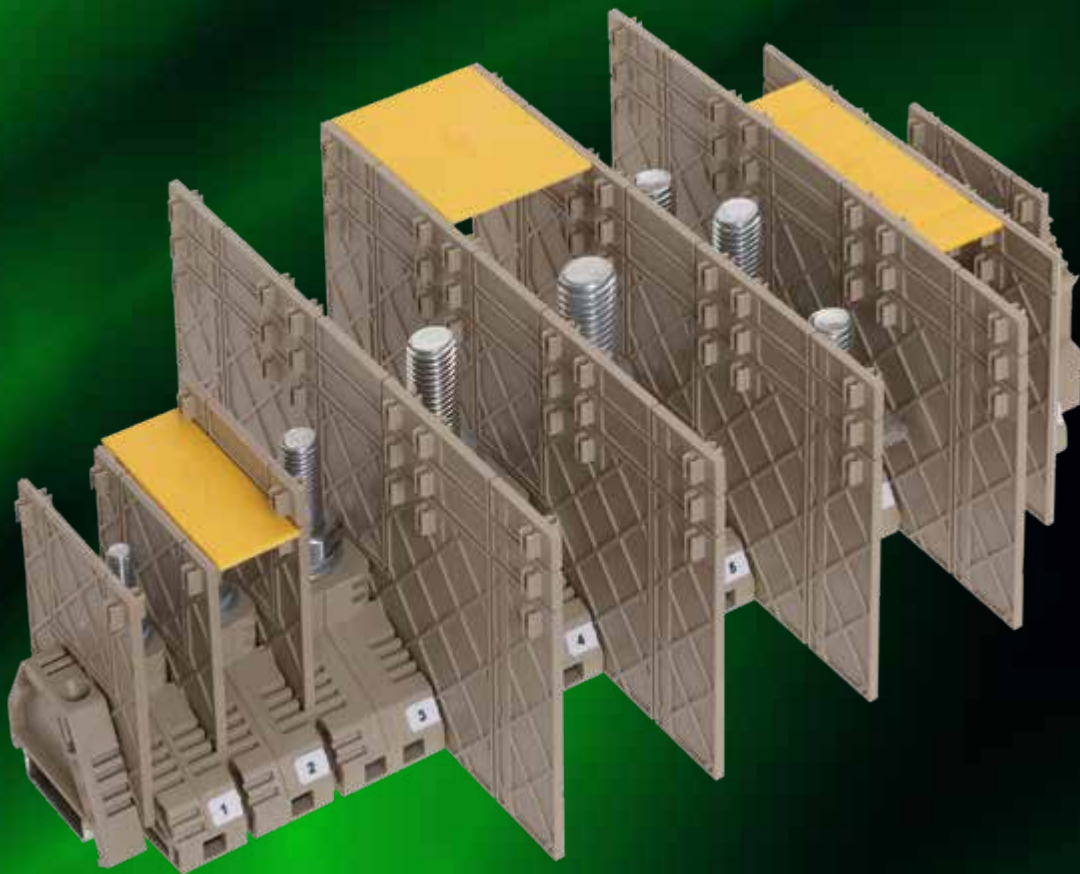

The wide-range of products is suitable for all applications in which energy is transmitted. Depending on the conductor cross-section, stud terminals with threaded studs from **M5** to **M12** can be used. The rated current is from 76 A to 269 A with a rated voltage of 1000 V. The wire connection range is from 0.2 mm² to 120 mm². Wires with crimped cable lugs are applied to threaded bolts and then connected securely by tightening the hex nut. Optimal security is guaranteed by the low voltage drop and by the use of self-extinguishing material with a V-0 (UL94) flammability rating.

Designed for mounting onto **TS 35** DIN rails, the stud terminals can be adapted with accessories such as **TW** partitions and **AD** covers to suit application requirements. These products are easy to use. They also stand out with their cost-optimised line of accessories which results in reduced storage costs and assembly times.

The advantages:

- Safe and versatile connection system
- Multi-wire connection through several cable lugs is possible
- Simple cross-connection options
- Convenient installation of the touch guard
- Comprehensive marking options

Features:

- Stud connection system
- Feed-through terminals from 35 to 300 mm²
- Screwable cross-connection rails
- High contact force and contact security
- Material: PA 6.6 UL 94 V-0

Distinctive features

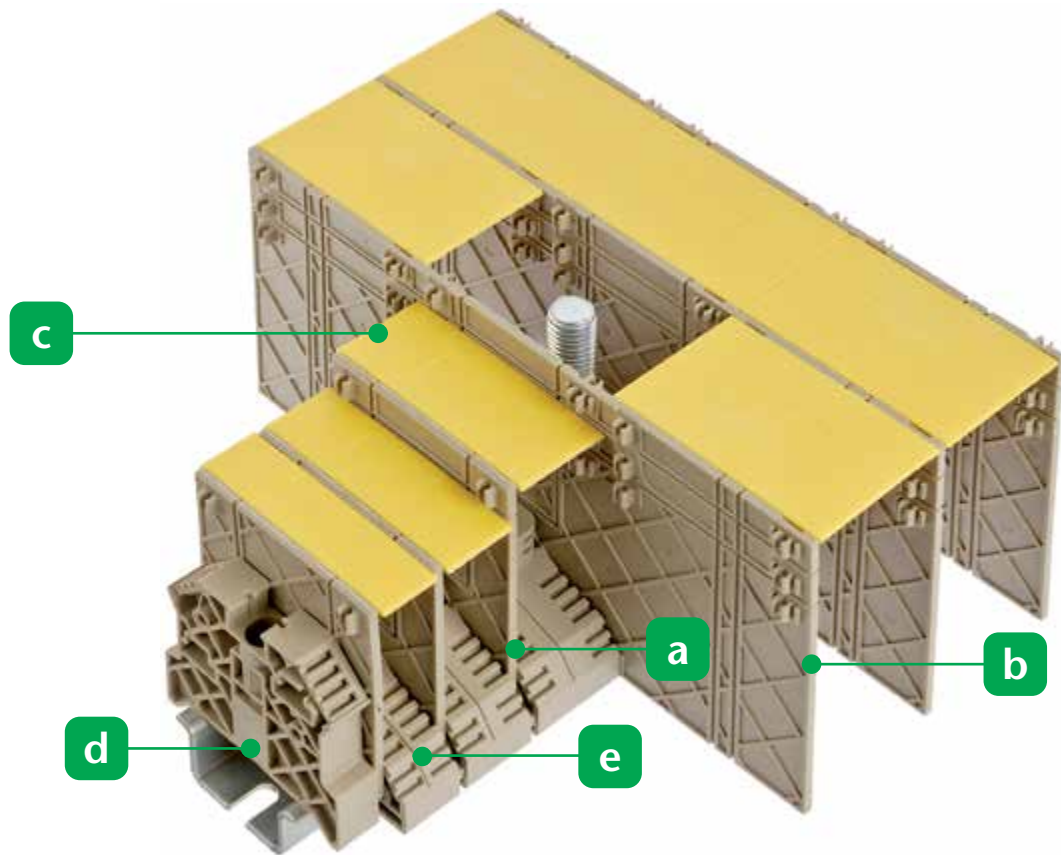

a Base terminal HSK

Polyamide PA6.6 UL 94, flamm. class V-0, self-extinguishing without burning drops

b Partition plates TW

Special **TW** partitions can be securely snapped into the terminal housing. This allows for good visual and electrical separation of the terminals. In addition, they are ready for fitting with snap-on covers.

c Covers AD

The **AD** covers can be snapped on, simply and securely, to the matching clips in the partitions. In this quick and reliable way, touch-safe protection of the terminal points is always guaranteed.

d End stop ES 35/K/ST

The **ES 35/K/ST** end stops grip both sides of the DIN rail with steel clamps. They are a secure method of mechanical attachment in terminal rail design. The plastic PA -6.6 housing of the brackets encapsulates the metal parts.

e Labelling | Marking

The stud terminals have a labelling surface which is optimally suited for our Pocket-Maxicard **PMC (PMC BSTR 6/30)** standard marking systems.

Handling

HSK terminals with one stud:

Up to four wires can be connected easily. Cable lugs are crimped onto the wire ends to facilitate the connection. The cable lugs should be aligned opposite each other when there are multiple lugs per side. When the nut is tightened, the flats of the cable lugs clamp together and a secure connection is ensured.

HSK terminals with two studs:

Cable lugs are crimped onto the wire ends to facilitate the connection. The cable lugs are placed on the studs between the shake-proof washer and the busbar. The cable lugs should be aligned opposite each other when there are two lugs per stud. When the nut is tightened, the flats of the cable lugs clamp together and a secure connection is ensured.

The features in detail

Stud connection

- Stud sizes from M5 to M12
- Wire with cable lug acc. to DIN 46234: up to 300 mm²
- Four cable lugs can be connected per stud

Easy to use

- Single-stud terminals: Put the cable lug on the stud between the base washer and the shake-proof washer
- Double-stud terminals: Put the cable lug on the stud between the busbar and the shake-proof washer
- By tightening the steel nut, the cable lugs forms a contact with the other cable lug or with the busbar. (B/B versions)

Cross-connections

- 2 -pole and 3-pole version
- Possible to distribute potentials between the different sizes
- Designed for the rated current of the corresponding stud terminal
- Speedy distribution of potentials helps save time

Terminal holder made of polyamide 6.6 V-0

- Self-extinguishing UL 94 V-0
- Creepage-current protected, CTI = 600
- Temperature resistance -40 °C to +120 °C
- Halogen-free, silicone-free, phthalate-free
- Meets the requirements of EN 45545-2, NFF 1601 F and NFF 1601 I

Safe to handle

- Touch-protection provided by partitions and yellow covers

Secure contacts

- Maintenance-free; subsequent tightening of the nut is not needed
- High contact strength and vibration resistant because of the safety/spring washer
- Direct contact of cable lugs, or contact via copper busbar



Standards

The following standard terminal block requirements are fulfilled:

- EN 60947-7-1
- EN 50124-1
- DIN EN 61373

Handling and accessories

The use of TW partition plates

The **HSK...B** single-stud terminals and the **HSK...B/B** double-stud versions make use of two **TW** partitions. The partitions can be adjusted to the rated cross-section by using the predetermined breakage points. For your further assistance, the **TW** partitions list the cross-section range and additional dimension lines. Remember that the clearance and creepage distances for a rated voltage of 1000 V, and dependent on the corresponding cross-section, must be followed.

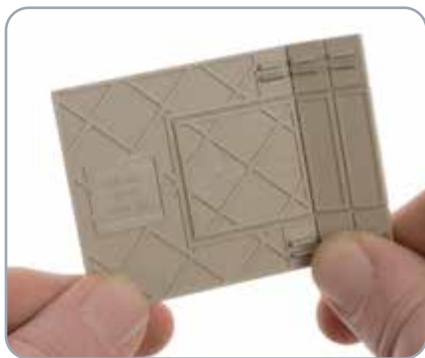

Simple breaking off of the TW partition

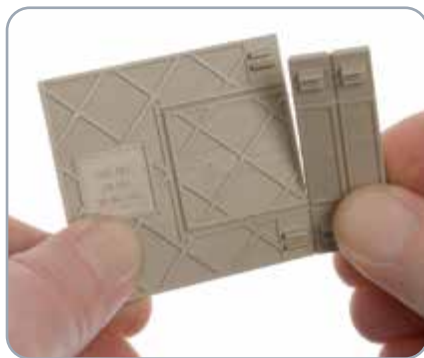

HSK installed with TW partition plate and AD cover



TW partition with dimension lines

Snapping on the partition plates to the HSK high-power stud terminals

You can snap on the **TW** partition plates and the **HSK** stud terminals by using the locking pegs on the partition. The pegs lock into the foot of the stud terminals.



Snapping together the TW partition with a high-power HSK stud terminal

Using the AD covers

An individual **AD** cover is available for each width of stud terminal. Their length takes into consideration the creepage and clearance distances on the twin-stud terminals. If the covers are to be used with the one-stud versions, you can shorten the cover by breaking it along the breakage points. For your further assistance, the **AD** covers have additional dimension lines on them. Locking pegs are used to mount the **AD** cover. The cover snaps in securely from above to the **TW** partition plates. Thus a high degree of touch-safety is guaranteed.















Simple breakage with the AD cover



AD cover with dimension lines

High-power stud terminals HSK

Stud connection system		HSK 16/M5 B			HSK 35/M6 B			HSK 50/M8 B		
<ul style="list-style-type: none"> • Foot base can be snapped on TS 35 DIN rail • Stud connection • Housing made of polyamide 6.6 UL 94 V-0 										
Connection diagram										
Description		High-power terminal 1 connection			High-power terminal 1 connection			High-power terminal 1 connection		
Wire connect type		Stud connection			Stud connection			Stud connection		
Size (L x W x H) with TS 35 x 7.5 mm		67 x 13 x 55.5			67 x 16 x 55.5			67 x 21 x 63.5		
Size (L x W x H) with TS 35 x 7.5 mm with TW/AH		67 x 13 x 58			67 x 16 x 58			67 x 21 x 66		
Type / colour		HSK 16/M5 B BG ●			HSK 35/M6 B BG ●			HSK 50/M8 B BG ●		
Cat. no.	Qty.	17000.2 10			17001.2 10			17002.2 10		
Ratings		IEC	CSAus	CSA	IEC	CSAus	CSA	IEC	CSAus	CSA
Rated voltage (V)		1000	1000	1000	1000	1000	1000	1000	1000	1000
Rated current (A)		76	60	60	125	115	115	150	125	125
Rated wire cross-section, mm ² / AWG		16 / 10-0			35 / 14-2			50 / 14-1/0		
Rated surge voltage kV / Contamination degree		8 / 3			8 / 3			8 / 3		
Plug gauge acc. to EN 60 947-1 / Flamm. class acc. to UL 94		-/V-0			-/V-0			-/V-0		
Connection data										
Clamping range, mm ²		≤ 16			≤ 35			≤ 50		
Stud size		M 5			M 6			M 8		
Clampable cable lug										
DIN 46234/1 cable lug per side mm		0.1-16			2.5-35			2.5-50		
DIN 46234/2 cable lugs per side mm		0.1-16			2.5-35			2.5-50		
DIN 46235/1 cable lug per side mm		6.0-10			6.0-35			6.0-35		
DIN 46235/2 cable lugs per side mm		6.0-10			6.0-25			6.0-35		
Torque, Nm		2.0-4.0, 8.5			3.0-6.0, 12.4			6.0-12, 16.9		
Features										
Material of insulated housing Temperature range		PA 6.6 / -40 °C to +120 °C			PA 6.6 / -40 °C to +120 °C			PA 6.6 / -40 °C to +120 °C		
Number of cross-connection channels / Test pick-off option		1 / -			1 / -			1 / -		
Accessories										
Partition plate TW up to 1000 V		TW 16-120 BG			TW 16-120 BG			TW 16-120 BG		
Cat. no.	Qty.	17018.2 20			17018.2 20			17018.2 20		
Partition plate TW up to 1000 V for insul. cable lugs										
Cat. no.	Qty.									
Cover profile AD		AD 16 YE			AD 35 YE			AD 50 YE		
Cat. no.	Qty.	17019.8 20			17020.8 20			17021.8 20		
Cross-connection Q, 2-pole		QS 2/16			QS 2/35			QS 2/50		
Cat. no.	Qty.	17008.0 10			17010.0 10			17012.0 10		
Cross-connection Q, 3-pole		QS 3/16			QS 3/35			QS 3/50		
Cat. no.	Qty.	17009.0 10			17011.0 10			17013.0 10		
Cross-connection Q from M6 to M8, 2-pole					QS 2 HSK 35/M6 - M8			QS 2 HSK 35/M6 - M8		
Cat. no.	Qty.				17028.2 1			17028.2 1		
Cross-connection Q from M6 to M10, 3-pole					QS 3 HSK 35/M6 - M10/2					
Cat. no.	Qty.				17029.2 1					
End stop ES		ES 35/K/ST BG			ES 35/K/ST BG			ES 35/K/ST BG		
Cat. no.	Qty.	2828.0 50			2828.0 50			2828.0 50		
Quick marking PMC SB		PMC SB 6/50 WH			PMC SB 6/50 WH			PMC SB 6/50 WH		
Cat. no.	Qty.	4702.7 500			4702.7 500			4702.7 500		

HSK 120/M10 B	HSK 120/M12 B	HSK 35/M6 B/B	HSK 50/M8 B/B	HSK 120/M10 B/B
 M 5	 M 6	 M 6	 M 8	 M 10
				
High-power terminal 1 connection	High-power terminal 1 connection	High-power terminal 2 connections	High-power terminal 2 connections	High-power terminal 2 connections
Stud connection 67 x 32 x 73.5 67 x 32 x 76	Stud connection 67 x 32 x 73.5 67 x 32 x 76	Stud connection 67 x 16 x 55.5 67 x 16 x 61.5	Stud connection 67 x 21 x 63.5 120 x 21 x 71.5	Stud connection 67 x 32 x 73.5 156 x 32 x 78.5
HSK 120/M10 B BG ●	HSK 120/M12 B BG ●	HSK 35/M6 B/B BG ●	HSK 50/M8 B/B BG ●	HSK 120/M10 B/B BG ●
17003.2	17004.2	17005.2	17006.2	17007.2
10	10	10	10	10
IEC UL CSA	IEC UL CSA	IEC UL CSA	IEC UL CSA	IEC UL CSA
1000 1000 1000	1000 1000 1000	1000 1000 1000	1000 1000 1000	1000 1000 1000
269 255 220	269 255 220	125 110	150 150	269 225 225
120/10-Kcmil 250	120/10-Kcmil 250	35/14-2	50/14-1/0	120/10-Kcmil 250
8/3	8/3	8/3	8/3	8/3
-/V-0	-/V-0	-/V-0	-/V-0	-/V-0
≤ 120	≤ 120	≤ 35	≤ 50	≤ 120
M 10	M 12	M 6	M 8	M 10
6-120	6-120	2.5-35	2.5-50	6-120
6-120	6-120	2.5-35	2.5-50	6-120
10-95	10-95	6.0-25	6.0-35	10-95
10-95	10-95	6.0-25	6.0-35	10-95
10-20, 20.0	14-31, 20.0	3.0-6.0, 12.4	6.0-12, 16.9	10-20, 20.9
PA 6.6 / -40 °C to +120 °C	PA 6.6 / -40 °C to +120 °C	PA 6.6 / -40 °C to +120 °C	PA 6.6 / -40 °C to +120 °C	PA 6.6 / -40 °C to +120 °C
1/-	1/-	1/-	1/-	1/-
TW 35-120/B/B BG	TW 35-120/B/B BG	TW 35-120/B/B BG	TW 35-120/B/B BG	TW 35-120/B/B BG
17022.2	17022.2	17022.2	17022.2	17022.2
20	20	20	20	20
TW 16-120 BG	TW 16-120 BG			
17018.2	17018.2			
20	20			
AD 120 YE	AD 120 YE	AD 35 YE	AD 50 YE	AD 120 YE
17026.8	17026.8	17020.8	17021.8	17026.8
20	20	20	20	20
QS 2/120/10	QS 2/120/12	QS 2/35	QS 2/50	QS 2/120/10
17014.0	17016.0	17010.0	17012.0	17014.0
10	10	10	10	10
QS 3/120/10	QS 3/120/12	QS 3/35	QS 3/50	QS 3/120/10
17015.0	17017.0	17011.0	17013.0	17015.0
10	10	10	10	10
		QS 2 HSK 35/M6 - M8	QS 2 HSK 35/M6 - M8	
		17028.2	17028.2	
		1	1	
Q3 HSK 35/M6-M10/2		QS 3 HSK 35/M6 - M10/2		QS 3 HSK 35/M6 - M10/2
17029.2		17029.2		17029.2
1		1		1
ES 35/K/ST BG	ES 35/K/ST BG	ES 35/K/ST BG	ES 35/K/ST BG	ES 35/K/ST BG
2828.0	2828.0	2828.0	2828.0	2828.0
50	50	50	50	50
PMC SB 6/50 WH	PMC SB 6/50 WH	PMC SB 6/50 WH	PMC SB 6/50 WH	PMC SB 6/50 WH
4702.7	4702.7	4702.7	4702.7	4702.7
500	500	500	500	500

CONTA-CLIP presents: **HSKG** - the newest generation of stud terminals

Connection security at the highest level - this is what the new generation of stud terminals from the HSKG range offers. This connection system opens up maximum flexibility.



- **Maximum connection security**
for all applications
- Designed for a **rated voltage up to 1000 V**
- **High degree of contact protection**
due to hinged cover

High flexibility
for a wide variety of applications:
the range of HSKG products



Stud connection
system



Depending on the wire cross-section, the **HSKG** stud terminals can be used with M6, M8, M10, M12 and M16 threaded studs.

The rated current is from 125 A to 520 A with a rated voltage of 1000 V. The wire connection range is from 2.5 mm² to 300 mm². Wires with crimped cable lugs are applied to threaded bolts and then connected securely to the busbar by tightening the hex nut. Optimal security is guaranteed by the low voltage drop and by the use of self-extinguishing material with a V-0 (UL94) flammability rating.

When used together with the **ADH** hinged covers, the **HSKG** stud terminals provide outstanding finger and touch protection. The **ADH** cover is easy to mount; it simply snaps into the side walls of the stud terminals as it is closed. In this quick and reliable way, touch-safe protection of the terminal points is always guaranteed.

The advantages:

- Safe and versatile connection system
- Multi-wire connection through several cable lugs is possible
- Simple cross-connection options
- Convenient installation of the touch guard
- Comprehensive marking options

Features:

- Stud connection system
- Feed-through terminals from 35 to 300 mm²
- Screwable cross-connection rails
- High contact force and contact security
- Material: PA 6.6 UL 94 V-0

Distinctive features

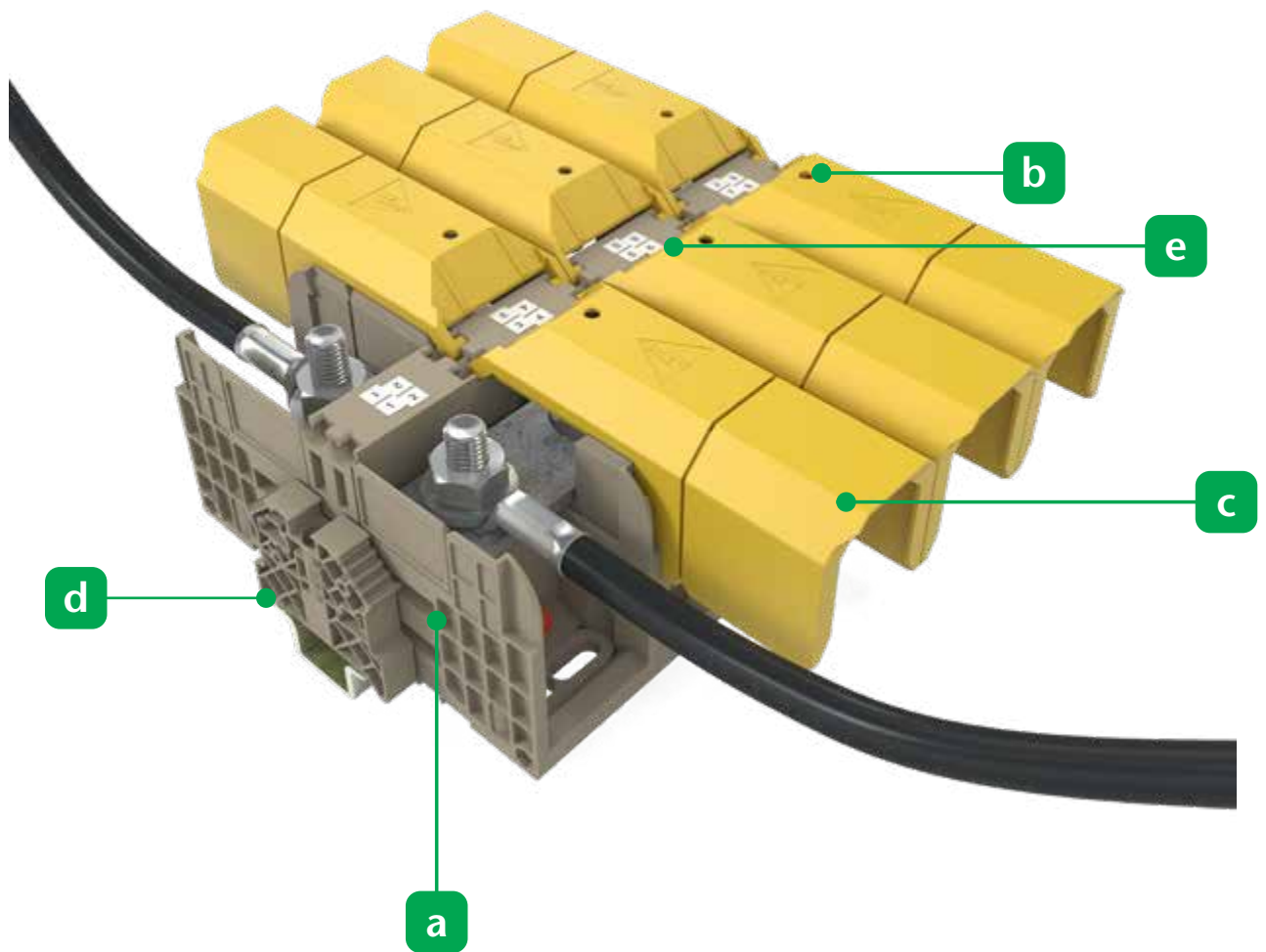

a Base terminal HSKG

CONTA-CLIP stud terminals can be arranged as required on standard **TS 35** DIN rails in accordance with EN 60715. Direct mounting is possible.

b Measurement port

The **ADH** cover has an opening used to measure the voltage.

c Covers ADH

The **AD** covers can be snapped on, simply and securely, to the matching opening clips in the partitions. In this quick and reliable way, touch-safe protection of the terminal points is always guaranteed.

d End stop ES 35/K/ST

The **ES 35/K/ST** end stops grip both sides of the DIN rail with steel clamps. They are a secure method of mechanical attachment in terminal rail design. The plastic PA-6.6 housing of the brackets encapsulates the metal parts.

e Labelling | Marking

The stud terminals have a labelling surface which is optimally suited for CONTA-CLIP's **PMC** Pocket-Maxicard standard marking systems.

Handling

HSKG terminals with two studs:

Cable lugs are crimped onto the wire ends to facilitate the connection. The cable lugs are placed on the studs between the shake-proof washer and the busbar. The cable lugs should be aligned opposite each other when there are two lugs per stud. When the nut is tightened, the flats of the cable lugs clamp together and a secure connection is ensured.

Standards

The following standard terminal block requirements are fulfilled:

- EN 60947-7-1
- EN 50124-1
- DIN EN 61373

Terminal holders and covers made from polyamide 6.6 V-0

- Self-extinguishing UL 94 V-0
- Creepage-current protected, CTI = 600
- Temperature resistance -40 °C to +120 °C
- Halogen-free, silicone-free, phthalate-free
- Meets the requirements of EN 45545-2, NFF 1601 F and NFF 1601 I

The features in detail

Stud connection

- Stud sizes: M6, M8, M10, M12 to M16
- Wire with cable lug, according to DIN 46234, up to 300 mm²
- One or two cable lugs can be connected per stud

Easy to use

- Place cable lugs on the stud
- By tightening the steel nut, the cable lugs forms a contact with the other cable lug or with the busbar.

Secure contacts

- Maintenance-free; subsequent tightening of the nut is not needed
- High contact strength and vibration resistance provided by the safety/spring washer and combi-nut
- Direct contact of cable lugs, or contact via copper busbar

Mounting options

- Sliding lock on both sides: can be attached to **TS35** DIN rail
- Direct mount possible using the integrated slots in the housing base

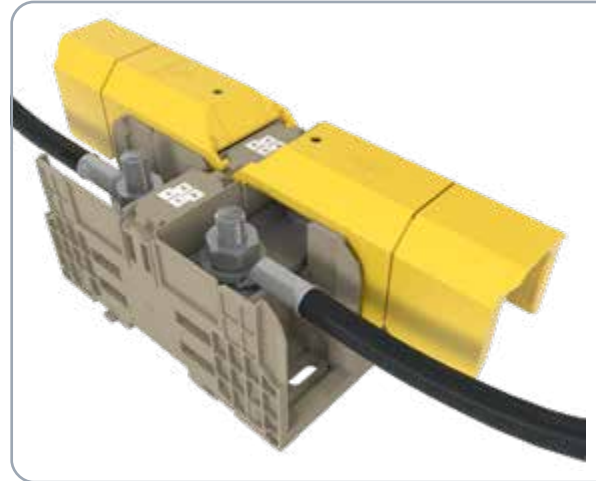

Connecting the wire

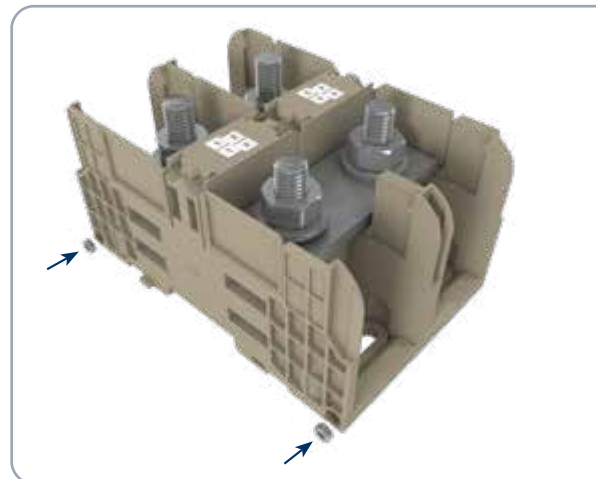

Additional bolting options

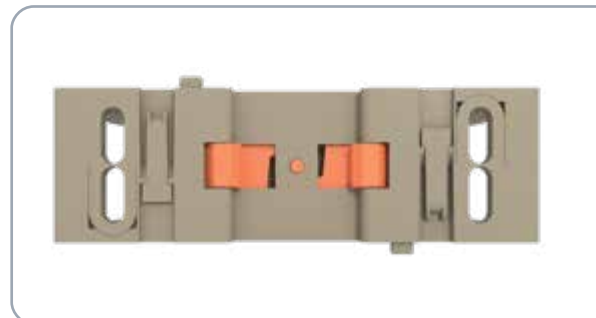

TS mount / direct mount

Handling and accessories

Cross-connections

- 2 -pole and 3-pole version
- Possible to distribute potentials between the different sizes
- Designed for the rated current of the corresponding stud terminal
- Speedy distribution of potentials helps save time

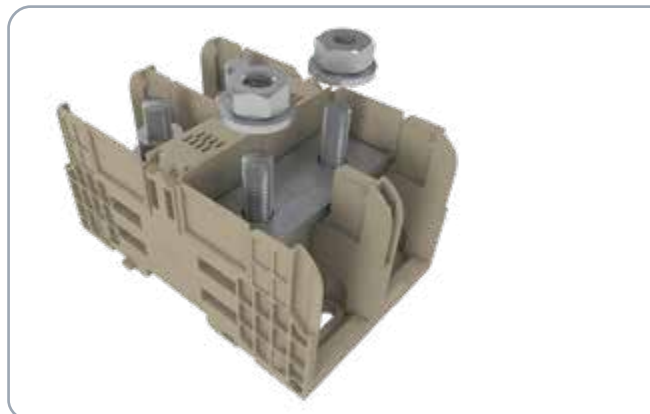

Attaching the cross-connections

Labelling and testing

- Mounting positions for standard markers
- Openings in the **ADH** covers for measuring voltage

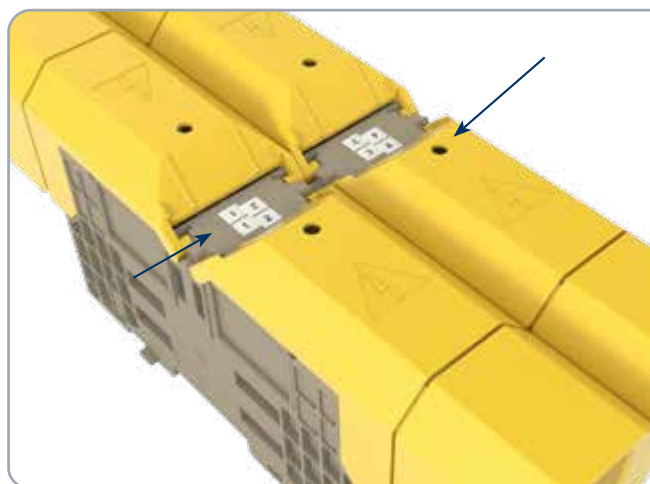

Labelling options PMC and voltage measurement opening

Using the ADH covers

An individual **ADH** cover is available for each width of stud terminal. Their length takes into consideration the creepage and clearance distances. It is possible to shorten the covers using the predetermined breaking points. The **ADH** cover is attached by pressing the cover down onto the base terminal so that the cover snaps onto the terminal.





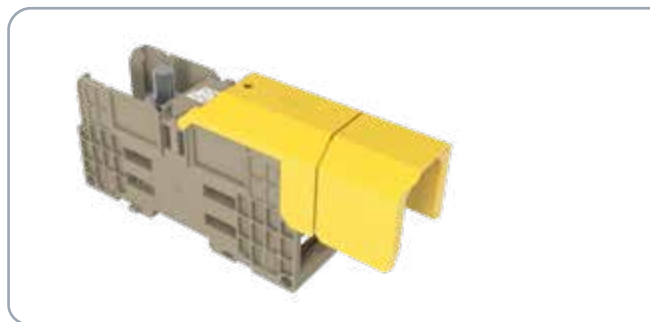

ADH open

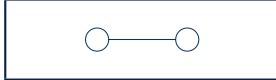
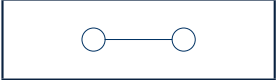

ADH closed

HSKG high-power stud terminals

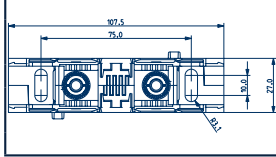
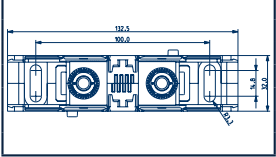
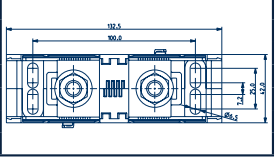
Stud connection system		HSKG 35/M6/B/B	HSKG 70/M8/B/B	HSKG 120/M10/B/B
<ul style="list-style-type: none"> • Foot base can be snapped on TS 35 DIN rail • Direct mounting • Stud connection • Housing made of polyamide 6.6 UL 94 V-0 				
Connection diagram				
Dimensional diagram				
Wire connect type		Stud connection	Stud connection	Stud connection
Size (L x W x H) with TS35 x 7.5 mm		107 x 27 x 51	132 x 32 x 61	133 x 42 x 72
Size (L x W x H) with TS35 x 7.5, including ADH on both sides		131 x 27 x 60	180 x 32 x 70	226 x 42 x 80
Type / colour		HSKG 35/M6/B/B BG ●	HSKG 70/M8/B/B BG ●	HSKG 120/M10/B/B BG ●
Cat. no.	Qty.	17170.2	17035.2	17023.2
Ratings		IEC	UL	cUL
Rated voltage (V)		1000	1000	1000
Rated current (A)		125	115	130
Rated wire cross-section, mm ² / AWG		35 / 14–2	70 / 14–00	120 / 10–Kcmil 250
Rated surge voltage kV / Contamination degree		8 / 3	8 / 3	8 / 3
Flamm. class acc. to UL 94		V-0	V-0	V-0
Connection data				
Clamping range, mm ²		2.5–50	2.5–95	≤ 120
Stud size		M 6	M 8	M 10
Clampable cable lug				
DIN 46234 / 1 cable lug per side, mm ²		2.5–50	2.5–95	6–150
DIN 46234 / 2 cable lugs per side, mm ²				6–120
DIN 46235 / 1 cable lug per side, mm ²		6–25	16–70	16–150
DIN 46235 / 2 cable lugs per side, mm ²				16–120
Torque, Nm		3–6	6–12	10–20
Features				
Material of insulated housing Temperature range		PA 6.6 / -40 °C to +120 °C	PA 6.6 / -40 °C to +120 °C	PA 6.6 / -40 °C to +120 °C
Accessories				
Cover profile ADH		ADH 35 BG	ADH 70 BG	ADH 120 BG
Cat. no.	Qty.	17275.2	17268.2	17025.2
Cover profile ADH		ADH 35 BU	ADH 70 BU	ADH 120 BU
Cat. no.	Qty.	17275.5	17268.5	17025.5
Cover profile ADH		ADH 35 YE	ADH 70 YE	ADH 120 YE
Cat. no.	Qty.	17275.8	17268.8	17025.8
QS cross-connection rail		QS 2/35/6	QS 2/70/8	QS 2/120/10
Cat. no.	Qty.	17276.0	17269.0	17241.0
QS cross-connection rail		QS 3/35/6	QS 3/70/8	QS 3/120/10
Cat. no.	Qty.	17277.0	17270.0	17242.0
End stop ES		ES 35/K/ST BG	ES 35/K/ST BG	ES 35/K/ST BG
Cat. no.	Qty.	2828.0	2828.0	2828.0
Quick marking PMC SB		PMC SB 6/50 WH	PMC SB 6/50 WH	PMC SB 6/50 WH
Cat. no.	Qty.	4702.7	4702.7	4702.7

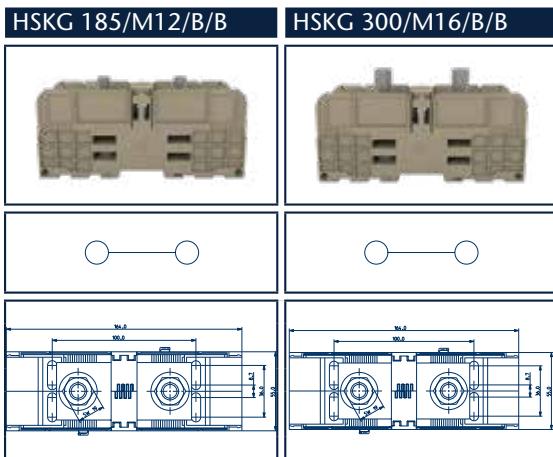

Stud connection				Stud connection			
164 x 55 x 78				164 x 55 x 86			
288 x 55 x 90				288 x 55 x 90			
HSKG 185/M12/B/B BG ●				HSKG 300/M16/B/B BG ●			
17024.2		5		17027.2		5	
IEC	UL	cUL		IEC	UL	cUL	
1000	1000	1000		1000	1000	1000	
353	380	360		520	510	510	
185 / 10 – Kcmil 500				300 / 10 – Kcmil 600			
8 / 3				8 / 3			
V-0				V-0			
≤ 185				≤ 300			
M 12				M 16			
10 – 240				25 – 240			
10 – 185				50 – 240			
25 – 240				50 – 300			
25 – 185				50 – 240			
14 – 31				25 – 60			
PA 6.6 / -40 °C to +120 °C				PA 6.6 / -40 °C to +120 °C			
ADH 185/300 BG				ADH 185/300 BG			
17123.2		10		17123.2		10	
ADH 185/300 BU				ADH 185/300 BU			
17123.5		10		17123.5		10	
ADH 185/300 YE				ADH 185/300 YE			
17123.8		10		17123.8		10	
QS 2/185/12				QS 2/300/16			
17243.0		10		17245.0		10	
QS 3/185/12				QS 3/300/16			
17244.0		10		17246.0		10	
ES 35/K/ST BG				ES 35/K/ST BG			
2828.0		50		2828.0		50	
PMC SB 6/50 WH				PMC SB 6/50 WH			
4702.7		500		4702.7		500	

Types and catalogue numbers, *alphabetic*

Type	Cat. no.	Page	Type	Cat. no.	Page	Type	Cat. no.	Page
A			ISKS 6	2772.0	42, 43, 50	QS 3/120/10	17015.0	61
AD 1/150/B YE	2806.0	50	ISKS 8	2773.0	50, 51	QS 3/120/10	17242.0	70
AD 1/240/B YE	2808.0	51				QS 3/120/12	17017.0	61
AD 1/50/B YE	2810.0	50	M			QS 3/16	17009.0	60
AD 1/95/B YE	2804.0	50	MAG 150/240 BG	1125.2	50, 51	QS 3/185/12	17244.0	71
AD 120 YE	17026.8	61	MAG 50 BG	1121.2	42, 43, 50, 51	QS 3/300/16	17246.0	71
AD 16 YE	17019.8	60	MAG 95 BG	1123.2	50, 51	QS 3/35	17011.0	60, 61
AD 35 YE	17020.8	60, 61				QS 3/35/6	17277.0	70
AD 50 YE	17021.8	60, 61	P			QS 3/50	17013.0	60, 61
ADH 120 BG	17025.2	70	PMC SB 5/50 WH	4600.7	36	QS 3/70/8	17270.0	70
ADH 120 BU	17025.5	70	PMC SB 6/50 WH	4702.7	37, 50, 51, 60, 61, 70, 71	R		
ADH 120 YE	17025.8	70	PMC SB 7,5/40 So WH	3327.7	14, 22, 23, 24, 25, 26, 27	RK 150 BG	1124.2	50
ADH 185/300 BG	17123.2	71				RK 150 BK	1124.4	50
ADH 185/300 BU	17123.5	71				RK 150 BU	1124.5	50
ADH 185/300 YE	17123.8	71				RK 150 GR	1124.6	50
ADH 35 BG	17275.2	70				RK 240 BG	1126.2	51
ADH 35 BU	17275.5	70	PMC SB 7,5/40 WH	9326.7	14, 22, 23, 24, 25, 26, 27	RK 240 BK	1126.4	51
ADH 35 YE	17275.8	70	PMC SB 8/40 WH	9323.7	38, 39, 40, 41, 42, 43	RK 240 BU	1126.5	51
ADH 70 BG	17268.2	70				RK 240 GR	1126.6	51
ADH 70 BU	17268.5	70				RK 50 BG	1120.2	50
ADH 70 YE	17268.8	70				RK 50 BK	1120.4	50
AP 2,5-10 BG	2001.2	36, 37, 38, 39				PMC SB 7,5/40 WH	9326.7	14, 22, 23, 24, 25, 26, 27
AP 2,5-10 GN	2001.1	38, 39	PQI 4/2/PTKS RD	27084.9	14	RK 50 GR	1120.6	50
AQI 2/150 YE	2767.2	50	PQI 4/3/PTKS RD	27085.9	14	RK 95 BG	1122.2	50
AQI 2/50 YE	2763.2	50	PQI 4/5/PTKS RD	27086.9	14	RK 95 BK	1122.4	50
AQI 2/95 YE	2765.2	50	PTKS 4/1 GR	27080.6	14	RK 95 BU	1122.5	50
AQI 3/150 YE	2768.2	50	PTKS 4/2 GR	27081.6	14	RK 95 GR	1122.6	50
AQI 3/240 YE	2770.2	51	PTKS 4/2 GR	27081.6	14	S		
AQI 3/50 YE	2764.2	50	PTKS 4/SI 5x20 GR	27087.6	15	SAD 1/12/B WH	17248.7	40, 41
AQI 3/95 YE	2766.2	50	PTKS 4/SI 6,3x32 GR	27088.6	15	SAD 1/12/B YE	17249.8	40, 41
E			PTKS-ADH 4/2 GR	27082.6	14	SAD 1/16/B WH	17282.7	41
EP 150	2277.0	50, 51	PTKS-ADH 4/2 OG	27082.3	14	SAD 1/16/B YE	17281.8	41
EP 240	2360.0	51	PTKS-ADH 4/3 GR	27083.6	14	SAD 1/18/B WH	17284.7	42
EP 50	2274.0	42, 43, 50, 51	PTKS-ADH 4/3 OG	27083.3	14	SAD 1/18/B YE	17283.8	42
EP 95	2275.0	43, 50, 51	PTKS-ADH 4/SI 5x20 GR	27089.6	15	SAD 1/20/B WH	17286.7	42, 43
			PTKS-ADH 4/SI 6,3x32 GR	27089.6	15	SAD 1/20/B YE	17285.8	42, 43
ES 35/K/ST BG	2828.0	50, 51, 60, 61, 70, 71	PTKS-ADH 4/SI 5x20 OG	27089.3	15	SAD 1/27/B WH	17290.7	43
H			PTKS-ADH 4/SI 6,3x32 GR	27090.6	15	SAD 1/27/B YE	17291.8	43
HSK 120/M10 B BG	17003.2	61	PTKS-ADH 4/SI 6,3x32 OG	27090.3	15	SAP 16/2A BG	17254.2	40
HSK 120/M10 B/B BG	17007.2	61	Q			SAP 16/2A GN	17254.1	40, 41
HSK 120/M12 B BG	17004.2	61	QS 2 HSK 35/M6-M8	17028.2	60, 61	SDB 0,5x3,0	1085.0	14, 15, 36
HSK 16/M5 B BG	17000.2	60	QS 2/120/10	17014.0	61	SDB 0,6x3,5	1086.0	22, 23, 24, 25, 26, 27, 37, 38
HSK 35/M6 B BG	17001.2	60	QS 2/120/10	17241.0	70	SDB 0,8x4,0	1087.0	39, 40, 51
HSK 35/M6 B/B BG	17005.2	61	QS 2/120/12	17016.0	61	SDB 1,2x6,5	1088.0	41
HSK 50/M8 B BG	17002.2	60	QS 2/16	17008.0	60	SES 35 BG	17250.2	36, 37, 38, 39, 40, 41
HSK 50/M8 B/B BG	17006.2	61	QS 2/185/12	17243.0	71	SHES 35 BG	17259.2	42, 43
HSKG 120/M10/B/B BG	17023.2	70	QS 2/300/16	17245.0	71			
HSKG 185/M12/B/B BG	17024.2	71	QS 2/35	17010.0	60, 61	SMAG 10/6 BG	17122.2	39
HSKG 300/M16/B/B BG	17027.2	71	QS 2/35/6	17276.0	70	SMAG 16/6 BG	17135.2	40, 41
HSKG 35/M6/B/B BG	17170.2	70	QS 2/50	17012.0	60, 61	SMAG 35/6 BG	17148.2	41
HSKG 70/M8/B/B BG	17035.2	70	QS 2/70/8	17269.0	70	SMAG 4/2,5 BG	17120.2	37
I			QS 3 HSK 35/M6-M10/2	17029.2	60, 61			
ISKS 5	2818.0	41, 42, 50						

Type	Cat. no.	Page	Type	Cat. no.	Page	Type	Cat. no.	Page
SMAG 6/4 BG	17121.2	38	SRK 16/2A/IS BU	17126.5	40	TK 4/2/F OG	1152.3	27
SQ 120/2	17278.0	43	SRK 16/2A/Z BG	17125.2	40	TK 4/3 BG	1143.2	26
SQ 120/3	17279.0	43	SRK 16/2A/Z/IS BG	17127.2	40	TK 4/3 OG	1143.3	26
SQ 120/4	17280.0	43	SRK 2,5/2A BG	17100.2	36	TK 4/3/F BG	1153.2	27
SQ 50/2	17255.0	42	SRK 2,5/2A BK	17100.4	36	TK 4/3/F OG	1153.3	27
SQ 50/3	17256.0	42	SRK 2,5/2A BU	17100.5	36	TK 4/4 BG	1144.2	26
SQ 50/4	17257.0	42	SRK 2,5/2A GN	17100.1	36	TK 4/4 OG	1144.3	26
SQ 70/2	17265.0	42	SRK 2,5/2A GR	17100.6	36	TK 4/4/F BG	1154.2	27
SQ 70/3	17266.0	42	SRK 2,5/2A OG	17100.3	36	TK 4/4/F OG	1154.3	27
SQ 70/4	17267.0	42	SRK 2,5/2A RD	17100.9	36	TK 4/5 BG	1145.2	26
SQI 10/10 YE	17239.8	39	SRK 2,5/2A SAS BG	17119.2	36	TK 4/5 OG	1145.3	26
SQI 10/2 YE	17231.8	39	SRK 2,5/2A WH	17100.7	36	TK 4/5/F BG	1155.2	27
SQI 10/3 YE	17232.8	39	SRK 2,5/2A YE	17100.8	36	TK 4/5/F OG	1155.3	27
SQI 10/30 YE	17240.8	39	SRK 35/2A BG	17140.2	41	TK 4/6 BG	1146.2	26
SQI 10/4 YE	17233.8	39	SRK 35/2A BU	17140.5	41	TK 4/6 OG	1146.3	26
SQI 10/5 YE	17234.8	39	SRK 35/2A/IS BG	17142.2	41	TK 4/6/F BG	1156.2	27
SQI 10/6 YE	17235.8	39	SRK 35/2A/IS BU	17142.5	41	TK 4/6/F OG	1156.3	27
SQI 10/7 YE	17236.8	39	SRK 35/2A/Z BG	17141.2	41	TK 4/7 BG	1147.2	26
SQI 10/8 YE	17237.8	39	SRK 35/2A/Z/IS BG	17143.2	41	TK 4/7 OG	1147.3	26
SQI 10/9 YE	17238.8	39	SRK 4/2A BG	17104.2	37	TK 4/7/F BG	1157.2	27
SQI 16/2 YE	17247.8	40,	SRK 4/2A BK	17104.4	37	TK 4/7/F OG	1157.3	27
		41	SRK 4/2A BU	17104.5	37	TK 4/8 BG	1148.2	26
SQI 2,5/10 YE	17209.8	36	SRK 4/2A GN	17104.1	37	TK 4/8 OG	1148.3	26
SQI 2,5/2 YE	17201.8	36	SRK 4/2A GR	17104.6	37	TK 4/8/F BG	1158.2	27
SQI 2,5/3 YE	17202.8	36	SRK 4/2A OG	17104.3	37	TK 4/8/F OG	1158.3	27
SQI 2,5/30 YE	17210.8	36	SRK 4/2A RD	17104.9	37	TK 4/9 BG	1149.2	26
SQI 2,5/4 YE	17203.8	36	SRK 4/2A SAS BG	17116.2	37	TK 4/9 OG	1149.3	26
SQI 2,5/5 YE	17204.8	36	SRK 4/2A WH	17104.7	37	TK 4/9/F BG	1159.2	27
SQI 2,5/6 YE	17205.8	36	SRK 4/2A YE	17104.8	37	TK 4/9/F OG	1159.3	27
SQI 2,5/7 YE	17206.8	36	SRK 50/2A BG	17156.2	42	TK 4/SI 5x20 BG	1139.2	27
SQI 2,5/8 YE	17207.8	36	SRK 50/2A BU	17156.5	42	TK 4/SI 5x20 OG	1139.3	27
SQI 2,5/9 YE	17208.8	36	SRK 6/2A BG	17108.2	38	TK 4/SI 5x25 BG	1140.2	27
SQI 35/2 YE	17252.8	41	SRK 6/2A BK	17108.4	38	TK 4/SI 5x25 OG	1140.3	27
SQI 4/10 YE	17219.8	37	SRK 6/2A BU	17108.5	38	TKS 10/1 GR	17032.6	24
SQI 4/2 YE	17211.8	37	SRK 6/2A GN	17108.1	38	TKS 10/1 OG	17032.3	24
SQI 4/3 YE	17212.8	37	SRK 6/2A GR	17108.6	38	TKS 10/2 GR	17033.6	24
SQI 4/30 YE	17220.8	37	SRK 6/2A OG	17108.3	38	TKS 10/2 OG	17033.3	24
SQI 4/4 YE	17213.8	37	SRK 6/2A RD	17108.9	38	TKS 10/3 GR	17046.6	24
SQI 4/5 YE	17214.8	37	SRK 6/2A SAS BG	17117.2	38	TKS 10/3 OG	17046.3	24
SQI 4/6 YE	17215.8	37	SRK 6/2A WH	17108.7	38	TKS 16/2 GR	17193.6	25
SQI 4/7 YE	17216.8	37	SRK 6/2A YE	17108.8	38	TKS 16/2 OG	17193.3	25
SQI 4/8 YE	17217.8	37	SRK 70/2A BG	17161.2	42	TKS 4/1 GR	1222.6	22
SQI 4/9 YE	17218.8	37	SRK 70/2A BU	17161.5	42	TKS 4/1 OG	1222.3	22
SQI 6/10 YE	17229.8	38	SSL 10/2A GNYE	17115.2	39	TKS 4/1/F GR	1225.6	23
SQI 6/2 YE	17221.8	38	SSL 16/2A GNYE	17130.2	40	TKS 4/1/F OG	1225.3	23
SQI 6/3 YE	17222.8	38	SSL 16/2A/IS GNYE	17131.2	41	TKS 4/2 GR	1223.6	22
SQI 6/30 YE	17230.8	38	SSL 2,5/2A GNYE	17103.2	36	TKS 4/2 OG	1223.3	22
SQI 6/4 YE	17223.8	38	SSL 35/2A GNYE	17145.2	41	TKS 4/2/F GR	1226.6	23
SQI 6/5 YE	17224.8	38	SSL 35/2A/IS GNYE	17147.2	41	TKS 4/2/F OG	1226.3	23
SQI 6/6 YE	17225.8	38	SSL 4/2A GNYE	17107.2	37	TKS 4/3 GR	1224.6	22
SQI 6/7 YE	17226.8	38	SSL 50/2A GNYE	17158.2	42	TKS 4/3 OG	1224.3	22
SQI 6/8 YE	17227.8	38	SSL 6/2A GNYE	17111.2	38	TKS 4/3/F GR	1227.6	23
SQI 6/9 YE	17228.8	38	SSL 70/2A GNYE	17163.2	43	TKS 4/3/F OG	1227.3	23
SQIK 2,5-10 YE	17200.8	36,				TKS 4/SI 5x20 GR	17030.6	25
		37,	T			TKS 4/SI 5x20 OG	17030.3	25
		38,	TK 10 BG	1138.2	27	TKS 4/SI 5x25 GR	17047.6	25
		39	TK 10 OG	1138.3	27	TKS 4/SI 5x25 OG	17047.3	25
SRK 10/2A BG	17112.2	39	TK 10/ZP BG	1161.2	27	TKS 4/SI 6,3x32 GR	17031.6	25
SRK 10/2A BK	17112.4	39	TK 10/ZP OG	1161.3	27	TKS 4/SI 6,3x32 OG	17031.3	25
SRK 10/2A BU	17112.5	39	TK 4/1 BG	1141.2	26	TW 16-120 BG	17018.2	60,
SRK 10/2A GN	17112.1	39	TK 4/1 OG	1141.3	26			61
SRK 10/2A GR	17112.6	39	TK 4/1 YE/GN	1136.8	26	TW 2,5-10 BG	2002.2	36,
SRK 10/2A OG	17112.3	39	TK 4/1/F BG	1151.2	27			37,
SRK 10/2A RD	17112.9	39	TK 4/1/F OG	1151.3	27			38,
SRK 10/2A SAS BG	17118.2	39	TK 4/10 BG	1150.2	26			39
SRK 10/2A WH	17112.7	39	TK 4/10 OG	1150.3	26	TW 35-120/B/B BG	17022.2	61
SRK 10/2A YE	17112.8	39	TK 4/10/F BG	1160.2	27			
SRK 120/2A BG	17165.2	43	TK 4/10/F OG	1160.3	27			
SRK 120/2A BU	17165.5	43	TK 4/2 BG	1142.2	26			
SRK 16/2A BG	17124.2	40	TK 4/2 OG	1142.3	26			
SRK 16/2A BU	17124.5	40	TK 4/2/F BG	1152.2	27			
SRK 16/2A/IS BG	17126.2	40						

Types and catalogue numbers, *numeric*

Cat. no.	Type	Page	Cat. no.	Type	Page	Cat. no.	Type	Page
1						3		
1085.0	SDB 0,5x3,0	14, 15, 36	1154.2	TK 4/4/F BG	27	3327.7	PMC SB 7,5/40 So WH	14, 22, 23, 24, 25, 26, 27
1086.0	SDB 0,6x3,5	22, 23, 24, 25, 26, 27, 37, 38	1154.3	TK 4/4/F OG	27			
1087.0	SDB 0,8x4,0	39, 40, 51	1155.2	TK 4/5/F BG	27			
1088.0	SDB 1,2x6,5	41	1155.3	TK 4/5/F OG	27			
1120.2	RK 50 BG	50	1156.2	TK 4/6/F BG	27			
1120.4	RK 50 BK	50	1156.3	TK 4/6/F OG	27			
1120.5	RK 50 BU	50	1157.2	TK 4/7/F BG	27			
1120.6	RK 50 GR	50	1157.3	TK 4/7/F OG	27			
1121.2	MAG 50 BG	42, 43, 50, 51	1158.2	TK 4/8/F BG	27			
1122.2	RK 95 BG	50	1158.3	TK 4/8/F OG	27			
1122.4	RK 95 BK	50	1159.2	TK 4/9/F BG	27			
1122.5	RK 95 BU	50	1159.3	TK 4/9/F OG	27			
1122.6	RK 95 GR	50	1160.2	TK 4/10/F BG	27			
1123.2	MAG 95 BG	50, 51	1160.3	TK 4/10/F OG	27			
1124.2	RK 150 BG	50	1161.2	TK 10/ZP BG	27			
1124.4	RK 150 BK	50	1161.3	TK 10/ZP OG	27			
1124.5	RK 150 BU	50	1222.3	TKS 4/1 OG	22			
1124.6	RK 150 GR	50	1222.6	TKS 4/1 GR	22			
1125.2	MAG 150/240 BG	50, 51	1223.3	TKS 4/2 OG	22			
1126.2	RK 240 BG	51	1223.6	TKS 4/2 GR	22			
1126.4	RK 240 BK	51	1224.3	TKS 4/3 OG	22			
1126.5	RK 240 BU	51	1224.6	TKS 4/3 GR	22			
1126.6	RK 240 GR	51	1225.3	TKS 4/1/F OG	23			
1136.8	TK 4/1 YE/GN	26	1225.6	TKS 4/1/F GR	23			
1138.2	TK 10 BG	27	1226.3	TKS 4/2/F OG	23			
1138.3	TK 10 OG	27	1226.6	TKS 4/2/F GR	23			
1139.2	TK 4/SI 5x20 BG	27	1227.3	TKS 4/3/F OG	23			
1139.3	TK 4/SI 5x20 OG	27	1227.6	TKS 4/3/F GR	23			
1140.2	TK 4/SI 5x25 BG	27						
1140.3	TK 4/SI 5x25 OG	27	2					
1141.2	TK 4/1 BG	26	2001.1	AP 2,5-10 GN	38, 39			
1141.3	TK 4/1 OG	26	2001.2	AP 2,5-10 BG	36, 37, 38, 39			
1142.2	TK 4/2 BG	26	2002.2	TW 2,5-10 BG	36, 37, 38, 39			
1142.3	TK 4/2 OG	26	2274.0	EP 50	42, 43, 50, 51			
1143.2	TK 4/3 BG	26	2275.0	EP 95	43, 50, 51			
1143.3	TK 4/3 OG	26	2277.0	EP 150	50, 51			
1144.2	TK 4/4 BG	26	2360.0	EP 240	51			
1144.3	TK 4/4 OG	26	2763.2	AQI 2/50 YE	50			
1145.2	TK 4/5 BG	26	2764.2	AQI 3/50 YE	50			
1145.3	TK 4/5 OG	26	2765.2	AQI 2/95 YE	50			
1146.2	TK 4/6 BG	26	2766.2	AQI 3/95 YE	50			
1146.3	TK 4/6 OG	26	2767.2	AQI 2/150 YE	50			
1147.2	TK 4/7 BG	26	2768.2	AQI 3/150 YE	50			
1147.3	TK 4/7 OG	26	2770.2	AQI 3/240 YE	51			
1148.2	TK 4/8 BG	26	2772.0	ISKS 6	42, 43, 50			
1148.3	TK 4/8 OG	26	2773.0	ISKS 8	50, 51			
1149.2	TK 4/9 BG	26	2804.0	AD 1/95/B YE	50			
1149.3	TK 4/9 OG	26	2806.0	AD 1/150/B YE	50			
1150.2	TK 4/10 BG	26	2808.0	AD 1/240/B YE	51			
1150.3	TK 4/10 OG	26	2810.0	AD 1/50/B YE	50			
1151.2	TK 4/1/F BG	27	2818.0	ISKS 5	41, 42, 50			
1151.3	TK 4/1/F OG	27	2828.0	ES 35/K/ST BG	50, 51, 60, 61, 70, 71			
1152.2	TK 4/2/F BG	27						
1152.3	TK 4/2/F OG	27						
1153.2	TK 4/3/F BG	27						
1153.3	TK 4/3/F OG	27						
						4		
						4600.7	PMC SB 5/50 WH	36
						4702.7	PMC SB 6/50 WH	37, 50, 51, 60, 61, 70, 71
						9		
						9323.7	PMC SB 8/40 WH	38, 39, 40, 41, 42, 43
						9326.7	PMC SB 7,5/40 WH	14, 22, 23, 24, 25, 26, 27
						17		
						17000.2	HSK 16/M5 B BG	60
						17001.2	HSK 35/M6 B BG	60
						17002.2	HSK 50/M8 B BG	60
						17003.2	HSK 120/M10 B BG	61
						17004.2	HSK 120/M12 B BG	61
						17005.2	HSK 35/M6 B/B BG	61
						17006.2	HSK 50/M8 B/B BG	61
						17007.2	HSK 120/M10 B/B BG	61
						17008.0	QS 2/16	60
						17009.0	QS 3/16	60
						17010.0	QS 2/35	60, 61
						17011.0	QS 3/35	60, 61
						17012.0	QS 2/50	60, 61
						17013.0	QS 3/50	60, 61
						17014.0	QS 2/120/10	61
						17015.0	QS 3/120/10	61
						17016.0	QS 2/120/12	61
						17017.0	QS 3/120/12	61
						17018.2	TW 16-120 BG	60, 61
						17019.8	AD 16 YE	60
						17020.8	AD 35 YE	60, 61
						17021.8	AD 50 YE	60, 61
						17022.2	TW 35-120/B/B BG	61
						17023.2	HSKG 120/M10/B/B BG	70
						17024.2	HSKG 185/M12/B/B BG	71
						17025.2	ADH 120 BG	70
						17025.5	ADH 120 BU	70
						17025.8	ADH 120 YE	70
						17026.8	AD 120 YE	61
						17027.2	HSKG 300/M16/B/B BG	71
						17028.2	QS 2 HSK 35/M6-M8	60, 61
						17029.2	QS 3 HSK 35/M6-M10/2	60, 61

Notes



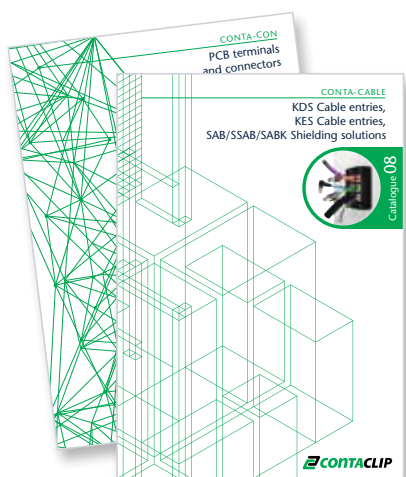

Our products for your challenges:

- 01** **CONTA-CONNECT**
Terminal blocks
with Push-in connection system
Cat. no. 98070.2
- 02** **CONTA-CONNECT**
Terminal blocks with Screw connection system
and special purpose terminals
Cat. no. 98071.2
- 03** **CONTA-CONNECT**
Terminal blocks
with Tension-spring connection system
Cat. no. 98072.2
- 04** **CONTA-CONNECT**
Installation materials and
other accessories for terminal blocks
Cat. no. 98073.2
- 05** **CONTA-LABEL**
Marking components
for thermal transfer marking systems
Cat. no. 98074.2
- 06** **CONTA-LABEL**
Marking components
for ink-based marking systems
Cat. no. 98075.2
- 07** **CONTA-BOX**
Housings
Cat. no. 98076.2
- 08** **CONTA-CABLE**
KDS Cable entries, KES Cable entries,
SAB/SSAB/SABK Shielding solutions
Cat. no. 98077.2
- 09** **CONTA-ELECTRONICS**
Electrical and electronic
cabinet components
Cat. no. 98078.2
- 10** **CONTA-CON**
PCB terminal and connectors
Cat. no. 98079.2