

CABINET AIR CONDITIONER

Widely used in outdoor communication cabinets, battery cabinets, electrical cabinets, industrial control cabinets, and other environmental spaces that require heat dissipation





Semi-embedded Mounting

Side Mounting



Characteristic

- Multiple automatic protection and comprehensive fault self-diagnosis;
- Exquisite craftsmanship and high-quality international brand accessories ensure more stable and reliable products;
- Suitable for T3 high-temperature working conditions and R134a environmentally friendly refrigerant;
- Equipped with RS485 interface as standard, achieving telemetry, remote signaling, and remote adjustment;
- LED Nixie tube display, field parameters can be set;
- Standard heating function, optional hydrogen discharge function;
- Dry contact alarm output, normally open/normally closed optional

SPECIFICATION

Model	LK004AS	LK006AS	LK010AS	LK015AS	LK020AS	LK030AS	LK050AS
Power Supply	230VAC±15% 50Hz/60Hz						
Cooling Capacity	400W @L35/L35	600W @L35/L35	1000W @L35/L35	1500W @L35/L35	2000W @L35/L35	3000W @L35/L35	5000W @L35/L35
Power Consumption	190W @L35/L35	260W @L35/L35	440W @L35/L35	650W @L35/L35	750W @L35/L35	1430W @L35/L35	2000W @L35/L35
Semi-embedded Mounting Dimensions mm (With flange)	H480xW355xD178	H580xW350xD175	H780xW480xD200	H780xW480xD200	H780xW480xD200	H1200xW535xD225	H1350xW650xD300
Side Mounting Dimensions mm (With flange)	—	H550xW320xD175	H750xW450xD200	H750xW450xD200	H750xW450xD200	—	—
IP Grade	IP55						
Refrigerant	R134a						
Net Weight	14kg	15kg	31kg	31kg	34kg	50kg	100kg
Surface Treatment	RAL7035						

Outdoor power industry cabinet air conditioner(600~5000W)



IP55 CE

Characteristic

- Multiple automatic protection and comprehensive fault self-diagnosis
- Exquisite craftsmanship and high-quality international brand accessories ensure more stable and reliable products
- Suitable for T3 high-temperature working conditions and R134a environmentally friendly refrigerant
- Equipped with RS485 interface as standard, achieving telemetry, remote signaling, and remote adjustment
- LED Nixie tube display, field parameters can be set
- Standard heating function, optional hydrogen discharge function
- Standard dehumidification function
- Dry contact alarm output, normally open/normally closed optional
- 4-20mA temperature and humidity signal output function

SPECIFICATION

Model	LK006AD	LK010AD	LK015AD	LK020AD	LK030AD	LK050AD
Power Supply	230VAC±15% 50Hz/60Hz					
Cooling Capacity	600W@L35/L35	1000W@L35/L35	1500W@L35/L35	2000W@L35/L35	3000W@L35/L35	5000W@L35/L35
Power Consumption	300W@L35/L35	440W@L35/L35	650W@L35/L35	870W@L35/L35	1430W@L35/L35	2000W@L35/L35
Semi-embedded Mounting Dimensions mm (With flange)	H580xW350xD175	/	/	/	/	/
Side Mounting Dimensions mm (With flange)	/	H795xW495xD195	H795xW495xD195	H795xW495xD195	H1350xW550xD300	H1400xW670xD300
IP Grade	IP55					
Refrigerant	R134a					
Net Weight	15kg	30kg	39kg	41kg	50kg	100kg
Surface Treatment	RAL7035					

Indoor general cabinet air conditioner(300~4000W)



Side Mounting

IP54 CE

Characteristic

- Multiple automatic protection and comprehensive fault self-diagnosis
- Exquisite craftsmanship and high-quality international brand accessories ensure more stable and reliable products
- Suitable for T3 high-temperature working conditions and R134a environmentally friendly refrigerant
- Equipped with RS485 interface as standard, achieving telemetry, remote signaling, and remote adjustment
- LED Nixie tube display, field parameters can be set
- Standard heating function, optional hydrogen discharge function
- Standard dehumidification function
- Dry contact alarm output, normally open/normally closed optional
- Built-in condensate evaporator

SPECIFICATION

Model	LK003AF	LK005AF	LK008AF	LK010AF	LK015AF	LK015AFH	LK020AF	LK030AF	LK040AF
Power Supply	230VAC±15% 50Hz/60Hz								
Cooling Capacity	300W@L35/L35	500W@L35/L35	800W@L35/L35	1000W@L35/L35	1500W@L35/L35	1500W@L35/L35	2000W@L35/L35	3000W@L35/L35	4000W@L35/L35
Power Consumption	180W@L35/L35	210W@L35/L35	345W@L35/L35	600W@L35/L35	650W@L35/L35	650W@L35/L35	870W@L35/L35	1430W@L35/L35	1800W@L35/L35
Side Mounting Dimensions mm (Without flange)	H580x W280xD175	H580x W280xD175	H580x W370xD175	H950x W400xD210	H950x W400xD210	H1105x W405xD220	H1105x W405xD220	H1580x W400xD270	H1580x W400xD270
IP Grade	IP54								
Refrigerant	R134a								
Net Weight	14kg	15kg	20kg	34kg	36kg	38kg	40kg	65kg	68kg
Surface Treatment	RAL7035								



Semi-embedded Mounting

Side Mounting

IP55 CE

Characteristic

- The design of the upper air outlet structure ensures a longer air supply distance and better matches the air duct design;
- High air volume to improve the temperature uniformity of the battery environment;
- Standard dehumidification function;
- Standard RS485 interface for telemetry, remote signaling, and remote adjustment;
- Optional internal fan speed control, more energy-efficient;
- Optional C5 high anti-corrosion configuration;
- Optional explosion-proof configuration;

SPECIFICATION

Model	LK020AE	LK030AE	LK050AE	LK075AE	LK125AE	LK150AE	LK200AE	LK250AE
Power Supply	230VAC±15% 50Hz/60Hz			1~,220VAC 50Hz	3~,380-415VAC 50Hz			
Cooling Capacity	2000W	3000W	5000W	7500W	12500W	15000W	20000W	25000W
Power Consumption	840W	1430W	2000W	2700W	4000W	6000W	8500W	12500W
Semi-embedded (With flange) Dimensions mm	H833x W483xD216	H1350x W550xD300	H1450x W670xD300	H2100x W800xD906	/	/	/	/
Side Mounting (With flange) Dimensions mm	/	/	/	/	H2100x W800xD906	H2100x W800xD906	H2100x W800xD906	H2100x W800xD906
IP Grade	IP55						IPX5	IPX5
Refrigerant	R134A			R410A				
Net Weight	37kg	50kg	100kg	75kg	210kg	220kg	230kg	255kg
Surface Treatment	RAL7035							



Semi-embedded Mounting

IP55 **CE**

Characteristic

- This product is widely used in applications that require constant temperature control, such as battery cabinets, electrical cabinets, industrial control cabinets, etc;
- Multiple automatic protections and comprehensive fault self diagnosis;
- Exquisite craftsmanship and high-quality international brand accessories ensure that products are more stable and reliable;
- R134a environmentally friendly refrigerant;
- Standard RS485 interface for telemetry, remote signaling, and remote adjustment;
- LED digital display, on-site parameters can be set;
- Dry contact alarm output, normally open/normally closed optional;
- Refrigeration output PID regulation, temperature control accuracy $\leq \pm 0.5\text{ }^{\circ}\text{C}$

SPECIFICATION

Model	LK010AJ	LK015AJ	LK020AJ
Power Supply	230VAC \pm 15% 50Hz/60Hz		
Cooling Capacity	1000W@L35/L35	1500W@L35/L35	2000W@L35/L35
Power Consumption	450W@L35/L35	650W@L35/L35	870W@L35/L35
Semi-embedded Dimensions mm	H795xW495xD175	H795xW495xD175	H795xW495xD175
IP Grade	IP55		
Refrigerant	R134A		
Net Weight	38kg	40kg	42kg
Surface Treatment	RAL7035		

INDOOR CEILING MOUNTED INDUSTRIAL AIR-COOLED AIR CONDITIONER

Indoor power industry cabinet air conditioner(1000~1500W)



Top Mounting

IP44 CE

Characteristic

- This product is widely used in indoor machine tools, electrical cabinets, industrial control cabinets and other occasions that require heat dissipation;
- Multiple automatic protections and comprehensive fault self diagnosis;
- Exquisite craftsmanship and high-quality international brand accessories ensure that products are more stable and reliable;
- R134a environmentally friendly refrigerant;
- Standard RS485 interface for telemetry, remote signaling, and remote adjustment;
- LED digital display, on-site parameters can be set;
- Heating function and dehumidification function are optional;
- Dry contact alarm output, normally open/normally closed optional;
- Built in condensate evaporator;

SPECIFICATION

Model	LK010ANT	LK015ANT
Power Supply	220VAC±15% 50Hz	
Cooling Capacity	1000W	1500W
Power Consumption	440W	700W
Top Mounting Dimensions mm	H450xW450xD350	H450xW450xD350
IP Grade	IP44	
Refrigerant	R134A	
Net Weight	30kg	32kg
Surface Treatment	RAL7035	

Indoor general cabinet air conditioner(500~2000W)



Semi-embedded Mounting

IP55 CE

Characteristic

- Efficient rotor DC variable frequency compressor and fan: reliable and energy-saving;
- Intelligent communication: RS485 communication port and dry contact alarm output port, convenient for remote monitoring;
- Digital tube display: on-site parameters can be set and display the operating status inside the cabinet;
- High protection level: perfect for outdoor use;
- Easy to maintain design: reduces maintenance difficulty;
- Wide operating temperature range: reliable operation under all environmental conditions;
- Heating function is optional;

SPECIFICATION

Model	LK006DS1	LK010DS1	LK015DS1	LK020DS1
Power Supply	48VDC(DC44-59V)			
Cooling Capacity	500W@L35/L35	1000W@L35/L35	1500W@L35/L35	2000W@L35/L35
Power Consumption	180W@L35/L35	295W@L35/L35	495W@L35/L35	710W@L35/L35
Semi-embedded Dimensions mm	H315xW546xD175	H446xW746xD200	H446xW746xD200	H446xW746xD200
IP Grade	IP55			
Refrigerant	R134A			
Net Weight	14kg	28kg	29kg	30kg
Surface Treatment	RAL7035			



Side Mounting

Cooling mode

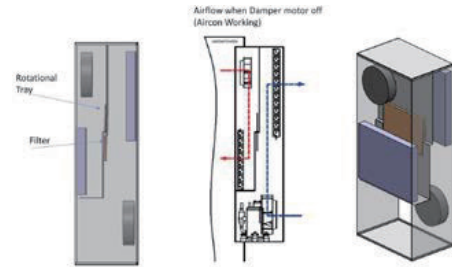

Fresh air mode

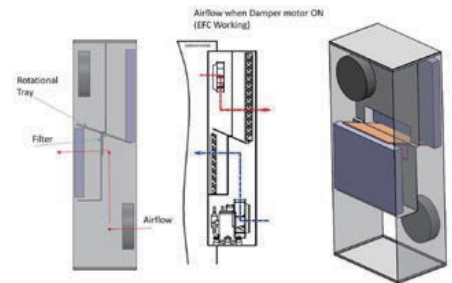

IP44 CE

Characteristic

- Multiple automatic protection and comprehensive fault self diagnosis function;
- Exquisite craftsmanship and high-quality international brand accessories ensure that products are more stable and reliable;
- Suitable for T3 high-temperature working conditions and R134a environmentally friendly refrigerant;
- Standard RS485 interface for telemetry, remote signaling, and remote adjustment;
- LED digital display, on-site parameters can be set;
- Built in fresh air system, capable of intelligently selecting modes based on ambient temperature, more energy-efficient;
- Dry contact alarm output, normally open/normally closed optional;

SPECIFICATION

Model	LK015DS2	LK020DS2
Power Supply	-48VDC	
Cooling Capacity	1500W@L35/L35	2000W@L35/L35
Power Consumption	395W@L35/L35	405W@L35/L35
Side Mounting Dimensions mm	H1000xW412xD275	H1000xW412xD275
IP Grade	IP44	
Refrigerant	R134A	
Net Weight	45kg	46kg
Surface Treatment	RAL7035	



Side Mounting



Operating principle

This series of water heat exchangers is widely used to cool the air inside various electrical cabinets, ensuring reliable operation of electrical components at safe temperatures and extending their service life.

Suitable for various control boxes, distribution cabinets, and other electrical devices with high temperature and humidity requirements in industries such as machinery, electricity, chemical engineering, instrumentation, and textiles.

SPECIFICATION

Model	LK010ANU	LK010AN	LK020ANU	LK020AN	LK030ANU	LK030AN	LK040ANU	LK040AN
Power Supply	110VAC±15% 50Hz/60Hz	1N~230VAC 50Hz/60Hz	110VAC±15% 50Hz/60Hz	1N~230VAC 50Hz/60Hz	110VAC±15% 50Hz/60Hz	1N~230VAC 50Hz/60Hz	110VAC±15% 50Hz/60Hz	1N~230VAC 50Hz/60Hz
Cooling Capacity	1000W	1000W	2000W	2000W	3000W	3000W	4000W	4000W
Power Consumption	79W	79W	122W	122W	122W	122W	172W	172W
Side Mounting Dimensions mm	H530x W300xD140	H530x W300xD140	H950x W400xD145	H950x W400xD145	H950x W400xD145	H950x W400xD145	H857x W455xD226	H857x W455xD226
Temperature range	18-50°C							
Water supply	≥7L/min	≥7L/min	≥7L/min	≥7L/min	≥13L/min	≥13L/min	≥15L/min	≥15L/min
Net Weight	8kg	8kg	17kg	17kg	18kg	18kg	20kg	20kg
Surface Treatment	RAL7035							

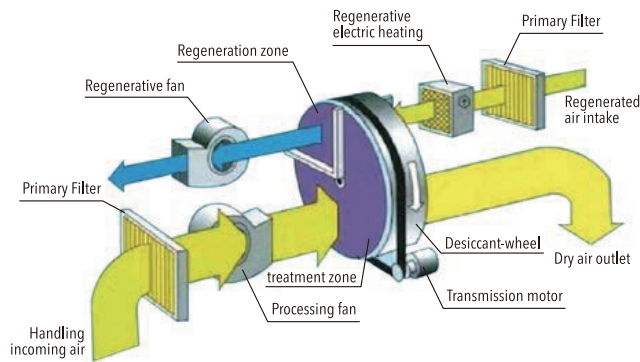

Operating principle

The rotary dehumidifier uses silica gel coated on the rotary wheel to physically adsorb moisture from the air onto the porous synthetic silica gel. Then, in the regeneration zone of the rotary wheel, the water vapor in the adsorbed silica gel pores is heated and vaporized, and sent to the inlet of the AC heat exchanger to form high-temperature and high humidity air. After passing through the heat exchanger that has been cooled by indoor cold and humid air, condensed water is discharged due to dew point differences.

SPECIFICATION

Model	LKH/001
Mounting type	Landing&Wall Mounted
Power Supply	220VAC 50Hz/60Hz
Dehumidification capacity	395W @L35/L35
Power Consumption	high-grade 3L/D (30°C 80 RH), Low end 1.5L/D (30°C 80 RH)
Work Temperature	-15°C~+55°C
Max Noise Level	41dB(A)
Net Weight	6kg
Dimensions	H410XW255XD150 (mm)
Communication method	Optional RS485 communication interface



Industrial air Conditioner

Characteristic

- Complete internal and external isolation, dust prevention, oil mist prevention, moisture prevention, etc
- Compact structure, compatible with mainstream models in the industry -15~+55°C flexible setting
- Professional condensate treatment design, effectively solve the problem of condensate discharge
- Nano coating, strong corrosion resistance
- Optional smoke detector, access control and water immersion alarm
- Dust screen plug design, convenient and fast replacement
7X24X365 has been running continuously for more than 10 years
- LCD Chinese and English menu display,
- Support MODBUS communication, with call start function

IP54

CE

-15 +55
°C

SPECIFICATION

Model	Unit	EIA05
Height/Width/Depth	mm	550x280x210
Quality	kg	<17
Installation method external		External hanging (side mounted)
Scope of working environment	°C	-15 ~ +55
Noise level	dB(A)	65
Protection level/cryogen		IP54
Cryogen		R134a
Cooling capacity @ I35/I35	W	500-550
Input power @ I35/I35	W	260-280
Input current @ I35/I35	A	1.3-1.35
Rated voltage, frequency	V, Hz	1~ ,220,50/60

DIMENSION (mm)

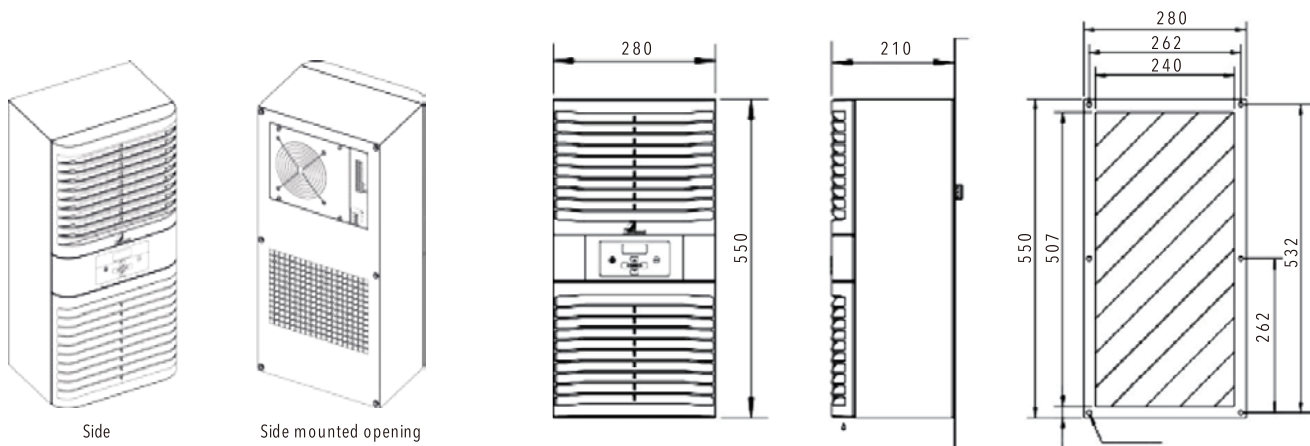



Industrial air Conditioner

Characteristic

- Complete internal and external isolation, dust prevention, oil mist prevention, moisture prevention, etc
- Compact structure, compatible with mainstream models in the industry -15~+55°C flexible setting
- Professional condensate treatment design, effectively solve the problem of condensate discharge
- Nano coating, strong corrosion resistance
- Optional smoke detector, access control and water immersion alarm
- Dust screen plug design, convenient and fast replacement
- 7X24X365 has been running continuously for more than 10 years
- LCD Chinese and English menu display,
- Support MODBUS communication, with call start function

IP54

CE

-15 ~ +55
°C

SPECIFICATION

Model	Unit	EIA10	EIA15	EIA20
Height/Width/Depth	mm	950x400x280	950x400x280	950x400x280
Quality	kg	<41	<41	<41
Installation method external				
Scope of working environment	°C	-15 ~ +55	-15 ~ +55	-15 ~ +55
Noise level	dB(A)	65	65	65
Protection level/cryogen		IP54 R134a	IP54 R134a	IP54 R134a
Cooling capacity @ I35/I35	W	1100/1300	1500/1700	2000/2100
Input power @ I35/I35	W	540/680	750/900	1000/1200
Input current @ I35/I35	A	2.5/3.2	3.5/4.2	4.6/5.7
Rated voltage, frequency	V, Hz	1~, 220, 50/60	1~, 220, 50/60	1~, 220, 50/60

DIMENSION (mm)

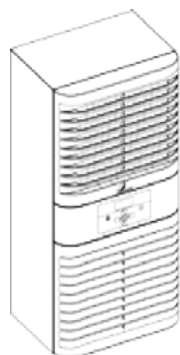

Side

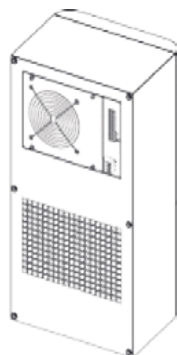

Side mounted opening

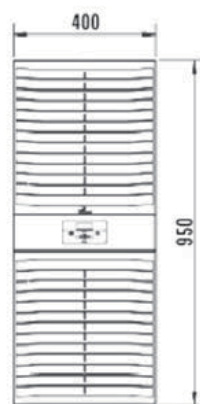



Industrial air Conditioner Characteristic

- Complete internal and external isolation, dust prevention, oil mist prevention, moisture prevention, etc
- Compact structure, compatible with mainstream models in the industry -15~+55°C flexible setting
- Professional condensate treatment design, effectively solve the problem of condensate discharge
- Nano coating, strong corrosion resistance
- Optional smoke detector, access control and water immersion alarm
- Dust screen plug design, convenient and fast replacement
- 7X24X365 has been running continuously for more than 10 years
- LCD Chinese and English menu display,
- Support MODBUS communication, with call start function

IP54

CE

-15 +55
°C

SPECIFICATION

Model	Unit	EIA40
Height/Width/Depth	mm	1580x500x340
quality	kg	89
Installation method	External	Side/door mounted
Scope of working environment	°C	-15~+55
Noise level	dB(A)	65
Protection level		IP54
Refrigerant		R134a
Cooling capacity @ L35/L35	W	4000/4500
Input power @ L35/L35	W	1900/2600
Input current @ L35/L35	A	3.1/4.2
Rated voltage, frequency	V, Hz	3~ ,380,50/60
Air switch	P,A	3,10

DIMENSION (mm)

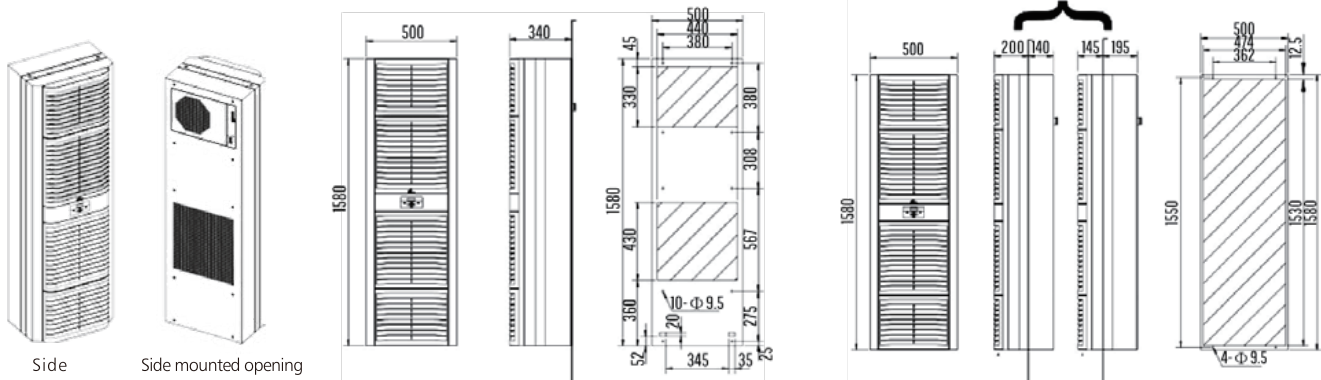

Side

Side mounted opening