

# ASS-T Multi-tone alarm sounder

- 94 mm cubic-design multi-tone alarm sounder
- Max. 108 dB (A) sound pressure
- High degree of protection IP 66
- Optional mounting type using metal bracket
- 32 tones can be selected, 3 tones can be switched externally

- Sound pressure infinitely adjustable by potentiometer
- For industrial and general applications
- Combinations of multi-tone alarm sounders and beacons available

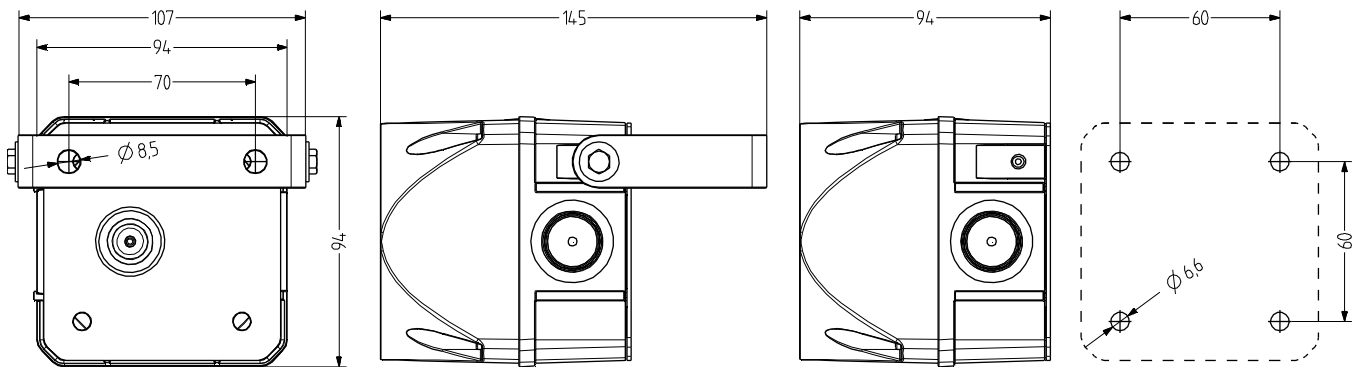

## TECHNICAL DATA

Housing	Polycarbonate red (RAL 3000)
Type of mounting	any, Sound outlet opening at bottom or horizontal
Cable entry	Back: Grommet 5-10 mm Side: AKV cable gland M20 × 1.5 7-14 mm can be mounted
Connection technology	Screw/plug-in terminal up to 2,5 mm <sup>2</sup>
Leakage current	0,003 A
Tone	32 Tones, 3 Tones can be switched externally, see tone table

Volume	108 dB (can be adjusted with potentiometer)
Tone frequency	150-2.900 Hz
Duty cycle	100 %
Operating temperature	-30 °C / +60 °C
Degree of protection	IP66 & UL Type 4/4x/13
Impact resistance	IK09
Weight	300 g

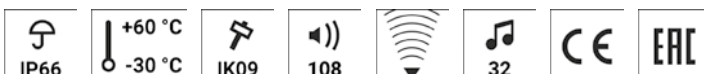

# ASS-T

## ORDER DATA

Nominal voltage	Voltage range (V)	Nominal current (A)	Mains frequency	Order number
24-48 V AC/DC	21-53 V AC 21-60 V DC	0,230	50-60 Hz	874 170 408
110-240 V AC	95-265	0,070	50-60 Hz	874 170 313



AMK



AB1



AG1



AKV



AW1

## ACCESSORIES

Type	Type of accessory	Weight	Order number
AMK	Mounting set for combining several pieces of signalling equipment of the same size	10 g	874 010 900
AB1	Mounting set for metal bracket for mounting in any direction (e.g. on mounting platforms)		874 031 900
AG1	Flat seal for correct IP66 installation on smooth surfaces		874 021 900
AKV	Cable gland M20x1,5		698 800 026
AW1	Stainless steel bracket		874 041 900

## TONE TABLE

STAGE 1 S1	Tone type	Frequency Hz	Pictogram	Repeat rate	Specific application	ASS-T/ADS-T				STAGE 2 S2	STAGE 3 S3
						max dB	max dB ADS-T	max dB	max dB		
	Tone 01 continuous	660 Hz			Swedish alarm	103	107	114	116	tone 16	tone 12
	Tone 02 continuous	1000 Hz			PFEER toxic gas	97	110	113	121	tone 16	tone 25
	Tone 03 continuous	2400 Hz				106	111	120	125	tone 21	tone 17
	Tone 04 intermittent	420 Hz		0,625 s on / 0,625 s off	Australian alert AS1670	98	106	109	117	tone 21	tone 01
	Tone 05 intermittent	660 Hz		1,8 s on - 1,8 s off	Swedish alarm	103	107	114	117	tone 21	tone 01
	Tone 06 intermittent	660 Hz		0,15 s on / 0,15 s off	Swedish alarm	103	107	114	117	tone 16	tone 01
	Tone 07 intermittent	970 Hz		1 s on, 1 sec off	PFEER Alarm, BS5839-1:2002	99	111	113	122	tone 18	tone 01
	Tone 08 intermittent	970 Hz (950)		0,5 s on/0,5 s off x 3 then 1 s off	ISO 8201 low tone, US Temporal	101	111	113	122	tone 16	tone 03
	Tone 09 intermittent	800 Hz		0,25 s on / 1 s off		108	112	112	124	tone 27	tone 03
	Tone 10 intermittent	700 Hz		0,15 s on / 0,15 s off, total 1 min.	Swedish alarm SS 031711	102	110	112	119	tone 18	tone 02
	Tone 11 intermittent	720 Hz		0,7 s on / 0,3 s off	Industrial Alarm Germany	102	110	111	123	tone 02	tone 29
	Tone 12 intermittent	2400 Hz		0,5 s on / 0,5 s off		106	111	120	126	tone 03	tone 01
	Tone 13 intermittent	2850 Hz		0,5 s on/0,5 s off x 3 then 1 s off	ISO 8201 high tone, US Temporal	97	108	111	120	tone 03	tone 17
	Tone 14 alternating	440 - 554 Hz		0,4 s (440Hz) / 0,1 s (554Hz)	AFNOR France, NFS 32-001	103	109	109	118	tone 16	tone 01
	Tone 15 alternating	554 - 440 Hz		1 Hz	Swedish alarm	103	109	109	118	tone 01	tone 16
	Tone 16 alternating	800 - 1000 Hz		2 Hz		108	113	113	121	tone 02	tone 09
	Tone 17 alternating	2400 - 2900 Hz		2 Hz		106	111	120	126	tone 03	tone 01
	Tone 18 alternating	1000 - 2000 Hz		1 Hz	Singapore	107	110	120	127	tone 02	tone 03
	Tone 19 sweeping	500 - 1500 Hz		10 Hz		108	113	119	124	tone 02	tone 01
	Tone 20 sweeping	150 - 1000 Hz		rising 10 s, 40 s on, falling 10 s	Industrial Alarm Germany	108	113	114	123	tone 25	tone 29
	Tone 21 continuous	400 Hz		simulated horn		101	106	109	115	tone 16	tone 02
	Tone 22 sweeping	500 - 1200 Hz		rising in 3,75 s / 0,25 s off	Australian evacuation AS 2220	108	113	117	124	tone 02	tone 09
	Tone 23 sweeping	500 - 1200 Hz		rising in 3,5 s / 0,5 s off	Netherlands NEN 2575:2000	108	113	117	124	tone 02	tone 09
	Tone 24 sweeping	500 - 1200 Hz		0,5 s on/0,5 s off x 3 / 1,5 s off	Australia AS1670 evacuation	108	113	117	124	tone 02	tone 09
	Tone 25 sweeping	1200 - 500 Hz		1 Hz	evacuation Germany, DIN 33404-3	108	113	117	124	tone 02	tone 32
	Tone 26 sweeping	500 - 1200 Hz		0,3 Hz		108	113	117	124	tone 01	tone 32
	Tone 27 sweeping	1400 - 1600 Hz		rising in 1 s/falling in 0,5 s	NFC 48-265	102	110	119	124	tone 02	tone 09
	Tone 28 sweeping	2400 - 2900 Hz		1 Hz		106	111	120	126	tone 17	tone 03
	Tone 29 bell					102	108	120	122	tone 16	tone 02
	Tone 30 slow rise	500 - 2400 Hz		siren rising in 3 s, then cont. 2400 Hz		108	113	120	127	tone 16	tone 01
	Tone 31 slow rise	300 - 1200 Hz		siren rising in 3 s, then cont. 1200 Hz		108	113	117	124	tone 16	tone 01
	Tone 32 3-tone gong	660-550-440 Hz		repeating 3-tone gong, 7s		90	93	X	X	tone 29	tone 01
	Tone 32 chime	970 - 800 Hz		repeating ding-dong, 1 Hz		X	X	113	123	tone 29	tone 01



Electronic