

Tolleranze generali

Particolari stampati in materiale termoplastico: rif ISO 2768MK - Particolari lavorati alle macchine utensili: rif. UNI EN 22768
 Particolari tranciati in metallo: rif. UNI EN 22768 - grado IT10 per dim. lineari - grado IT11 quote di piega - angoli di piega ± 1

ACCESSORI/ACCESSORIES

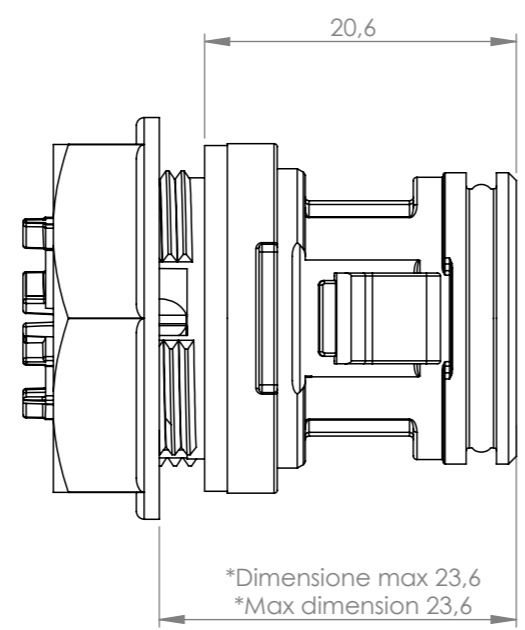
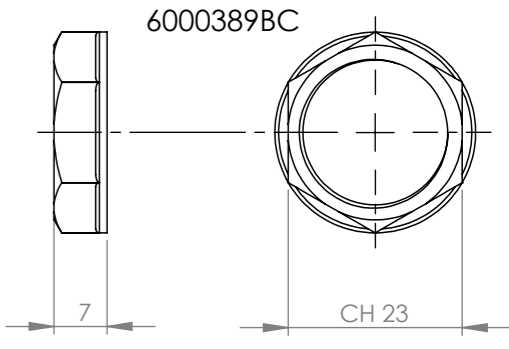

*= Dimensione con pannello max 3mm
 Max dimension with panel 3mm

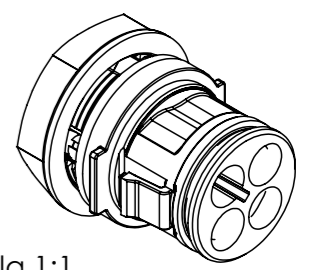
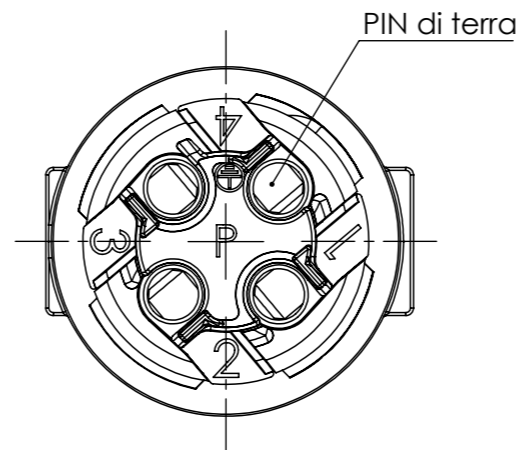
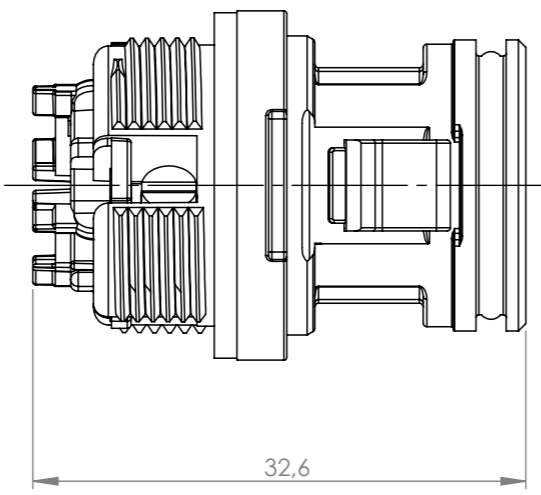
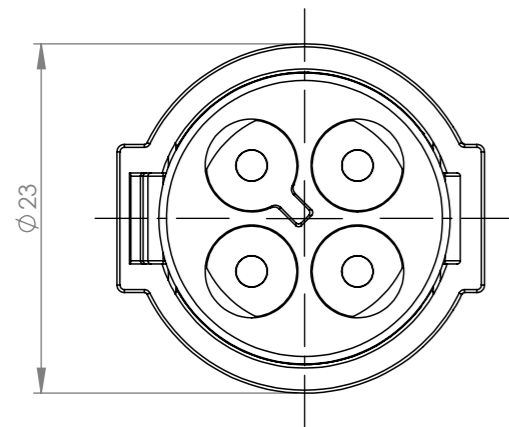

Scala 1:1

Questo disegno è proprietà esclusiva di Techno e non può essere copiato, ristampato, o comunque utilizzato senza permesso scritto dalla Techno srl. This drawing and all informations contained here can not be used or reproduced, integrally or partially, without Techno srl written authorization.	Materiale-Material:		Titolo-Title:			
	Trattamento-Treatment:		Plug 4P a pannello UP			
	N° documento cliente Customer ref	Peso [gr]: Weight [gr]:	15.97	Progetto-Project:		
	Disegnato - Drawn by: E.Negroni	Data: 2023-02-15	Scala-Scale: 2:1	TH389		
Controllato-Checked by: M.Strada	Data: 2023-03-01	Formato - Format A3	N° Disegno - Drawing N° THB.389.S4EU			
				Rev. 00	Foglio N° 1	N° Fogli 1
				Nome file - Filename THB.389.S4EU		