

# QUINT-PS/1AC/24DC/ 3.5 - Power supply



2866747

<https://www.phoenixcontact.com/au/products/2866747>

Please be informed that the data shown in this PDF document is generated from our online catalog. Please find the complete data in the user documentation. Our general terms of use for downloads are valid.



Primary-switched power supply unit QUINT POWER, Screw connection, SFB Technology (Selective Fuse Breaking), input: 1-phase, output: 24 V DC / 3.5 A

## Product description

QUINT POWER power supplies with maximum functionality

QUINT POWER circuit breakers magnetically and therefore quickly trip at six times the nominal current, for selective and therefore cost-effective system protection. The high level of system availability is additionally ensured, thanks to preventive function monitoring, as it reports critical operating states before errors occur.

Reliable starting of heavy loads takes place via the static power reserve POWER BOOST. Thanks to the adjustable voltage, all ranges between 5 V DC ... 56 V DC are covered.

## Your advantages

- Reliable starting of difficult loads with the static POWER BOOST power reserve with up to 1.5 times the nominal current permanently
- Fast tripping of standard circuit breakers with dynamic power reserve SFB (selective fuse breaking) technology with up to 6 times the nominal current for 12 ms
- For superior system availability
- Preventive function monitoring

## Commercial data

Item number	2866747
Packing unit	1 pc
Minimum order quantity	1 pc
Sales key	CMPQ13
Product key	CMPQ13
Catalog page	Page 242 (C-4-2019)
GTIN	4046356113779
Weight per piece (including packing)	874.5 g
Weight per piece (excluding packing)	546 g
Customs tariff number	85044095
Country of origin	TH

## Technical data

### Input data

#### AC operation

Nominal input voltage range	100 V AC ... 240 V AC
Input voltage range	85 V AC ... 264 V AC
	90 V DC ... 350 V DC
Input voltage range AC	85 V AC ... 264 V AC
Input voltage range DC	90 V DC ... 350 V DC
Electric strength, max.	300 V AC
Voltage type of supply voltage	AC/DC
Inrush current	< 20 A (typical)
Inrush current integral ( $I^2t$ )	< 2 A <sup>2</sup> s
AC frequency range	45 Hz ... 65 Hz
Frequency range DC	0 Hz
Mains buffering time	typ. 20 ms (120 V AC)
	typ. 80 ms (230 V AC)
Current consumption	1.4 A (120 V AC)
	0.8 A (230 V AC)
	0.9 A (110 V DC)
	0.4 A (220 V DC)
Nominal power consumption	180 VA
Protective circuit	Transient surge protection; Varistor
Typical response time	< 0.05 s
Input fuse	5 A (slow-blow, internal)
Permissible backup fuse	B6 B10 B16 AC:
Permissible DC backup fuse	DC: Connect a suitable fuse upstream
Recommended breaker for input protection	6 A ... 20 A (AC: Characteristics B, C, D, K)
Discharge current to PE	< 3.5 mA

### Output data

Efficiency	> 88 % (for 230 V AC and nominal values)
Output characteristic	U/I
Nominal output voltage	24 V DC $\pm$ 1 %
Setting range of the output voltage ( $U_{Set}$ )	18 V DC ... 29.5 V DC (> 24 V DC, constant capacity restricted)
Nominal output current ( $I_N$ )	3.5 A (-25 °C ... 60 °C, $U_{OUT}$ = 24 V DC)
POWER BOOST ( $I_{Boost}$ )	4 A (-25 °C ... 40 °C permanent, $U_{OUT}$ = 24 V DC )
Selective Fuse Breaking ( $I_{SFB}$ )	15 A (12 ms)
Magnetic circuit breaker tripping	B2
Derating	60 °C ... 70 °C (2.5 %/K)
Feedback voltage resistance	$\leq$ 35 V DC
Protection against overvoltage at the output (OVP)	$\leq$ 35 V DC
	< 1 % (change in load, static 10 % ... 90 %)

# QUINT-PS/1AC/24DC/ 3.5 - Power supply



2866747

<https://www.phoenixcontact.com/au/products/2866747>

Control deviation	< 2 % (change in load, dynamic 10 % ... 90 %)
	< 0.1 % (change in input voltage $\pm 10$ %)
Residual ripple	< 50 mV <sub>PP</sub> (with nominal values)
Output power	84 W
Maximum no-load power dissipation	3.5 W
Power loss nominal load max.	11 W
Rise time	< 0.04 s ( $U_{OUT}$ (10 % ... 90 %))
Connection in parallel	yes, for redundancy and increased capacity
Connection in series	yes

Signal: DC OK active

Output description	$U_{OUT} > 0.9 \times U_N$ : High signal
Switching voltage range	18 V DC ... 24 V DC
Maximum inrush current	$\leq 20$ mA (short-circuit-proof)
Continuous load current	$\leq 20$ mA

Signal: DC OK floating

Output description	Relay contact, $U_{OUT} > 0.9 \times U_N$ : Contact closed
Maximum switching voltage	30 V AC/DC
	24 V DC
Maximum inrush current	0.5 A
	1 A
Continuous load current	$\leq 1$ A

Signal: POWER BOOST, active

Output description	$I_{OUT} < I_N$ : High signal
Switching voltage range	18 V DC ... 24 V DC
Output voltage	+ 24 V DC
Maximum inrush current	$\leq 20$ mA (short-circuit-proof)
Continuous load current	$\leq 20$ mA

## Connection data

Input

Connection method	Screw connection
Conductor cross section, rigid min.	0.2 mm <sup>2</sup>
Conductor cross section, rigid max.	2.5 mm <sup>2</sup>
Conductor cross section flexible min.	0.2 mm <sup>2</sup>
Conductor cross section flexible max.	2.5 mm <sup>2</sup>
Conductor cross section AWG min.	20
Conductor cross section AWG max.	12
Stripping length	7 mm
Screw thread	M3
Tightening torque, min	0.5 Nm
Tightening torque max	0.6 Nm

# QUINT-PS/1AC/24DC/ 3.5 - Power supply



2866747

<https://www.phoenixcontact.com/au/products/2866747>

## Output

Connection method	Screw connection
Conductor cross section, rigid min.	0.2 mm <sup>2</sup>
Conductor cross section, rigid max.	2.5 mm <sup>2</sup>
Conductor cross section flexible min.	0.2 mm <sup>2</sup>
Conductor cross section flexible max.	2.5 mm <sup>2</sup>
Conductor cross section AWG min.	20
Conductor cross section AWG max.	12
Stripping length	7 mm
Screw thread	M3
Tightening torque, min	0.5 Nm
Tightening torque max	0.6 Nm

## Signal

Connection method	Pluggable screw connection
Conductor cross section, rigid min.	0.2 mm <sup>2</sup>
Conductor cross section, rigid max.	2.5 mm <sup>2</sup>
Conductor cross section flexible min.	0.2 mm <sup>2</sup>
Conductor cross section flexible max.	2.5 mm <sup>2</sup>
Conductor cross section AWG min.	20
Conductor cross section AWG max.	12
Screw thread	M3
Tightening torque, min	0.5 Nm
Tightening torque max	0.6 Nm

## Signaling

Types of signaling	LED
	Active switching output
	Relay contact
Operating voltage display	Green LED

### Signal output: DC OK active

Status display	$U_{OUT} > 0.9 \times U_N$ : "DC OK" LED green
Note on status display	$U_{OUT} < 0.9 \times U_N$ : Flashing "DC OK" LED
	$I_{OUT} < I_N$ : LED ON

### Signal output: DC OK floating

Status display	$U_{OUT} > 0.9 \times U_N$ : "DC OK" LED green
Note on status display	$U_{OUT} < 0.9 \times U_N$ : Flashing "DC OK" LED

### Signal output: POWER BOOST, active

Status display	$I_{OUT} > I_N$ : LED "BOOST" yellow
----------------	--------------------------------------

## Electrical properties

Number of phases	1
------------------	---

# QUINT-PS/1AC/24DC/ 3.5 - Power supply



2866747

<https://www.phoenixcontact.com/au/products/2866747>

Insulation voltage input/output	4 kV AC (type test)
	2 kV AC (routine test)
Insulation voltage output / PE	500 V DC (routine test)
Insulation voltage input / PE	3.5 kV AC (type test)
	2 kV AC (routine test)

## Product properties

Product type	Power supply
Product family	QUINT POWER
MTBF (IEC 61709, SN 29500)	> 1433000 h (25 °C)
	> 820000 h (40 °C)
	> 360000 h (60 °C)

## Insulation characteristics

Protection class	I
Degree of pollution	2

## Dimensions

Width	32 mm
Height	130 mm
Depth	125 mm

## Installation dimensions

Installation distance right/left	5 mm / 5 mm
Installation distance top/bottom	50 mm / 50 mm

## Alternative assembly

Width	122 mm
Height	130 mm
Depth	35 mm

## Mounting

Assembly note	alignable: $P_N \geq 50\%$ , 5 mm horizontally, 15 mm next to active components, 50 mm vertically alignable: $P_N < 50\%$ , 0 mm horizontally, 40 mm vertically top, 20 mm vertically bottom
Mounting position	horizontal DIN rail NS 35, EN 60715
With protective coating	no

## Material specifications

Housing material	Metal
Hood version	Galvanized sheet steel, free from chrome (VI)
Side element version	Aluminum

## Environmental and real-life conditions

### Ambient conditions

# QUINT-PS/1AC/24DC/ 3.5 - Power supply



2866747

<https://www.phoenixcontact.com/au/products/2866747>

Degree of protection	IP20
Ambient temperature (operation)	-25 °C ... 70 °C (> 60 °C Derating: 2,5 %/K)
Ambient temperature (storage/transport)	-40 °C ... 85 °C
Maximum altitude	5000 m
Climatic class	3K3 (in acc. with EN 60721)
Max. permissible relative humidity (operation)	≤ 95 % (at 25 °C, non-condensing)
Shock	18 ms, 30g, in each space direction (according to IEC 60068-2-27)
Vibration (operation)	< 15 Hz, amplitude ±2.5 mm (according to IEC 60068-2-6) 15 Hz ... 150 Hz, 2.3g, 90 min.
Temp code	T3C (-25 ... +60 °C)

## Standards and regulations

Rail applications	EN 50121-4
Standard – Limitation of mains harmonic currents	EN 61000-3-2
Standard - Electrical safety	IEC 61010-2-201 (SELV)
Standard - Equipment safety	BG (design tested)
Standard - Approval for medical use	IEC 60601-1, 2 x MOOP
Standard – Protection against shock currents, basic requirements for protective separation in electrical equipment	EN 50178
Standard – Safety extra-low voltage	IEC 61010-1 (SELV) IEC 61010-2-201 (PELV)
Standard - Safe isolation	IEC 61010-2-201
Standard - safety for equipment for measurement, control, and laboratory use	IEC 61010-1
Approval - requirement of the semiconductor industry with regard to mains voltage dips	SEMI F47-0706 Compliance Certificate
DeviceNet approval	DeviceNet™ Power Supply Conformance Tested

## Overvoltage category

EN 62477-1	III
------------	-----

## Approvals

CSA	CAN/CSA-C22.2 No. 60950-1-07 CSA-C22.2 No. 107.1-01
Shipbuilding approval	DNV GL (EMC A), ABS, LR, RINA, NK, BV
UL approvals	UL Listed UL 508 UL/C-UL Recognized UL 60950-1 UL ANSI/ISA-12.12.01 Class I, Division 2, Groups A, B, C, D T3C (Hazardous Location)
DeviceNet approval	DeviceNet™ Power Supply Conformance Tested

## EMC data

Electromagnetic compatibility	Conformance with EMC Directive 2014/30/EU
Low Voltage Directive	Conformance with Low Voltage Directive 2014/35/EC
EMC requirements for noise emission	EN 61000-6-3

# QUINT-PS/1AC/24DC/ 3.5 - Power supply



2866747

<https://www.phoenixcontact.com/au/products/2866747>

	EN 61000-6-4
EMC requirements for noise immunity	EN 61000-6-1
	EN 61000-6-2

## Noise emission

Standards/regulations	EN 55011 (EN 55022)
-----------------------	---------------------

## Electrostatic discharge

Standards/regulations	EN 61000-4-2
-----------------------	--------------

## Electrostatic discharge

Contact discharge	8 kV (Test Level 4)
Discharge in air	8 kV (Test Level 3)
Comments	Criterion A

## Electromagnetic HF field

Standards/regulations	EN 61000-4-3
-----------------------	--------------

## Electromagnetic HF field

Frequency range	80 MHz ... 1 GHz
Test field strength	20 V/m (Test Level 3)
Frequency range	1 GHz ... 2 GHz
Test field strength	10 V/m (Test Level 3)
Frequency range	2 GHz ... 3 GHz
Test field strength	10 V/m (Test Level 3)
Comments	Criterion A

## Fast transients (burst)

Standards/regulations	EN 61000-4-4
-----------------------	--------------

## Fast transients (burst)

Input	4 kV (Test Level 4 - asymmetrical)
Output	2 kV (Test Level 3 - asymmetrical)
Signal	2 kV (Test Level 4 - asymmetrical)
Comments	Criterion A

## Surge voltage load (surge)

Standards/regulations	EN 61000-4-5
-----------------------	--------------

## Surge voltage load (surge)

Input	2 kV (Test Level 3 - symmetrical)
	4 kV (Test Level 4 - asymmetrical)
Output	1 kV (Test Level 2 - symmetrical)
	2 kV (Test Level 3 - asymmetrical)
Signal	1 kV (Test Level 2 - asymmetrical)
Comments	Criterion A

## Conducted interference

# QUINT-PS/1AC/24DC/ 3.5 - Power supply



2866747

<https://www.phoenixcontact.com/au/products/2866747>

Standards/regulations	EN 61000-4-6
-----------------------	--------------

## Conducted interference

Input/output/signal	asymmetrical
Frequency range	0.15 MHz ... 80 MHz
Comments	Criterion A
Voltage	10 V (Test Level 3)

## Emitted interference

Standards/regulations	EN 61000-6-3
Radio interference voltage in acc. with EN 55011	EN 55011 (EN 55022) Class B, area of application: Industry and residential
Emitted radio interference in acc. with EN 55011	EN 55011 (EN 55022) Class B, area of application: Industry and residential

## Criteria

Criterion A	Normal operating behavior within the specified limits.
Criterion B	Temporary impairment to operational behavior that is corrected by the device itself.



# QUINT-PS/1AC/24DC/ 3.5 - Power supply

2866747

<https://www.phoenixcontact.com/au/products/2866747>

## Drawings

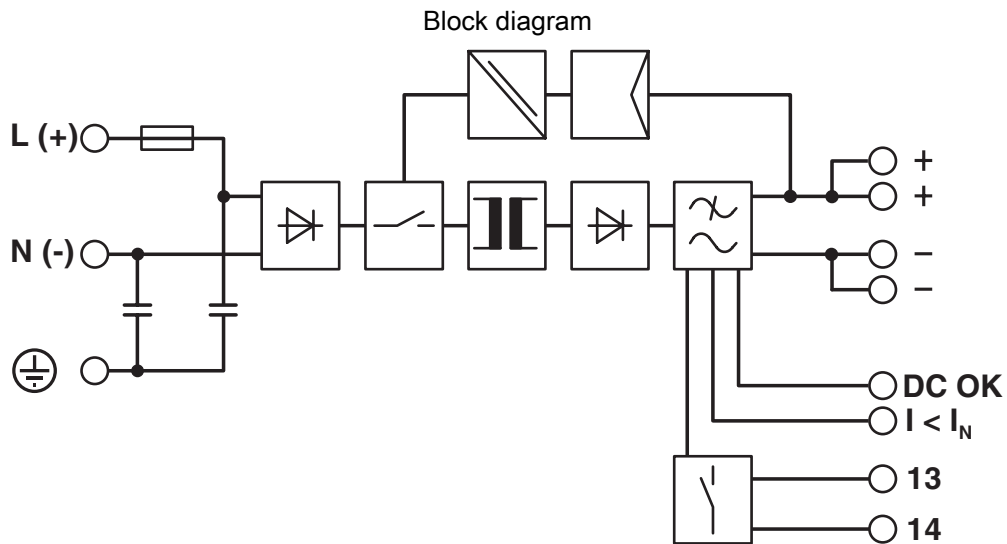

# QUINT-PS/1AC/24DC/ 3.5 - Power supply



2866747

<https://www.phoenixcontact.com/au/products/2866747>

## Approvals

To download certificates, visit the product detail page: <https://www.phoenixcontact.com/au/products/2866747>



**cUL Recognized**  
Approval ID: E211944



**UL Recognized**  
Approval ID: E211944



**IECEE CB Scheme**  
Approval ID: SI-1865 A2



**EAC**  
Approval ID: EAC-Zulassung



**LR**  
Approval ID: LR22301698TA-02



**NK**  
Approval ID: TA24091M



**BV**  
Approval ID: 21004/C1 BV



**EAC**  
Approval ID: RU S-DE.BL08.W.00764



**UL Listed**  
Approval ID: E123528



**cUL Listed**  
Approval ID: E123528



**RINA**  
Approval ID: ELE333522XG

# QUINT-PS/1AC/24DC/ 3.5 - Power supply



2866747

<https://www.phoenixcontact.com/au/products/2866747>

## ABS

Approval ID: 23-2355407-PDA

## DeviceNet™

## DeviceNet™

Approval ID: 10824/06.01.2010

## SEMI F47

Approval ID: SEMI F47



## EAC

Approval ID: RU S-DE.BL08.W.00764

## DNV

Approval ID: TAA000030X



## cCSAus

Approval ID: 1897767



## cUL Listed

Approval ID: E199827



## UL Listed

Approval ID: E199827

# QUINT-PS/1AC/24DC/ 3.5 - Power supply



2866747

<https://www.phoenixcontact.com/au/products/2866747>

## Classifications

### ECLASS

ECLASS-13.0

27040701

### ETIM

ETIM 9.0

EC002540

### UNSPSC

UNSPSC 21.0

39121000

# QUINT-PS/1AC/24DC/ 3.5 - Power supply



2866747

<https://www.phoenixcontact.com/au/products/2866747>

## Environmental product compliance

### EU RoHS

Fulfills EU RoHS substance requirements	Yes
Exemption	7(a), 7(c)-I

### China RoHS

Environment friendly use period (EFUP)	EFUP-25
	An article-related China RoHS declaration table can be found in the download area for the respective article under "Manufacturer declaration". For all articles with EFUP-E, no China RoHS declaration table issued and required.

### EU REACH SVHC

REACH candidate substance (CAS No.)	Lead(CAS: 7439-92-1)
SCIP	6af20dc9-de89-42ab-aaf1-351dcffa637b

### EF3.0 Climate Change

CO2e kg	21.45 kg CO2e
---------	---------------

Phoenix Contact 2025 © - all rights reserved  
<https://www.phoenixcontact.com>

PHOENIX CONTACT PTY Ltd  
Unit 7, 2-8 South Street  
Rydalmere NSW 2116  
1300 786 411  
[customerservice@phoenixcontact.com.au](mailto:customerservice@phoenixcontact.com.au)