

AXL E EIP DIO16 M12 6P - Digital module



2701494

<https://www.phoenixcontact.com/au/products/2701494>

Please be informed that the data shown in this PDF document is generated from our online catalog. Please find the complete data in the user documentation. Our general terms of use for downloads are valid.



Axioline E, Digital I/O device, EtherNet/IP™, M12 connector, Digital inputs: 16, 24 V DC, connection technology: 4-conductor, Digital outputs: 16, 24 V DC, connection technology: 3-conductor, Plastic housing, degree of protection: IP65/IP67

Product description

The Axioline E device is designed for use within an EtherNet/IP™ network. It is used to acquire and output digital signals.

Your advantages

- Connection to EtherNet/IP™ network using M12 connectors (D-coded)
- Transmission speed of 10 Mbps and 100 Mbps
- Connection of digital sensors and actuators using M12connectors (A-coded)
- Diagnostic and status indicators
- Short-circuit and overload protection of the sensor supply
- IP65/IP67 degree of protection

Commercial data

Item number	2701494
Packing unit	1 pc
Minimum order quantity	1 pc
Sales key	DRI7DD
Product key	DRI7DD
Catalog page	Page 170 (C-6-2019)
GTIN	4046356763486
Weight per piece (including packing)	558.8 g
Weight per piece (excluding packing)	549.8 g
Customs tariff number	85176200
Country of origin	DE

AXL E EIP DIO16 M12 6P - Digital module



2701494

<https://www.phoenixcontact.com/au/products/2701494>

Technical data

Dimensions

Dimensional drawing	
Width	60 mm
Height	185 mm
Depth	30.5 mm
Drill hole spacing	198.5 mm
Note on dimensions	The height is 212 mm including fixing clips.

Notes

Note on application	
Note on application	Only for industrial use
Utilization restriction	
EMC note	EMC: class A product, see manufacturer's declaration in the download area

Material specifications

Housing material	Pocan®
Color	anthracite

Interfaces

EtherNet/IP™	
Number of interfaces	2
Connection method	M12 connector
Note on the connection method	D-coded
Number of positions	4
Transmission speed	10/100 Mbps (with auto negotiation)

EtherNet/IP™	
Equipment type	EtherNet/IP™ device
System-specific protocols	EtherNet/IP™ protocols ACD
	EtherNet/IP™ protocols DLR
	EtherNet/IP™ protocols IGMP v2
Protocols supported	SNMP v1
	HTTP
	TFTP

AXL E EIP DIO16 M12 6P - Digital module



2701494

<https://www.phoenixcontact.com/au/products/2701494>

Specification	FTP
	BootP
	DHCP
	CIP Edition 3.11 EIP adaptation of CIP 1.12

Input data

Digital:

Input name	Digital inputs
Description of the input	EN 61131-2 types 1 and 3
Number of inputs	16
Cable length	max. 30 m (to the sensor)
Connection method	M12 connector double occupancy
Connection technology	4-conductor
Input voltage range "0" signal	0 V DC ... 5 V DC
Input voltage range "1" signal	11 V DC ... 30 V DC
Nominal input voltage U_{IN}	24 V DC
Nominal input current at U_{IN}	typ. 3 mA
Sensor current per channel	typ. 75 mA (from U_S)
Total sensor current	max. 1.2 A (per device)
Input filter time	< 1000 μ s
Protective circuit	Overload protection, short-circuit protection of sensor supply

Output data

Digital:

Output name	Digital outputs
Connection method	M12 connector double occupancy
Connection technology	3-conductor
Number of outputs	16
Protective circuit	Overload protection, short-circuit protection of outputs; yes
Output voltage	24 V DC
Limitation of the voltage induced on circuit interruption	-28 V ... -17 V
Maximum output current per channel	500 mA
Nominal output voltage	24 V DC (from voltage U_S)
Output voltage range	18 V DC ... 31.2 V DC
Output voltage when switched off	max. 1 V
Output current when switched off	max. 20 μ A
Nominal load, inductive	12 VA (1.2 H, 48 Ω , with nominal voltage)
Nominal load, ohmic	12 W (48 Ω , with nominal voltage)
Switching frequency	max. 5500 per second (with at least 50 mA load current) max. 1 per second (with inductive load)
Reverse voltage resistance to short pulses	Reverse voltage proof
Behavior with overload	Auto restart

AXL E EIP DIO16 M12 6P - Digital module



2701494

<https://www.phoenixcontact.com/au/products/2701494>

Signal delay	max. 150 μ s (when switched on)
	max. 200 μ s (when switched off)
Overcurrent shut-down	min. 0.7 A

Product properties

Product type	I/O component
Product family	Axioline E
Type	Stand-Alone
Special properties	Plastic housing

Electrical properties

Potentials

Voltage supply U_S	24 V DC
Power supply at U_S	max. 4 A
Current consumption from U_S	typ. 8 mA
	max. 1.2 A

Supply: Module electronics, sensors, and actuators

Designation	Module electronics, sensors and actuators (U_S)
Connection method	M12 connector, T-coded
Number of positions	4
Supply voltage	24 V DC
Supply voltage range	18 V DC ... 31.2 V DC (including all tolerances, including ripple)
Current consumption	typ. 190 mA \pm 15 % (at 24 V DC)
	max. 12 A

Supply: Actuators

Designation	Supply of actuators (U_A) for additional devices
Connection method	M12 connector, T-coded
Number of positions	4
Supply voltage	24 V DC
Supply voltage range	18 V DC ... 31.2 V DC (including all tolerances, including ripple)
Current consumption	typ. 3 mA \pm 15 % (at 24 V DC)
	max. 12 A

Electrical isolation/isolation of the voltage ranges

Test voltage: 24 V supply (communications power/sensor supply, digital inputs/outputs)/bus connection (Ethernet 1)	500 V AC, 50 Hz, 1 min
Test voltage: 24 V supply (communications power/sensor supply, digital inputs/outputs)/bus connection (Ethernet 2)	500 V AC, 50 Hz, 1 min
Test voltage: 24 V supply (communications power/sensor supply, digital inputs/outputs)/FE	500 V AC, 50 Hz, 1 min
Test voltage: Bus connection (Ethernet 1)/FE	500 V AC, 50 Hz, 1 min
Test voltage: Bus connection (Ethernet 2)/FE	500 V AC, 50 Hz, 1 min
Test voltage: Bus connection (Ethernet 1)/bus connection (Ethernet 2)	500 V AC, 50 Hz, 1 min

AXL E EIP DIO16 M12 6P - Digital module



2701494

<https://www.phoenixcontact.com/au/products/2701494>

Test voltage: 24 V supply (actuator supply)/24 V supply (communications power and sensor supply, digital inputs/outputs)	500 V AC, 50 Hz, 1 min
Test voltage: 24 V supply (actuator supply)/bus connection (Ethernet 1)	500 V AC, 50 Hz, 1 min
Test voltage: 24 V supply (actuator supply)/bus connection (Ethernet 2)	500 V AC, 50 Hz, 1 min
Test voltage: 24 V supply (actuator supply)/FE	500 V AC, 50 Hz, 1 min

Connection data

Connection method	M12 connector
-------------------	---------------

Environmental and real-life conditions

Ambient conditions

Ambient temperature (operation)	-25 °C ... 60 °C
Degree of protection	IP65/IP67
Air pressure (operation)	70 kPa ... 106 kPa (up to 3000 m above sea level)
Air pressure (storage/transport)	70 kPa ... 106 kPa (up to 3000 m above sea level)
Ambient temperature (storage/transport)	-25 °C ... 85 °C
Permissible humidity (operation)	5 % ... 95 %
Permissible humidity (storage/transport)	5 % ... 95 %

Standards and regulations

Protection class	III (IEC 61140, EN 61140, VDE 0140-1)
------------------	---------------------------------------

AXL E EIP DIO16 M12 6P - Digital module



2701494

<https://www.phoenixcontact.com/au/products/2701494>

Drawings

Dimensional drawing

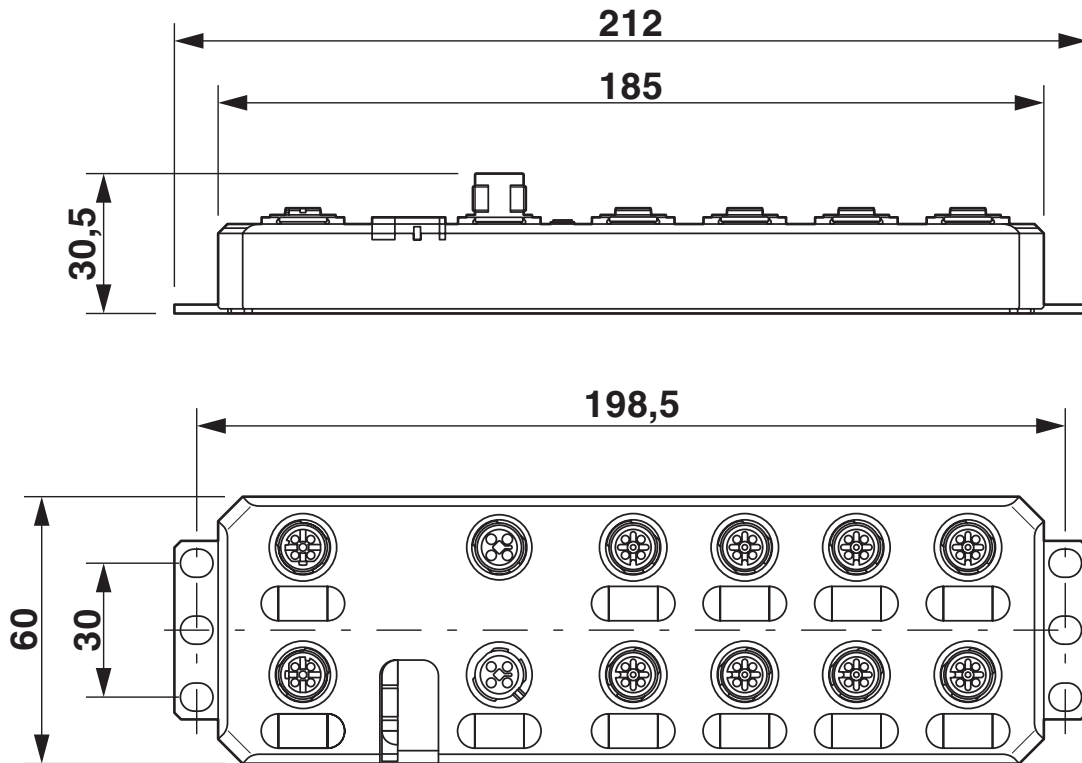

Dimensions (in mm)

Connection diagram

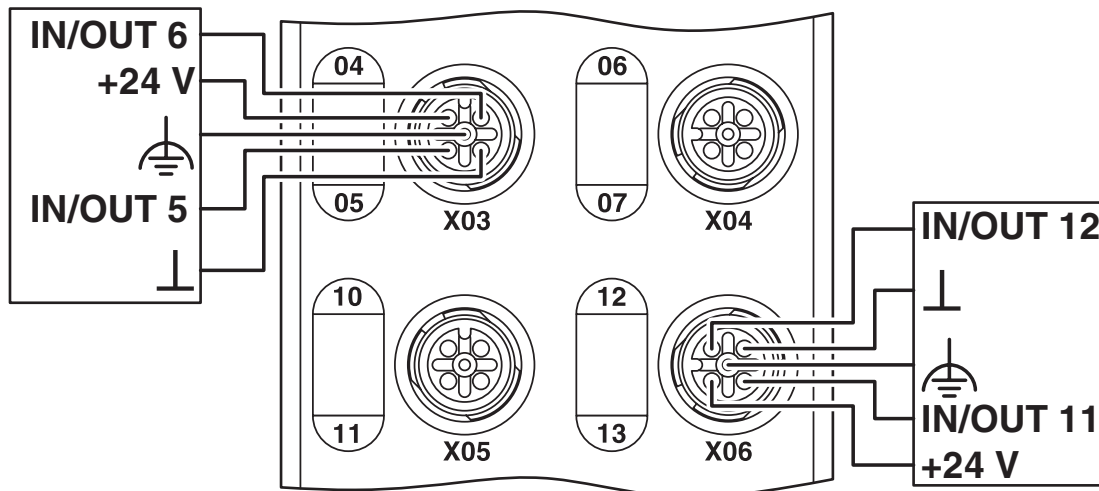

AXL E EIP DIO16 M12 6P - Digital module



2701494

<https://www.phoenixcontact.com/au/products/2701494>

Approvals

To download certificates, visit the product detail page: <https://www.phoenixcontact.com/au/products/2701494>

 **UL Listed**
Approval ID: E140324

 **cUL Listed**
Approval ID: E140324

EtherNet/IP conformance tested TM
Approval ID: 11145

 **cUL Listed**
Approval ID: E199827

 **UL Listed**
Approval ID: E199827

AXL E EIP DIO16 M12 6P - Digital module



2701494

<https://www.phoenixcontact.com/au/products/2701494>

Classifications

ECLASS

ECLASS-13.0

27242604

ETIM

ETIM 9.0

EC001599

UNSPSC

UNSPSC 21.0

32151600

2701494

<https://www.phoenixcontact.com/au/products/2701494>

Environmental product compliance

EU RoHS

Fulfills EU RoHS substance requirements	Yes
Exemption	6(c)

China RoHS

Environment friendly use period (EFUP)	EFUP-25
	An article-related China RoHS declaration table can be found in the download area for the respective article under "Manufacturer declaration". For all articles with EFUP-E, no China RoHS declaration table issued and required.

EU REACH SVHC

REACH candidate substance (CAS No.)	Lead(CAS: 7439-92-1)
SCIP	8678efcd-e0d9-4826-9466-80fab85121cc

Phoenix Contact 2025 © - all rights reserved

<https://www.phoenixcontact.com>

PHOENIX CONTACT PTY Ltd

Unit 7, 2-8 South Street

Rydalmere NSW 2116

1300 786 411

customerservice@phoenixcontact.com.au