

PSI-REP-PROFIBUS/12MB - Repeater



2708863

<https://www.phoenixcontact.com/au/products/2708863>

Please be informed that the data shown in this PDF document is generated from our online catalog. Please find the complete data in the user documentation. Our general terms of use for downloads are valid.



Modular repeater for electrical isolation and range increase for PROFIBUS up to 12 Mbps, 4-way isolation, rail-mountable, supply 24 V DC

Product description

The performance and availability of bus systems can be significantly increased by using repeaters. In addition to electrical isolation, bus segmentation with repeaters makes it possible to multiply the permissible coverage of the network and to extend the number of devices.

Your advantages

- Automatic data rate detection or fixed data rate setting via DIP switches
- Suitable for all data rates up to 12 Mbps
- High-quality 4-way isolation between all interfaces
- Bit oversampling for reliable detection of sporadic disturbances
- Bit retiming for unrestricted cascading of devices
- Filtering of faulty telegrams based on start delimiter detection
- Can be combined with PSI-MOS FO converters in a modular way thanks to DIN rail connectors

Commercial data

Item number	2708863
Packing unit	1 pc
Minimum order quantity	1 pc
Sales key	DNC121
Product key	DNC121
Catalog page	Page 422 (C-6-2019)
GTIN	4046356078993
Weight per piece (including packing)	232.3 g
Weight per piece (excluding packing)	212.4 g
Customs tariff number	85176200
Country of origin	DE

Technical data

Notes

Note on application

Note on application	Only for industrial use
---------------------	-------------------------

Utilization restriction

EMC note	EMC: class A product, see manufacturer's declaration in the download area
----------	---

Utilization restriction

CCCEX note	Use in potentially explosive areas is not permitted in China.
------------	---

Product properties

Product type	Interface converter
MTTF	1638 Years (SN 29500 standard, temperature 25°C, operating cycle 21%)
	812 Years (SN 29500 standard, temperature 40°C, operating cycle 34.25%)
	340 Years (SN 29500 standard, temperature 40°C, operating cycle 100%)
MTBF	1136 Years (Telcordia standard, 25°C temperature, 21% operating cycle (5 days a week, 8 hours a day))
	238 Years (Telcordia standard, 40°C temperature, 34.25% operating cycle (5 days a week, 12 hours a day))

Electrical properties

Electrical isolation	VCC // TBUS // PROFIBUS (A) // PROFIBUS (B)
Maximum power dissipation for nominal condition	2.16 W
Test voltage data interface/power supply	1.5 kV _{rms} (50 Hz, 1 min.)
Test voltage data interfaces	1.5 kV

Supply

Supply voltage range	18 V DC ... 30 V DC (via pluggable COMBICON screw terminal block)
Nominal supply voltage	24 V DC
Typical current consumption	< 90 mA (24 V DC ...)
Max. current consumption	≤ 2 A (For operation in a joining station, via the DIN rail connector)

Output data

Switching

Output name	Relay output
Output description	Alarm output
Number of outputs	1
	60 V DC (Resistive Load, General Load)

PSI-REP-PROFIBUS/12MB - Repeater



2708863

<https://www.phoenixcontact.com/au/products/2708863>

Maximum switching voltage	30 V AC (Resistive load)
	42 V AC (peak, resistive load)
Limiting continuous current	0.46 A

Connection data

Supply

Stripping length	7.00 mm
Tightening torque	0.6 Nm ... 0.8 Nm

Interfaces

Bit distortion, input	max. $\pm 35\%$
Bit distortion, output	$< 6.25\%$
Bit delay	1 bit (Direct mode)
Signal	PROFIBUS
Transmission channels	2 (1/1), TD, RD, half duplex

Data: PROFIBUS acc. to IEC 61158, RS-485 2-conductor

Transmission speed	9.6/19.2/45.45/93.75/187.5/500/1500/3000/6000/12000 kbps (can be set manually and automatically)
Connection method	D-SUB-9 female connector
Transmission length	≤ 1200 m (Depends on transmission speed and cable type)
Termination resistor	external
Single conductor/terminal point, rigid	0.2 mm ² ... 2.5 mm ²
Single-wire/terminal point, flexible	0.2 mm ² ... 2.5 mm ²
Max. AWG conductor cross section, flexible	14
Min. AWG conductor cross section, flexible	24
Single-wire/terminal point, rigid AWG max.	14
Single-wire/terminal point, rigid AWG min.	24
Transmission medium	2-wire twisted pair, shielded
File format/coding	UART (11 Bit, NRZ)
Data direction switching	Automatic control, min. station response time 2 bits
Output nominal voltage	5 V DC $\pm 5\%$
Output current	50 mA

Dimensions

Dimensional drawing	
Width	35 mm
Height	99 mm
Depth	105 mm

PSI-REP-PROFIBUS/12MB - Repeater



2708863

<https://www.phoenixcontact.com/au/products/2708863>

Material specifications

Color (Housing)	gray (RAL 7042)
Material (Housing)	PA 6.6-FR

Mechanical tests

Free fall in accordance with IEC 60068-2-32	: 1 m
Vibration resistance in accordance with EN 60068-2-6/IEC 60068-2-6	: 5g, 10...150 Hz, 2.5 h, in XYZ direction
Shock in accordance with EN 60068-2-27/IEC 60068-2-27	: 15g, 11 ms period, half-sine shock pulse

Environmental and real-life conditions

Ambient conditions

Degree of protection	IP20
Ambient temperature (operation)	-20 °C ... 60 °C
Ambient temperature (storage/transport)	-40 °C ... 85 °C
Altitude	≤ 5000 m (For restrictions, see the manufacturer's declaration for altitude operation) ≤ 2000 m (Hazardous locations)
Permissible humidity (operation)	30 % ... 95 % (non-condensing)

Approvals

CE

Certificate	CE-compliant
-------------	--------------

ATEX

Identification	⊕ II 3 G Ex ec IIC T5 Gc
Certificate	UL 21 ATEX 2550X
Note	Please follow the special installation instructions in the documentation!

IECEX

Identification	Ex ec IIC T5 Gc
Certificate	IECEX ULD 21.0013X

UL, USA/Canada

Identification	Class I, Zone 2, AEx ec IIC T5 Gc Ex ec IIC T5 Gc X Class I, Div. 2, Groups A, B, C, D
----------------	--

KC approval for South Korea

Certificate	MSIP-REI-PCK-2708863
-------------	----------------------

Corrosive gas test

Identification	ISA-S71.04-1985 G3 Harsh Group A
----------------	----------------------------------

EMC data

PSI-REP-PROFIBUS/12MB - Repeater



2708863

<https://www.phoenixcontact.com/au/products/2708863>

Electromagnetic compatibility	Conformance with EMC Directive 2014/30/EU
Noise immunity	EN 61000-4-2

Noise emission

Standards/regulations	EN 55011
-----------------------	----------

Electrostatic discharge

Standards/regulations	EN 61000-4-2
-----------------------	--------------

Electrostatic discharge

Contact discharge	± 6 kV
Discharge in air	± 8 kV
Comments	Criterion B

Electromagnetic HF field

Standards/regulations	EN 61000-4-3
-----------------------	--------------

Electromagnetic HF field

Frequency range	80 MHz ... 3 GHz
Field intensity	10 V/m
Comments	Criterion A

Fast transients (burst)

Standards/regulations	EN 61000-4-4
-----------------------	--------------

Fast transients (burst)

Input	± 2 kV
Signal	± 2 kV
Comments	Criterion B

Surge current load (surge)

Standards/regulations	EN 61000-4-5
-----------------------	--------------

Surge current load (surge)

Input	± 0.5 kV
Signal	± 1 kV
Comments	Criterion B

Conducted interference

Standards/regulations	EN 61000-4-6
-----------------------	--------------

Conducted interference

Comments	Criterion A
Voltage	10 V

Emitted interference

Standards/regulations	EN 55011
Comments	Class A, industrial applications

Criteria

PSI-REP-PROFIBUS/12MB - Repeater



2708863

<https://www.phoenixcontact.com/au/products/2708863>

Criterion A	Normal operating behavior within the specified limits.
Criterion B	Temporary impairment to operational behavior that is corrected by the device itself.

Standards and regulations

Free from substances that could impair the application of coating	VDMA 24364:2018-05
Standards/regulations	EN 62368

Mounting

Mounting type	DIN rail mounting
---------------	-------------------

PSI-REP-PROFIBUS/12MB - Repeater



2708863

<https://www.phoenixcontact.com/au/products/2708863>

Drawings

Dimensional drawing

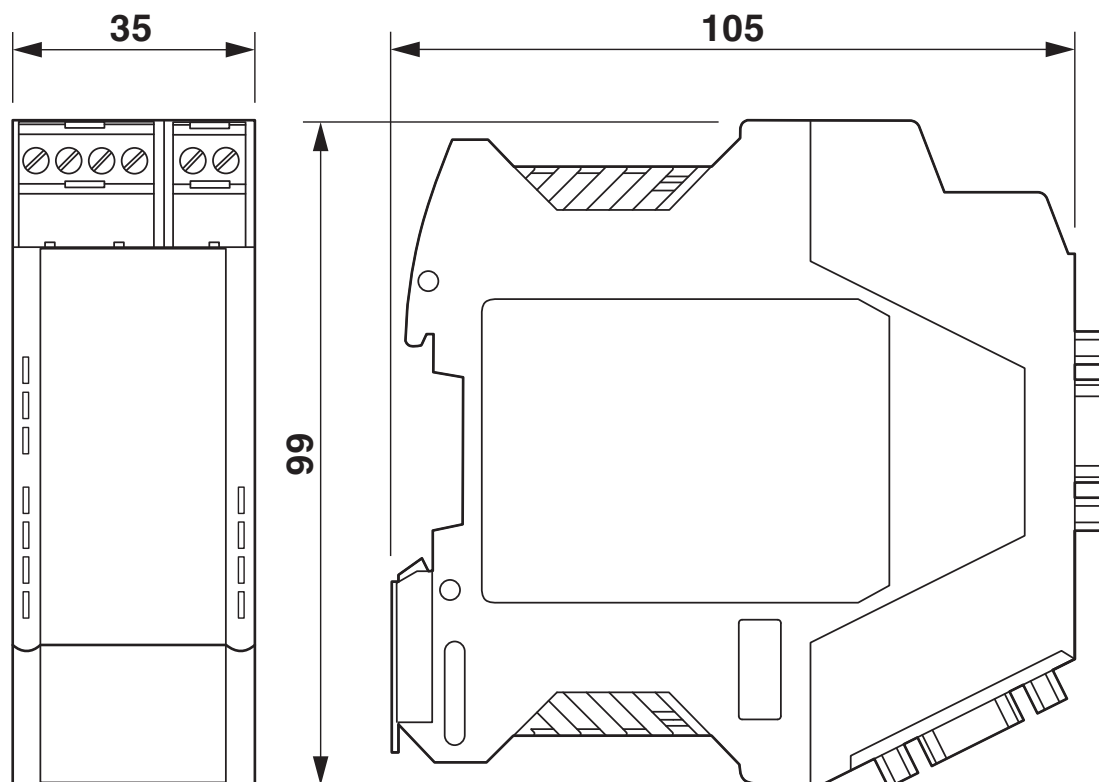

Housing dimensions

Application drawing

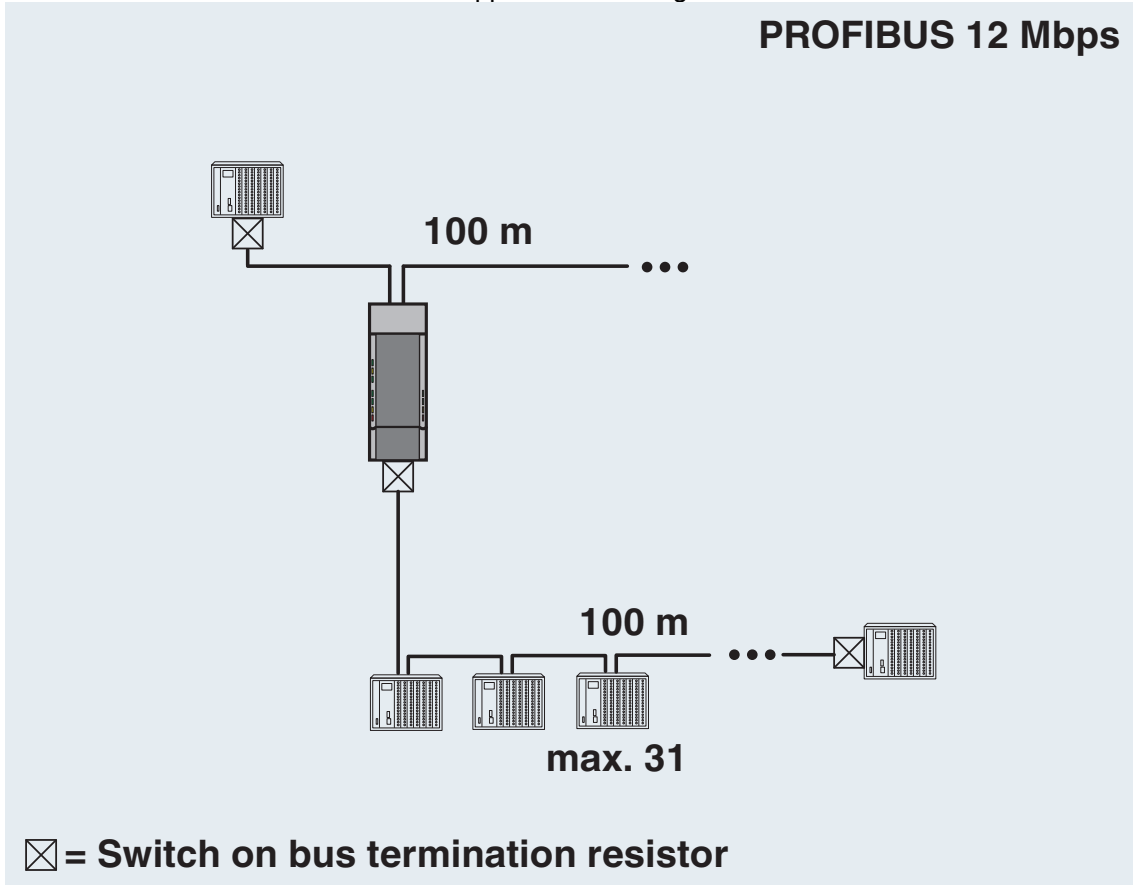

Branch line

PSI-REP-PROFIBUS/12MB - Repeater

2708863

<https://www.phoenixcontact.com/au/products/2708863>

Application drawing

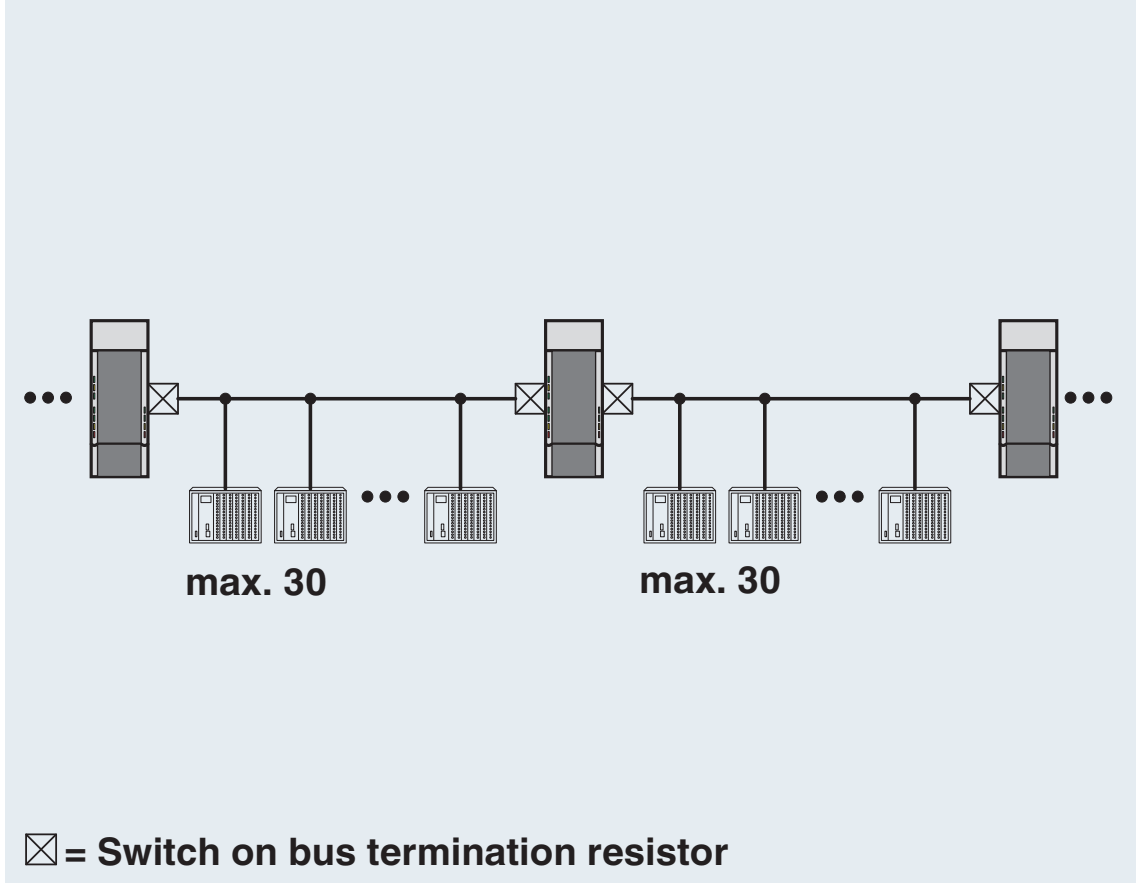

Line structure

PSI-REP-PROFIBUS/12MB - Repeater

2708863

<https://www.phoenixcontact.com/au/products/2708863>

Application drawing

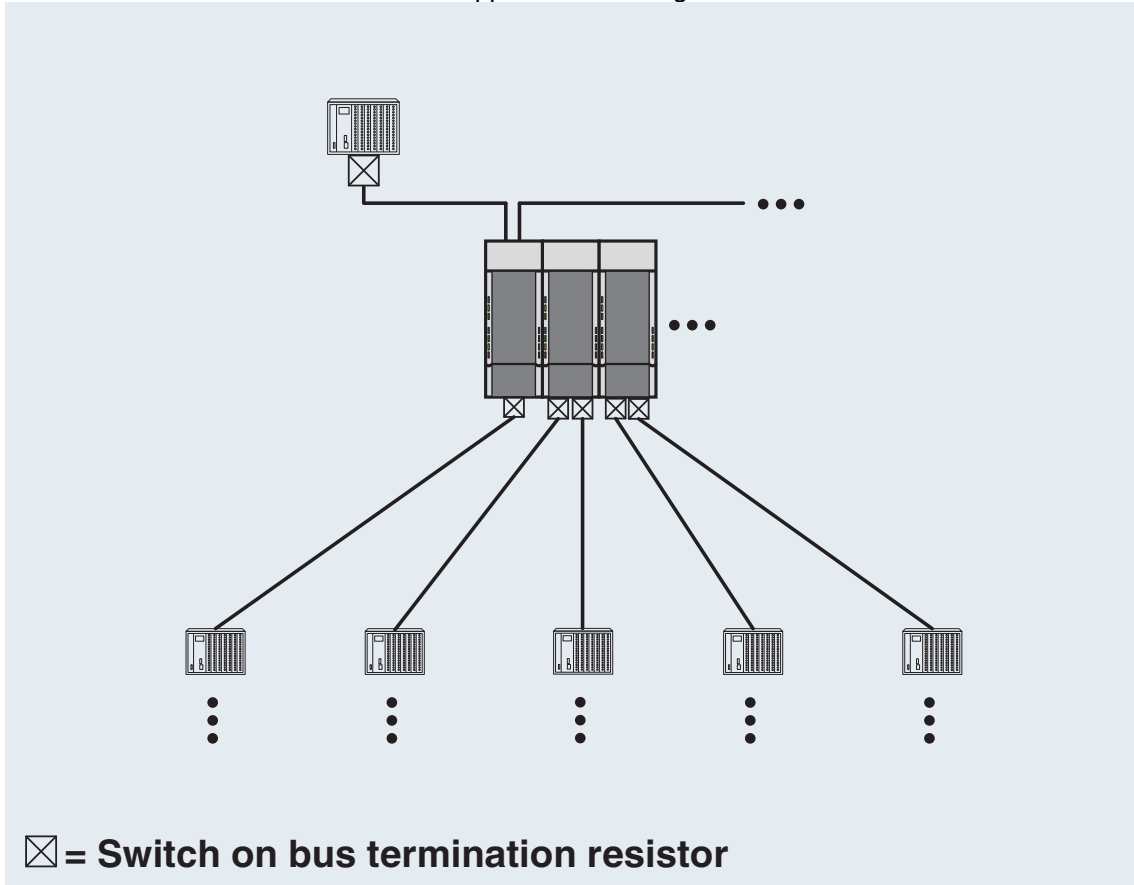

Star structure

PSI-REP-PROFIBUS/12MB - Repeater

2708863

<https://www.phoenixcontact.com/au/products/2708863>

Application drawing

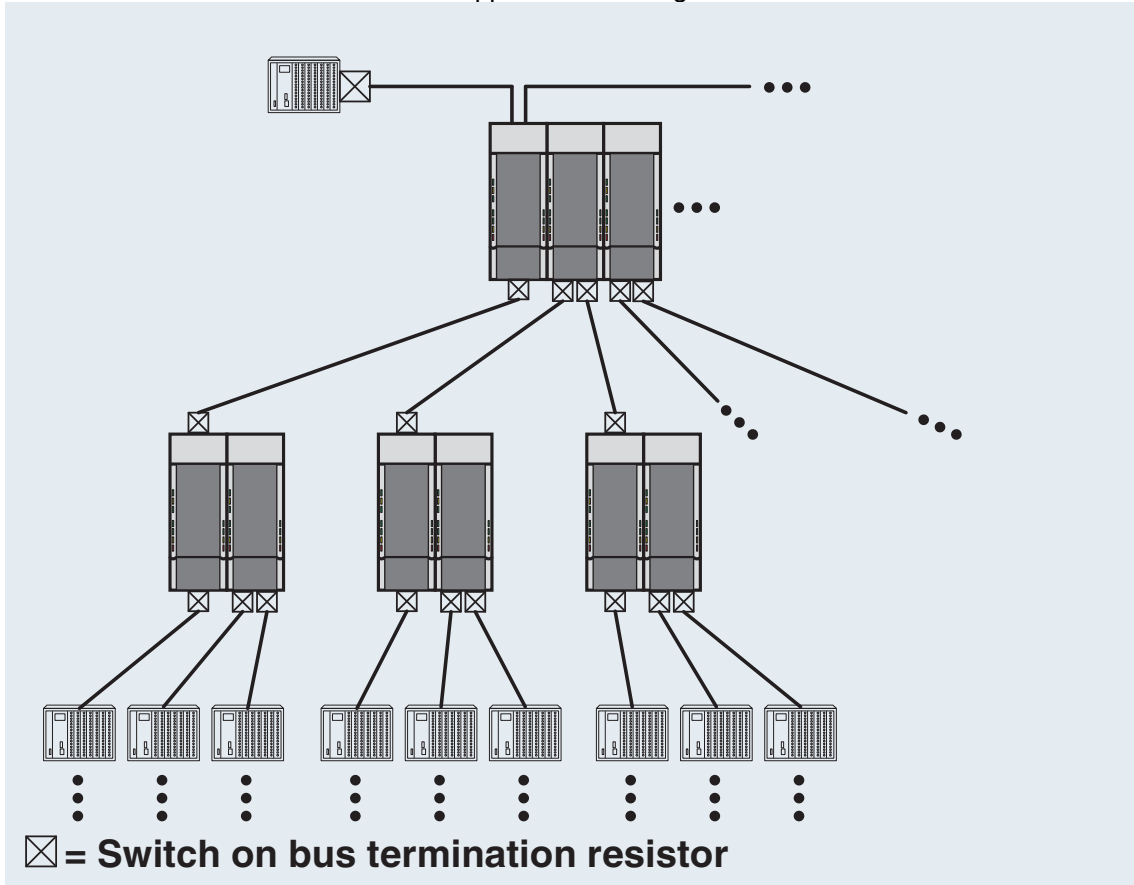

Tree structure

PSI-REP-PROFIBUS/12MB - Repeater



2708863

<https://www.phoenixcontact.com/au/products/2708863>

Schematic diagram

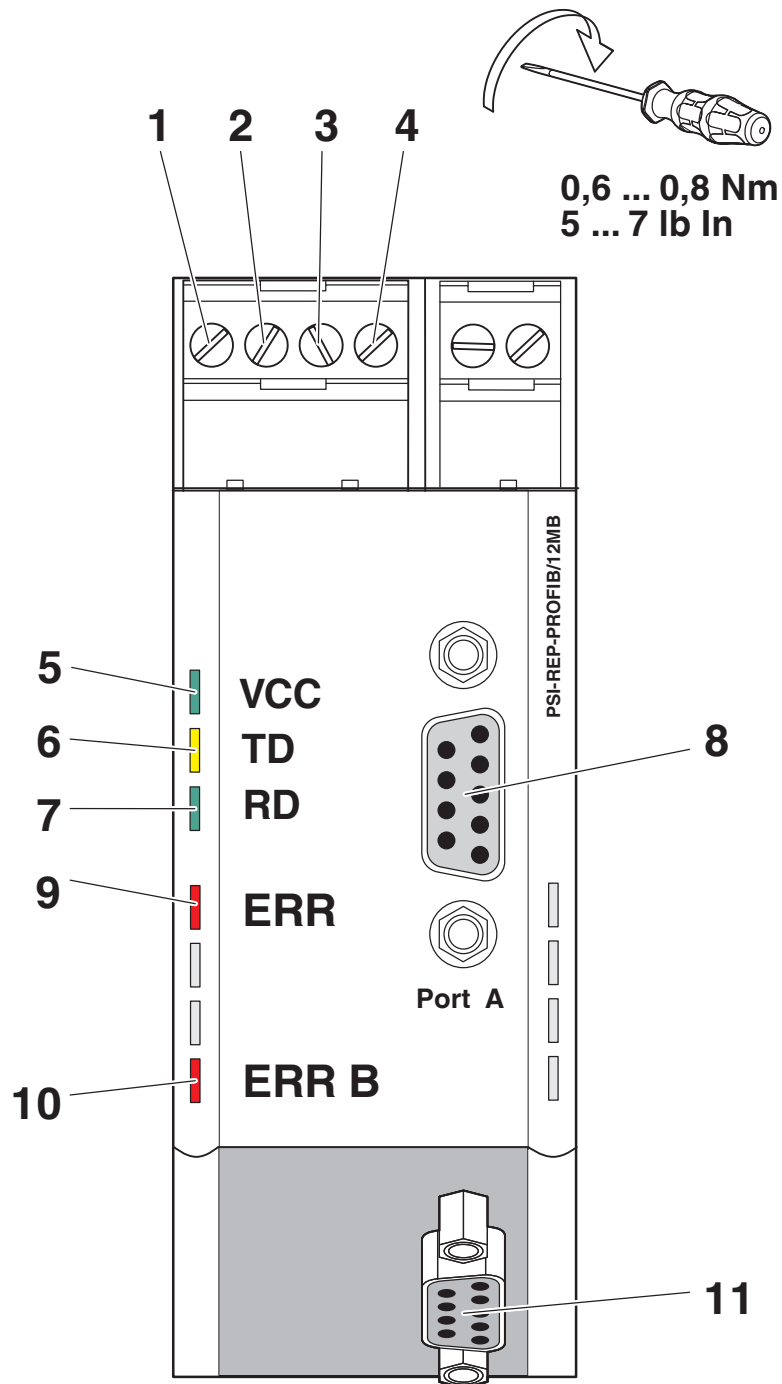

Front view

PSI-REP-PROFIBUS/12MB - Repeater

2708863

<https://www.phoenixcontact.com/au/products/2708863>

Schematic diagram

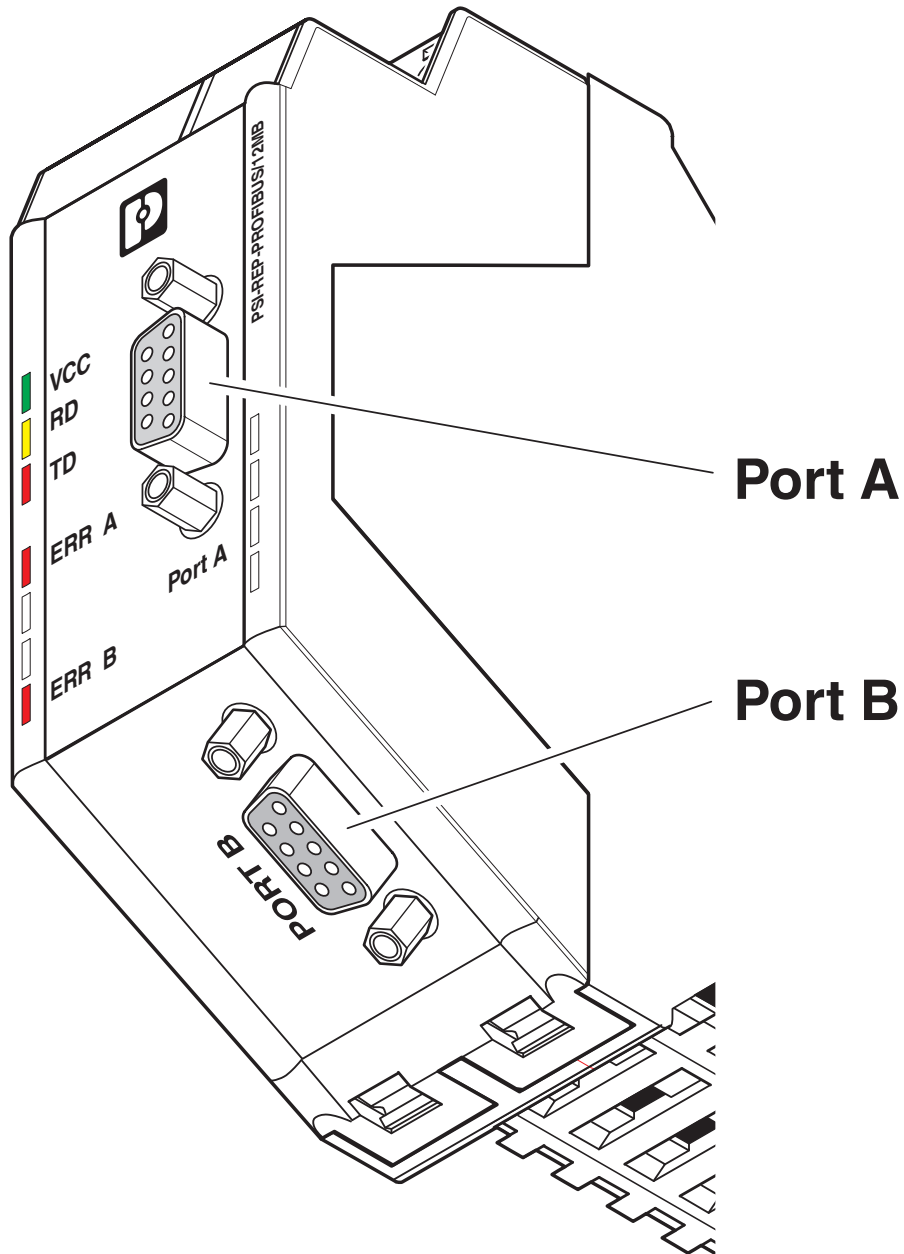

Device connections

PSI-REP-PROFIBUS/12MB - Repeater



2708863

<https://www.phoenixcontact.com/au/products/2708863>

Block diagram

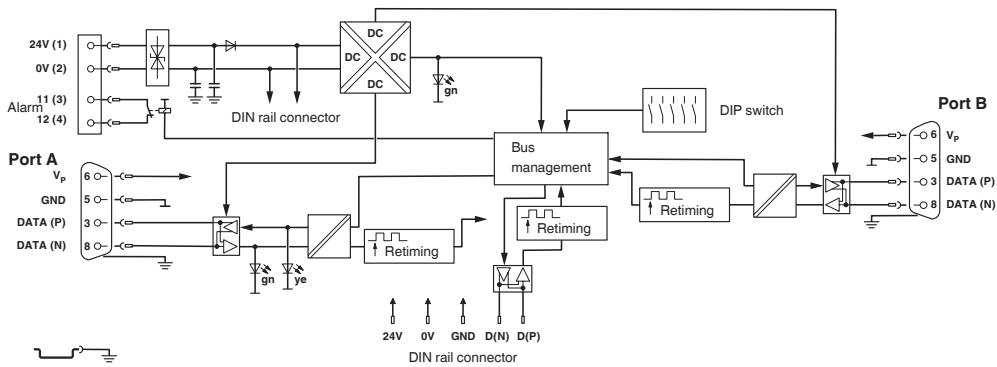

Circuit diagram

PSI-REP-PROFIBUS/12MB - Repeater



2708863

<https://www.phoenixcontact.com/au/products/2708863>

Approvals

To download certificates, visit the product detail page: <https://www.phoenixcontact.com/au/products/2708863>



KC

Approval ID: MSIP-REI-PCK-2708863



cULus Listed

Approval ID: E238705



cULus Recognized

Approval ID: E238705



cUL Listed

Approval ID: E199827



UL Listed

Approval ID: E199827

PSI-REP-PROFIBUS/12MB - Repeater



2708863

<https://www.phoenixcontact.com/au/products/2708863>

Classifications

ECLASS

ECLASS-13.0

27242208

ETIM

ETIM 9.0

EC001423

UNSPSC

UNSPSC 21.0

43222600

PSI-REP-PROFIBUS/12MB - Repeater



2708863

<https://www.phoenixcontact.com/au/products/2708863>

Environmental product compliance

EU RoHS

Fulfills EU RoHS substance requirements	Yes
Exemption	7(a), 7(c)-I

China RoHS

Environment friendly use period (EFUP)	EFUP-50
	An article-related China RoHS declaration table can be found in the download area for the respective article under "Manufacturer declaration". For all articles with EFUP-E, no China RoHS declaration table issued and required.

EU REACH SVHC

REACH candidate substance (CAS No.)	Lead(CAS: 7439-92-1)
SCIP	9db7fad1-e573-4b3c-82c8-9fea0df51fda

Phoenix Contact 2025 © - all rights reserved

<https://www.phoenixcontact.com>

PHOENIX CONTACT PTY Ltd

Unit 7, 2-8 South Street

Rydalmere NSW 2116

1300 786 411

customerservice@phoenixcontact.com.au