

CONTA-CABLE

KDS Cable entries
KES Cable entries
SAB|SSAB|SABK Shielding solutions



Catalogue 08

Contents

Our company	3	KES-E	70
<hr/>		Cable entries	
The advantages online	4	<hr/>	
<hr/>		KES-E-R	74
Globally available for you	5	Round cable entries	
<hr/>		<hr/>	
Catalogues	6	KES-GB-FDA	78
<hr/>		Cable entries for food industry applications	
Product portfolio	8	<hr/>	
<hr/>		KDS BW 1	86
KDSI-SR	10	Actuating tool	
Inverted, modular cable entry system		KDSClick assortment box	
<hr/>		<hr/>	
KDS-SR	18	KDS-EMV-SAB	87
Modular cable entry system		Shield-connection rails	
<hr/>		<hr/>	
KDS-FP	24	KDS-BP	88
Flange plates		Blanking plates	
<hr/>		<hr/>	
KDS-R	32	KDS/KES-VS	89
Round cable entries		Seal plugs for all KDS and KES systems	
<hr/>		<hr/>	
KDS-KV	40	Punching tools	90
Separable cable glands		<hr/>	
<hr/>		Shield-connection clip	94
KDS-FB	46	<hr/>	
Cable entry system for flat cables		Busbar holder	111
<hr/>		<hr/>	
Sealing elements KDS systems	56		
<hr/>			
KDS-DES	58		
Seals			
<hr/>			
KDSClick	60		
Combination options for the modular KDSClick system			
<hr/>			
KES	62		
Cable entries			
<hr/>			



CONTA-CLIP – Thinking ahead with connection technology

CONTA-CLIP was founded in 1978. We operate globally as an owner-operated medium-sized company.

Users of electrical and electronic connection systems trust our reliable products and our many years of industrial and global market expertise.

Our company is now one of the most important manufacturers in the field.

For over 40 years, our components and solutions have been used in process and industrial automation applications, including: railway technology, materials handling, building automation, air conditioning, mechanical and facility engineering, measurement and control technology, control panel construction, shipbuilding, transformer construction and environmental technology.

Over the years, we have evolved into an innovator that sets the tone with new ideas and creative impulses.

Our employees come from a wide variety of industries and are true connectivity specialists. They understand the specific problems, requirements and challenges of our customers. This results in communication among equals.

The profits then flow into the development of new products and into modern, efficient manufacturing processes.

High quality standards throughout all departments are our top priority.

Our top-class products are supported by this interplay between top-class men and machinery. We have also designed our range of services to align with customer needs.

Our products are divided into six categories: CONTA-CONNECT for terminals and accessories, CONTA-CABLE cable management systems, CONTA-ELECTRONICS for electrical and electronic cabinet components, CONTA-LABEL for marking systems, CONTA-BOX for housings, and CONTA-CON for PCB terminals and connectors.

We design customer-specific solutions for electronics, provide completely assembled housings and assemblies as needed, assemble terminal blocks for series production, and quickly handle component labelling tasks.

We greet these challenges with passion and enthusiasm, because we see each customer as our partner.

CONTA-CLIP customer representatives are always ready to offer their support to the customer, because service and helpfulness are rooted deeply in our corporate philosophy.

Advantage online: the CONTA-CLIP Online Catalogue

No matter where you are, as long as you're online you can access our digital catalogue to look at our services and quickly identify suitable solutions for your requirements.

Fast results Use the full-text search, enter an order number or use the convenient "step-by-step" feature search function.

Project planning at a glance: After you've selected the products, all the master data for the materials (sales data, technical data, drawings, connection diagrams, classifications and approvals) are made available as a data sheet or export file.

Detailed inquiries about components can be sent via the shopping cart directly to our headquarters. Upon request, you will receive an e-mailed copy of your inquiry.

Application films: Complex functions be explained easily and clearly with sounds and images.

Printed catalogue: Would you like an offline overview? Please ask for our free printed catalogues.

Industry-specific: You will find the solutions that are relevant for your industry, according to your expertise.

Newsletter: Do you want to stay up to date? Subscribe to our newsletter! Simply register, confirm our authentication e-mail, and you'll be regularly informed about all CONTA-CLIP news.

Discover how the world of CONTA-CLIP and our website can deliver added value for you and your projects!

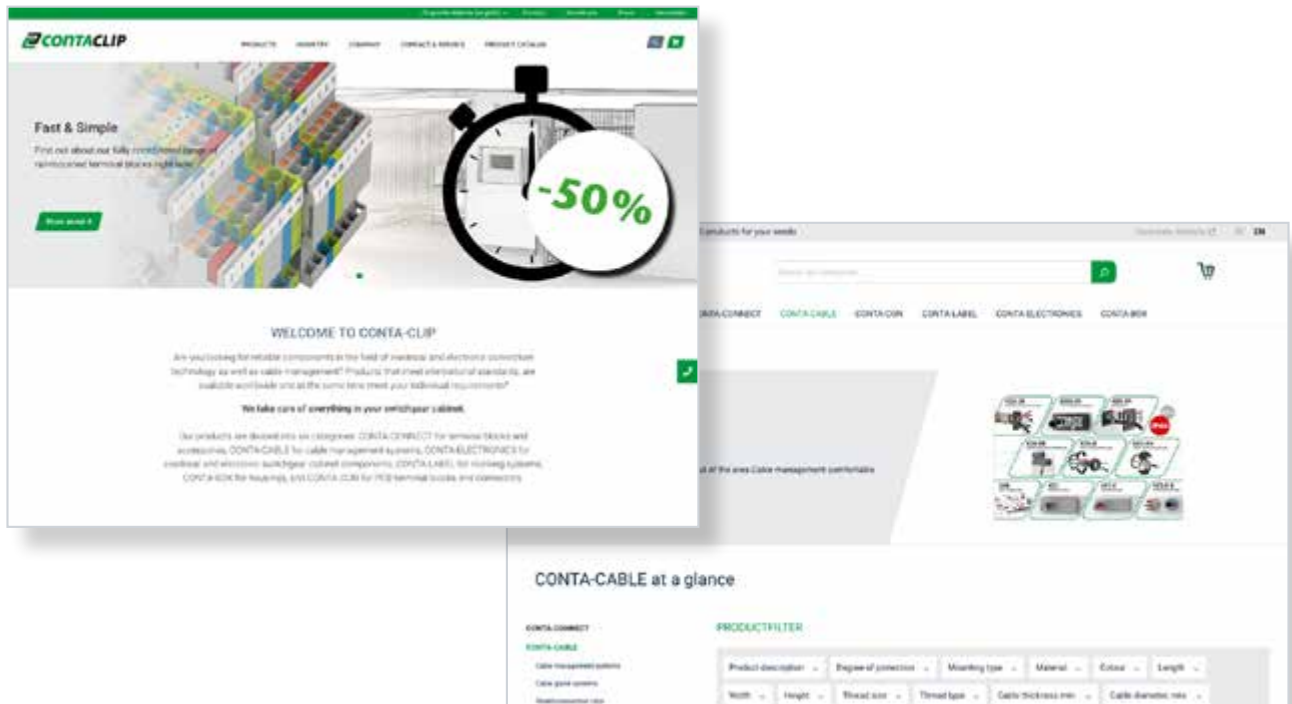

Globally available for you

Are you working abroad? No problem. Our worldwide sales and distribution partners help us to be globally networked and provide on-time reliable deliveries. Simply scan the QR code shown and you'll learn on our website about the sales partner responsible for your country.



Our locations in Africa

Algeria
Morocco
South Africa

Our locations in Asia

Bahrain
China
Hong Kong
India
Israel
Japan
Jordan
Malaysia
Oman
Pakistan
Qatar
Saudi Arabia
Singapore
South Korea
Taiwan
Turkey
United Arab Emirates

Our locations in Oceania

Australia
New Zealand

Our locations in Europe

Austria
Belgium
Bulgaria
Croatia
Czech Republic
Denmark
Finland
France
Germany
Great Britain
Greece
Hungary
Iceland
Ireland
Italy
Latvia
Netherlands

Norway
Poland
Portugal
Romania
Serbia
Slovakia
Slovenia
Spain
Sweden
Switzerland
Ukraine

Our locations in North America

Canada
Mexico
United States

Our locations in South America

Bolivia
Brazil
Chile
Columbia
Ecuador

A complete line of products to meet your demands

The CONTA-CLIP Catalogues



01

CONTA-CONNECT

Terminal blocks with Push-in connection system

Our wide range of innovative PRK and FRK terminal blocks with the Push-in connection system include feed-through terminals, PE terminals, disconnect terminals, fused terminals, multi-level terminals, installation terminals and initiator terminals, for conductor cross-sections from 0.2 mm² to 25 mm².



Cat. no. 98070.2



02

CONTA-CONNECT

Terminal blocks with Screw connection system and special purpose terminals

Everything for classic wiring with screw connection system, also for high currents: SRK feed-through and PE terminals, RK high-temperature variants, TK transformer terminals, HSK high-power stud terminals and the SVB series screw distributor blocks.



Cat. no. 98071.2



03

CONTA-CONNECT

Terminal blocks with Tension-spring connection system

Our versatile line of terminals with tension spring connections for conductor cross-sections from 0.2 mm² to 16 mm² includes: the ZRK/ZSL series of feed-through and PE terminals, the double-level ZRKD/ZSLD, the ZIKD three-level terminal blocks, motor-connection terminals, (blade-) disconnect terminals, fused terminals, direct-mount terminals, and initiator/actuator terminals for transmitting positioning, encoder and alert signals.



Cat. no. 98072.2

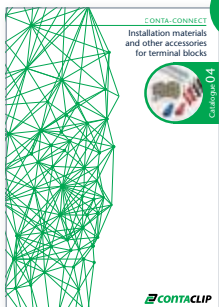

04

CONTA-CONNECT

Installation materials and other accessories for terminal blocks

Our installation products include cabling ducts, assembly tools, cable glands with metric or PG threads, DIN rails, rail cutters and punching tools. The terminal block accessories include different versions of end stops, wire-end ferrules, and connectors.



Cat. no. 98073.2

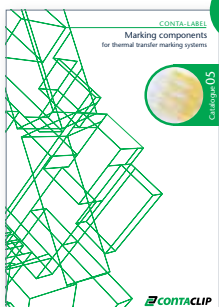

05

CONTA-LABEL

Marking components for thermal-transfer marking systems

CONTA-CLIP provides the TTPCard thermal-transfer printer and a large selection of PC, PVC and PVCF markers or labels in card format: for professional, permanent labelling of terminals, devices, conductors, cables, facilities and electrical cabinets.



Cat. no. 98074.2

Our catalogues are available in many languages!

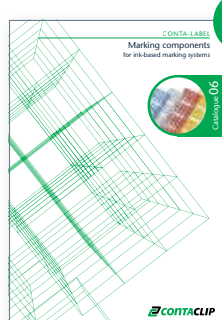

06 CONTA-LABEL

Marking components for ink-based marking systems

The CONTA-LABEL products provide polyamide markers for labelling conductors, cables, devices and facilities with ink print. These markers are available in many shapes and colours: in the classic MC Maxi-Card format for self-printing with the EMS plotter system EMS or other ink-jet systems, or ready-to-use customized printed in the PMC Pocket-Maxi-Card format.

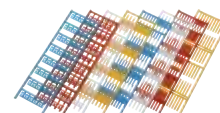

Cat. no. 98075.2

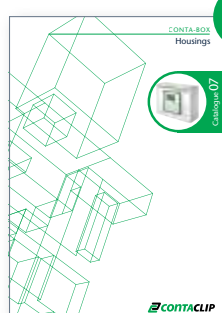

07 CONTA-BOX

Housings

Our wide variety of housings made of polystyrene, polycarbonate, polyester, ABS and aluminium deliver solutions for protecting electronic circuits, integrated devices and terminal blocks. On request, the housings can be custom-processed and assembled with our CONTA-CONNECT, CONTA-ELECTRONICS and CONTA-CON product lines.



Cat. no. 98076.2

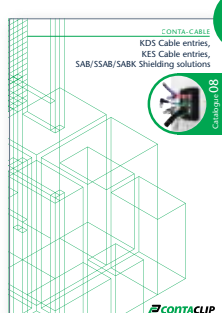

08 CONTA-CABLE

KDS cable entries, KES cable entries, SAB/SSAB/SABK shielding solutions

The KDS and KES cable entries enable a tool-free, IP66-sealed feed-through for un-assembled and assembled cables and hoses. The feed-through openings can be adapted at any time to meet your requirements. The SAB shield-connection clips can be used to provide a reliable shield contact with wire diameters from 3 mm to 35 mm.



Cat. no. 98077.2

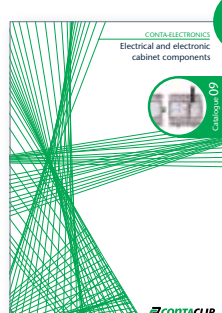

09 CONTA-ELECTRONICS

Electrical and electronic cabinet components

Our CONTA-ELECTRONICS products provide active and passive components for the transfer and conversion of analogue and digital signals at the coupling level. This product line includes power supplies, multi-function timing relays, coupling relays, digital switching modules, interface modules, opto-couplers, signal converters, GSM communication modules and much more.



Cat. no. 98078.2

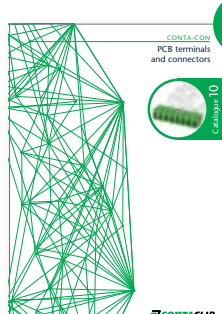

10 CONTA-CON

PCB terminals and connectors

This catalogue presents CONTA-CON's wide range of PCB terminals and plug-in connector systems, as well as the modular feed-through terminal systems of the SDK series. The modular components can be configured for any required number of poles. They are available in the wire connection types: wire protection, eccentric, clamping yoke, and (for demanding operating conditions) with tension-spring or Push-in wire terminations.

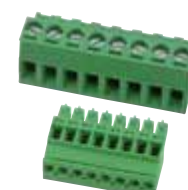

Cat. no. 98079.2

Cable management systems

KDS cable entries

The **KDS** cable entry system has a modular design consisting of frames, frame inlays and seals. This enables quick and easy dimensioning of feed-through openings for pre-assembled cables – without the use of tools. The system reliably ensures an IP66 seal. Since the diameter, shape (round or with corners) and number of frame openings can be adapted at any time without any costly dismantling of the frame, electrical cabinets or machine housings can be uniformly prepared for different purposes using KDS. This results in significantly less costs and warehousing overhead. Our wide range of **KDS** seals currently includes more than 140 variants and is constantly being expanded.

KES cable entries

The **KES** cable entries enable unassembled cables or pneumatic hoses to be quickly inserted into electrical cabinets or housings without using tools. The **KES** entry plates feature a dimensionally stable, elastomer-encapsulated polyamide frame. In order to insert the required number of cables, the surface membrane is first pierced with a screwdriver. Then, the unassembled cables are easily pushed through. Tapered inlet grommets on the back of the plate provide IP66 sealing and reliable strain relief. With up to 32 cables per plate, the **KES** achieves a significantly higher packaging density than conventional entry systems.

The **KES-E** cable entry system enables you to insert many cables (without plugs) with diameters ranging from 1.0 mm to 16.1 mm into a very confined space. No tools are needed to insert the cable entry into the opening provided. For inserting the cables, the appropriate membrane is pierced and the cables are simply installed through it. The material TPE guarantees that IP54 protection is maintained.



Get started
now with
CONTA-CLIP!

SAB|SSAB|SABK shielding solutions

The **SAB** shield-connection clips provides an easy tool-free contact for the cable shield. It is a modular system for mounting on DIN rails, busbars or direct mounting. The system includes shield-connection brackets for cable diameters from 1.5 mm to 65 mm, clamp mounting feet for all attachment types, busbar holders and shield-connection clips with screw or spring contacts. The stripped cable is easily pushed into the **SABK** shield-connection clips. The spring force in the clip then ensures that the shield has a consistently good contact. The large-area shield contact ensures low-impedance discharge resistances, even at high frequencies. The **SAB/SSAB** shield-connection clips cover a clamping range for cable diameters from 3 mm to 35 mm. Busbar supports and end stops for mounting to the bars also supplement this product line.



KDSI-SR Inverted, modular cable entry system

The inverted **KDSI-SR** screw frames enable a complete assembly from the outside. They extend the range of our proven KDS cable entry systems.

Page 10



KDS-SR Modular cable entry system

The **KDS-SR** screw frames are available in 4 different sizes. The inlays make a wide variety of combinations possible.

Page 18



KDS-FP Flange plates

The **KDS-FP** flange plates are available in 2 different sizes. The inlays make a wide variety of combinations possible.

Page 24

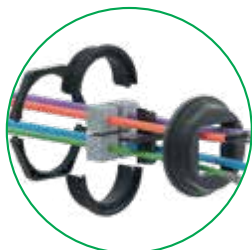

KDS-R Round cable entries

Thanks to three different thread and locking adapters and two external frame sizes, the metric break-through sizes M20 to M32 and M40 to M63 can be equipped modularly with the round **KSR-R** cable entries. Assembly is carried out from the outside inwards.

Page 32



KDS-KV Separable cable glands

The **KDS-KV** separable cable glands are designed for metric cut-outs of 20 to 63 mm diameter.

Page 40



KDS-FB Cable entry system for flat cables

The **KDS-FB** cable entry system for flat cables provides you with outstanding versatility and saves you time while managing cables, especially for industrial trucks, crane systems and elevator applications.

Page 46

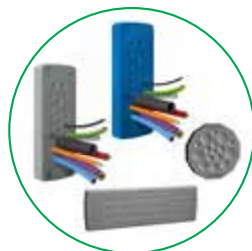

KES Cable entries

The **KES**, **KES-R**, **KES-GB**, **KES-E** and **KES-E-R** cable entry systems are suitable when feeding in unassembled cables or pneumatic and hydraulic hoses. The **KES-GB-FDA**, which are made of FDA-compliant TPE, are available for use in food industry applications.

Page 62

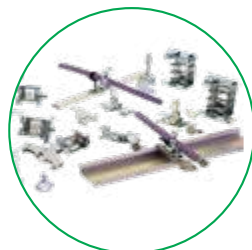

SAB Shielding solutions

Our shield-connection clip products provide a modular system for direct installations, busbar mounting or DIN-rail mounting.

Page 94

KDSI-SR

Inverted, modular cable entry system

The inverted **KDSI-SR** screw frames enable a complete assembly from the outside. They extend the range of our proven **KDS** cable entry systems. The design and the simple, established assembly principle remain practically unchanged. The changes to the inverted versions are the new mirrored geometry of the frame's opening tapers and an additional two-part protective hood, which ensures the tight fit of the sealing elements towards the outside.

The safe IP66 seal and the reliable static strain relief in accordance with DIN EN 62444 is further ensured by the integrated frame gaskets and the conical shape of the sealing elements, which are pressed into the frame openings from the outside.

As with all **KDS** cable entry systems, the modular click-and-plug principle of the **KDSI-SR** means that individual cable entry openings and seals can be reconfigured at any time as required without any extra installation work.

IP66



Your advantages

- Complete assembly from outside inwards
- Guarantee retained for assembled cables
- Retrofitting and servicing can be done quickly and easily
- High-density assemblies
- Protection: IP66

The basic components of the modular system

Frames. Inlays. Seals. Protective hood. The modular design – with four basic components – provides more versatility, variability and variety.

1. Frame

Made from a single mould, the one-piece frame is quick and easy to assemble. It is made of sturdy, glass-fibre reinforced plastic. The integrated TPE gasket guarantees an optimal seal with IP66 protection, even on painted or rough surfaces. The frames also fit the standard cut-outs for 10-, 16- and 24-pole connectors.



2 Inlays

The click-in inlays enable needs-based dimensioning of the frame opening, corresponding to the seal being used. An audible "click" confirms a correct installation. So you can variably configure cable entries to match various requirements (for cables, lines, tubing, pneumatic and hydraulic lines).



3. Seals

The conical shape of the sealing elements allows them to be easily pressed in. This also reliably seals the gaps and provides static strain relief in accordance with DIN EN 62444. The seals are installed by pressing them from the outside inwards into the openings of the previously installed inlays.

Their wave-cut profile makes them easy to install and ensures a perfect fit around the cables. There are currently over 140 different seals that can be used for sealing cables of various diameters and sizes.



4. Protective hood

The two-part protective hood has TPE gaskets at three different levels; this ensures that an IP66 seal is achieved.

The two-part protective hood also guarantees the tight fit of the pressed-in sealing elements to the outside and covers the screws of the one-part frame.



Your advantages: More versatility and safety

The sealing elements can be released by pressing from the inside to the outside. Changes, retrofits, servicing or the readjustment of the cable lengths can be made at any time without dismantling the frame.

KDSI-SR

Inverted, modular cable entry system

An overview of your advantages

Attaching the frame

The one-piece frame can be easily and quickly attached to the wall.



Fast assembly from outside inwards for easier, friendlier servicing

The frame does not need to be disassembled if your requirements change or if you're carrying out service work.



Protective hood

The two-part protective hood has TPE gaskets at three levels and guarantees IP66 protection. A tight fit for the sealing elements, pressed in from the outside, is also guaranteed.



No loss of guarantee: assembled cables

No need to disassemble and reconnect connectors, so manufacturer's warranty is not voided.



Optional external locking mechanism

The optional external locking mechanism **KDSI-AVR** secures the sealing elements so that they cannot be pressed out without tools.



Versatile, high-density assemblies are possible

1-way, 2-way, 3-way and 4-way seals and dummy plugs provide you with excellent versatility for cable management.

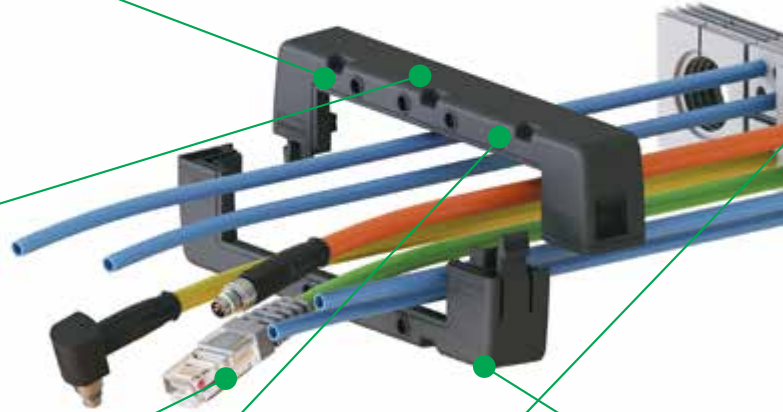
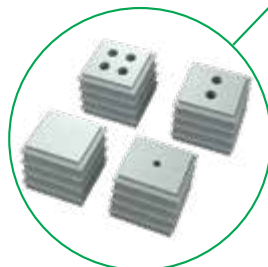

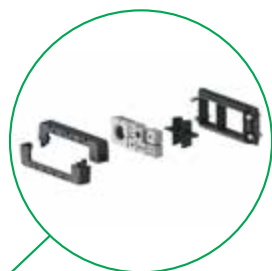
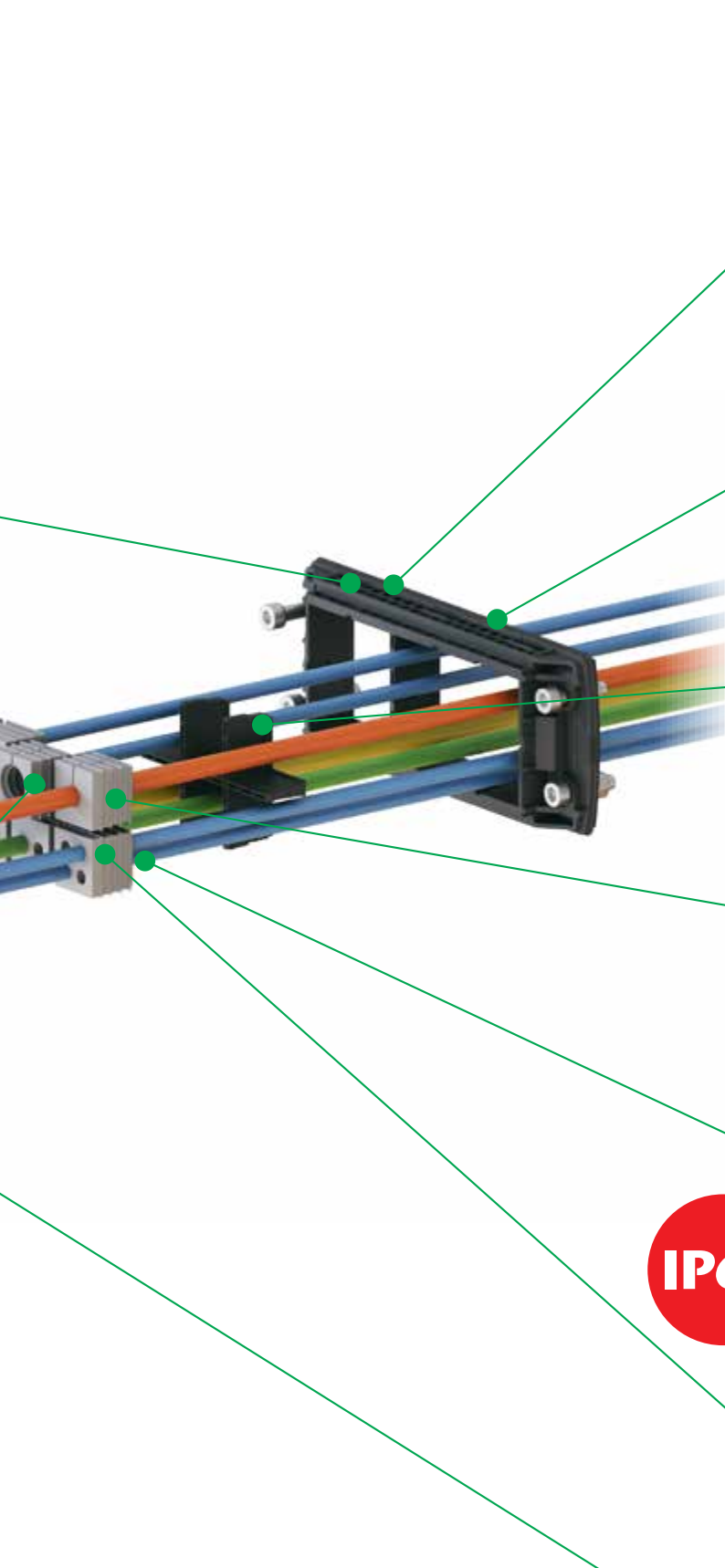

Outstanding versatility with optimized warehousing
 The frames, inlays, seals and protective hoods can be combined in many ways – ensuring you many versatile configuration options.

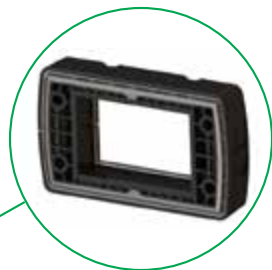

Captive gasket
 The integrated frame gasket eliminates the risk of incorrect assembly (forgotten gasket) and speeds up the assembly process.



Safe and quick installation with feedback
 An audible "click" confirms that the inlay has been properly installed in the frame.



Integrated strain relief
 The absolute tight fit of the sealing elements also ensures a static strain relief mechanism for the cables according to DIN EN 62444.



IP66

Outstanding IP66 seal
 Conic-tapered seals feature inner and outer sealing gills.



Smart separation of the seals
 The wave-cut profile makes them easy to install and ensures a perfect fit around the cables.

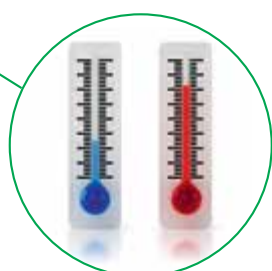

Can be used from -40 °C to +120 °C
 Materials contain no halogen or silicone, suitable for many different applications.

	UL TYPE Rating 12	UL TYPE* Rating 4x	
IP66	RoHS compliant	Made in Germany	

* 4x is for indoor use only

KDSI-SR

Inverted, modular cable entry system

Frames and inlays	KDSI-SR 1-4	KDSI-SR 6/10	KDSI-SR 8/16	KDSI-SR 10/24
				
Diagram	Page 16	Page 16	Page 16	Page 16
Type	KDSI-SR 1-4 BK	KDSI-SR 6/10 BK	KDSI-SR 8/16 BK	KDSI-SR 10/24 BK
Cat. no.	28880.4	28881.4	28882.4	28883.4
Qty.	1	1	1	1
Description	Screw frame with two-part protective hood	Screw frame with two-part protective hood	Screw frame with two-part protective hood	Screw frame with divided protective hood
Type / Set	KDSI-Set 1-4 BK	KDSI-Set 6/10 BK	KDSI-Set 8/16 BK	KDSI-Set 10/24 BK
Cat. no.	28890.4	28891.4	28892.4	28893.4
Qty.	1	1	1	1
Description	1 x KDSI-SR 1-4 BK, 1 x KDS-Inlay 4 BK	1 x KDSI-SR 6/10 BK, 1 x KDS-Inlay 2 BK, 1 x KDS-Inlay 6 BK	1 x KDSI-SR 8/16 BK, 1 x KDS-Inlay 1 BK, 2 x KDS-Inlay 4 BK	1 x KDSI-SR 10/24 BK, 1 x KDS-Inlay 2 BK, 1 x KDS-Inlay 4 BK, 1 x KDS-Inlay 6 BK
Set consists of:				
Accessories				
Inlay	KDS-Inlay 1 BK	KDS-Inlay 1 BK	KDS-Inlay 1 BK	KDS-Inlay 1 BK
Cat. no.	28516.4	28516.4	28516.4	28516.4
Qty.	5	5	5	5
Description	For separating vertically	For separating vertically	For separating vertically	For separating vertically
Inlay	KDS-Inlay 2 BK	KDS-Inlay 2 BK	KDS-Inlay 2 BK	KDS-Inlay 2 BK
Cat. no.	28517.4	28517.4	28517.4	28517.4
Qty.	5	5	5	5
Description	T-shape	T-shape	T-shape	T-shape
Inlay	KDS-Inlay 4 BK	KDS-Inlay 4 BK	KDS-Inlay 4 BK	KDS-Inlay 4 BK
Cat. no.	28518.4	28518.4	28518.4	28518.4
Qty.	5	5	5	5
Description	for 4-way splits	for 4-way splits	for 4-way splits	for 4-way splits
Inlay		KDS-Inlay 6 BK	KDS-Inlay 6 BK	KDS-Inlay 6 BK
Cat. no.		28519.4	28519.4	28519.4
Qty.		5	5	5
Description		for 6-way splits	for 6-way splits	for 6-way splits
Replacement protective hood (two-part)	KDSI-AD 1-4 BK	KDSI-AD 6/10 BK	KDSI-AD 8/16 BK	KDSI-AD 10/24 BK
Cat. no.	28885.4	28886.4	28887.4	28888.4
Qty.	1	1	1	1
Description	Spare cover	Spare cover	Spare cover	Spare cover
Outer locking mechanism (optional)	KDSI-AVR BK	KDSI-AVR BK	KDSI-AVR BK	KDSI-AVR BK
Cat. no.	28894.4	28894.4	28894.4	28894.4
Qty.	20	20	20	20
Sheet-metal hole punch	BL KDS-SR 1-4	BL KDS-SR 6/10	BL KDS-SR 8/16	BL KDS-SR 10/24
Cat. no.	28674.0	28675.0	28676.0	28677.0
Qty.	1	1	1	1
Description	For sheet steel up to 2 mm; also for marking drilling hole points	For sheet steel up to 2 mm; also for marking drilling hole points	For sheet steel up to 2 mm; also for marking drilling hole points	For sheet steel up to 2 mm; also for marking drilling hole points
Actuating tool	KDS BW 1	KDS BW 1	KDS BW 1	KDS BW 1
Cat. no.	28622.0	28622.0	28622.0	28622.0
Qty.	1	1	1	1
Seals				
Grey	Small and large	Small and large	Small and large	Small and large
Cat. no.	Page 56	Page 56	Page 56	Page 56
Seals				
Black	Small and large	Small and large	Small and large	Small and large
Cat. no.	Page 57	Page 57	Page 57	Page 57



Features

- Material: polyamide PA 6.6, glass-fibre reinforced | TPE
- Colour: black
- Flammability: UL 94 V-0
- Temperature range: -40 °C to +120 °C
- Halogen-free, silicone-free
- Protection: IP66



UL TYPE
Rating
12

UL TYPE*
Rating
4x

IP66

RoHS
compliant

**Made in
Germany**



* 4x is for indoor use only

KDSI-SR Combination examples

KDSI-SR 1-4



KDSI-SR 6/10



KDSI-SR 8/16



KDSI-SR 10/24



KDSI-SR

Dimensional diagrams and mounting cut-outs

KDSI-SR 1-4

Dimensional diagram

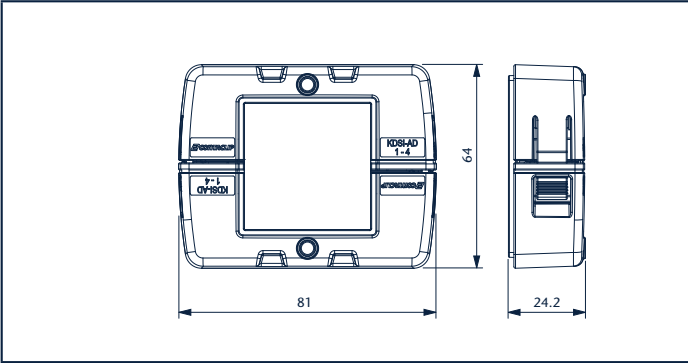

Mounting cut-out

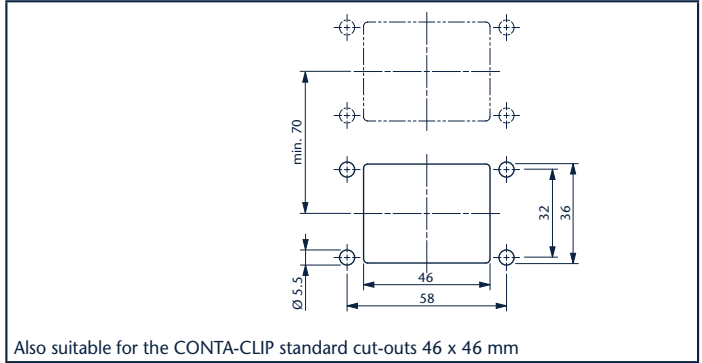

Also suitable for the CONTA-CLIP standard cut-outs 46 x 46 mm

Torque for the frame's mounting screw: 3 Nm

Screw for usage: ISO 4762 / DIN 912

KDSI-SR 6/10

Dimensional diagram

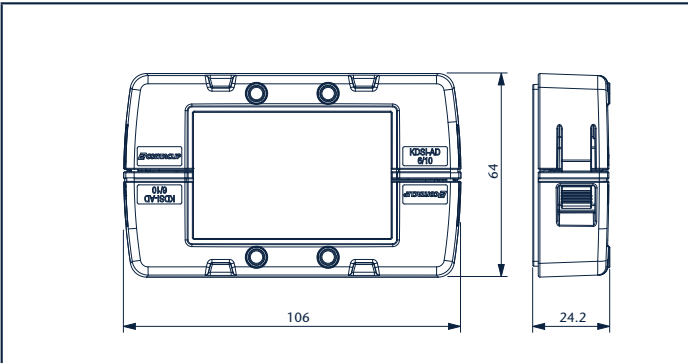

Mounting cut-out

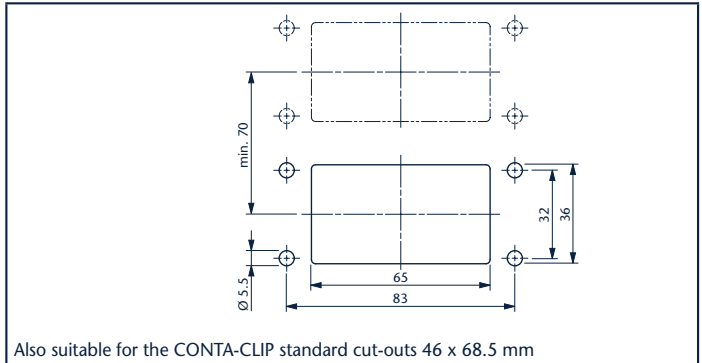

Also suitable for the CONTA-CLIP standard cut-outs 46 x 68.5 mm

Torque for the frame's mounting screw: 3 Nm

Screw for usage: ISO 4762 / DIN 912

KDSI-SR 8/16

Dimensional diagram

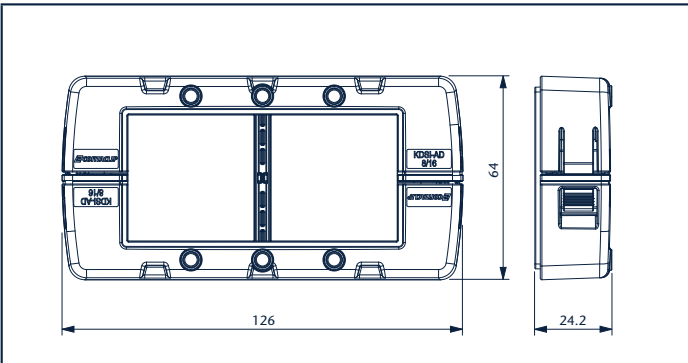

Mounting cut-out

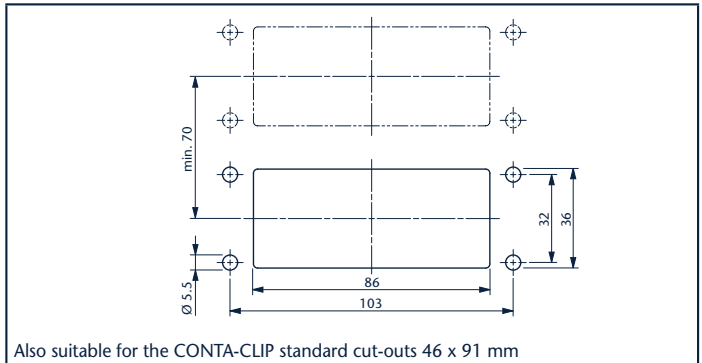

Also suitable for the CONTA-CLIP standard cut-outs 46 x 91 mm

Torque for the frame's mounting screw: 3 Nm

Screw for usage: ISO 4762 / DIN 912

KDSI-SR 10/24

Dimensional diagram

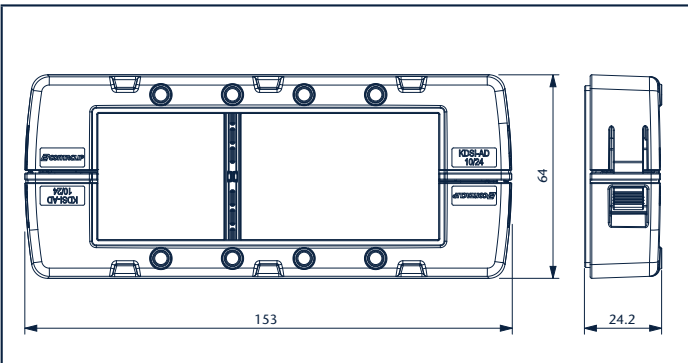

Mounting cut-out

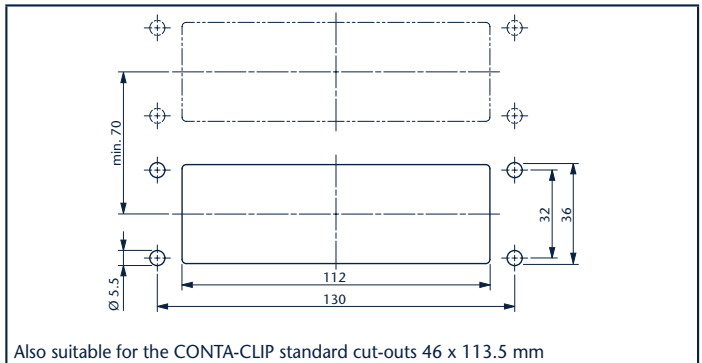

Also suitable for the CONTA-CLIP standard cut-outs 46 x 113.5 mm

Torque for the frame's mounting screw: 3 Nm

Screw for usage: ISO 4762 / DIN 912

Notes

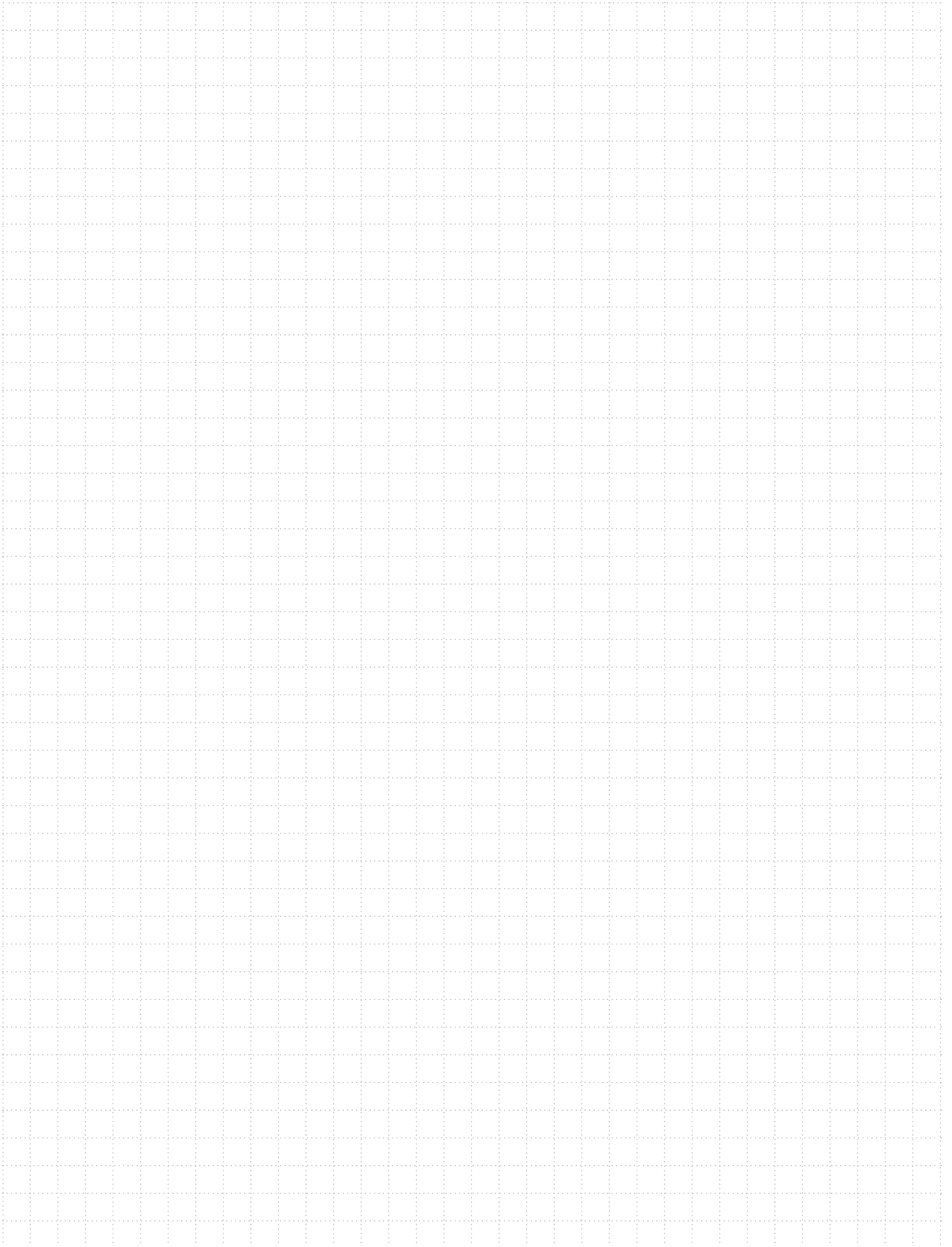

KDS-SR Modular cable entry system

A revolutionary cable entry systems:

Fast. Safe. Turning cables inside out!

The **KDS-SR** cable entry system is a cable management solution for electrical cabinets, housings and machines that features secure seals and strain relief for pre-assembled and non-assembled cables – with or without connectors. This saves you time and provides you with maximum versatility.

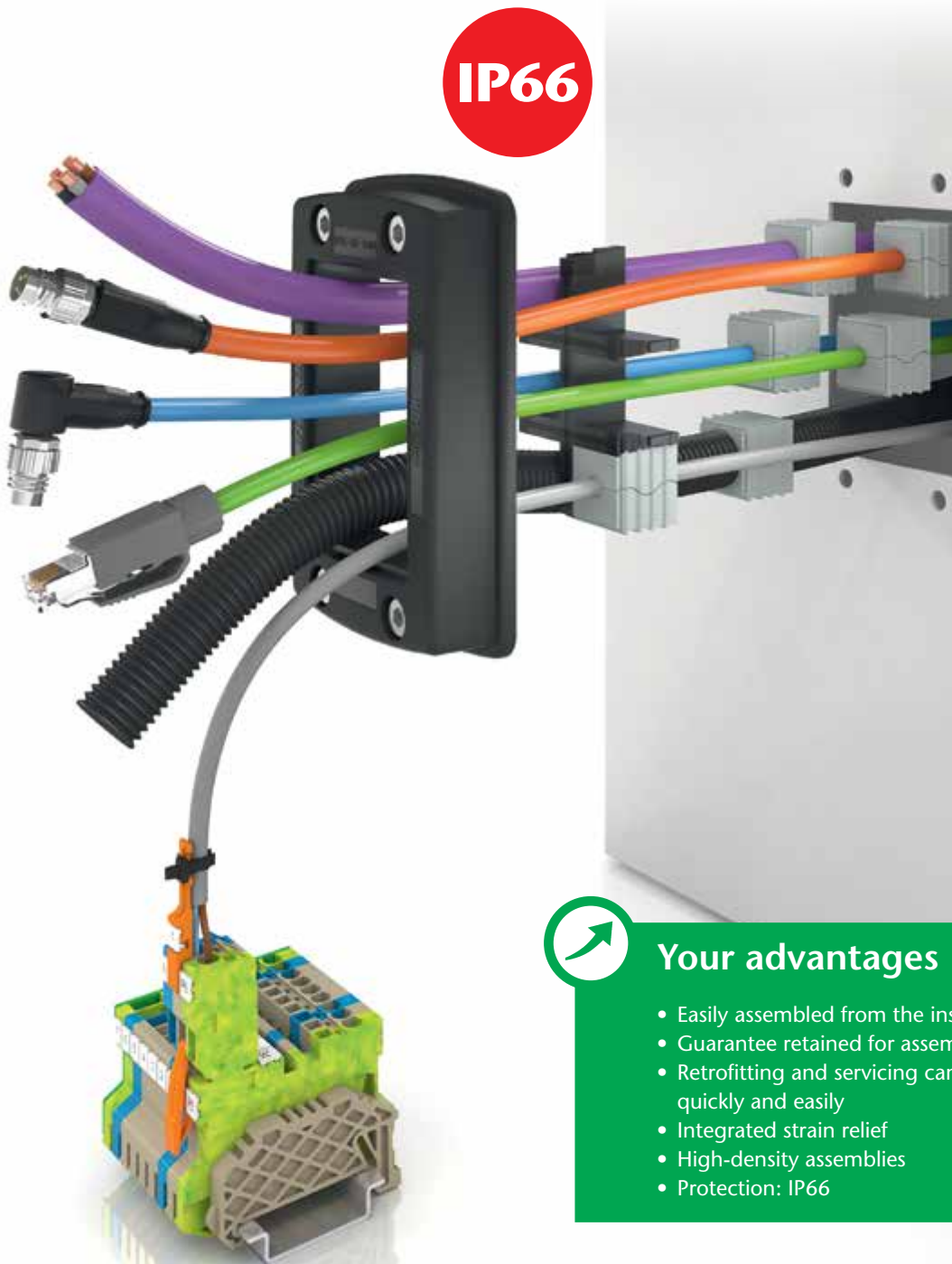

Your advantages

- Easily assembled from the inside
- Guarantee retained for assembled cables
- Retrofitting and servicing can be done quickly and easily
- Integrated strain relief
- High-density assemblies
- Protection: IP66

The basic components of the modular system

Frames. Inlays. Seals. The modular design – 3 basic components – provides more versatility, variability and variety.

1. Frame

Made from a single mould, the one-piece frame is quick and easy to assemble. It is made of sturdy, glass-fibre reinforced plastic. The foamed gasket guarantees an optimal seal with IP66 protection, even on painted or rough surfaces.



2 Inlays

The click-in inlays enable needs-based dimensioning of the frame opening, corresponding to the seal being used. An audible "click" confirms a correct installation. So you can variably configure cable entries to match various requirements (for cables, lines, tubing, pneumatic and hydraulic lines).



3. Seals

The conical shape of the sealing elements allows them to be easily pressed in. This also reliably seals the gaps and provides static strain relief in accordance with DIN EN 62444. The seals are installed by pressing them from the inside outwards into the openings of the previously installed inlays. Their wave-cut profile makes them easy to install and ensures a perfect fit around the cables. There are currently over 140 different seals that can be used for sealing cables of various diameters and sizes.



Your advantages: More versatility and safety

The seals can be removed by pressing from the outside inwards. Changes, retrofits, servicing or the readjustment of the cable lengths can be made at any time without dismantling the frame. Unwanted manipulations from the outside can be prevented by using an optional inner locking frame.

KDS-SR Modular cable entry system

Supported by:



on the basis of a decision
by the German Bundestag

An overview of your advantages

Attaching the frame

The one-piece frame can be easily and quickly attached to the wall.



Quick inside-outwards assembly for easier servicing work

The frame does not need to be disassembled if your requirements change or if you're carrying out service work.



Captive gasket

The foamed-in frame gasket eliminates the risk of incorrect assembly (forgotten gasket) and speeds up the assembly process.

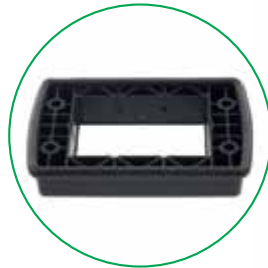

Smart separation of the seals

The wave-cut profile makes them easy to install and ensures a perfect fit around the cables.



No loss of guarantee: assembled cables

No need to disassemble and reconnect connectors, so manufacturer's warranty is not voided.

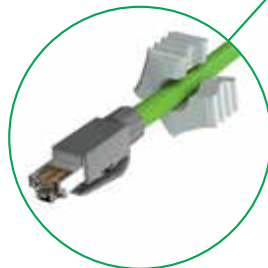

Versatile, high-density assemblies are possible

1-way, 2-way, 3-way and 4-way seals and dummy plugs provide you with excellent versatility for cable management.

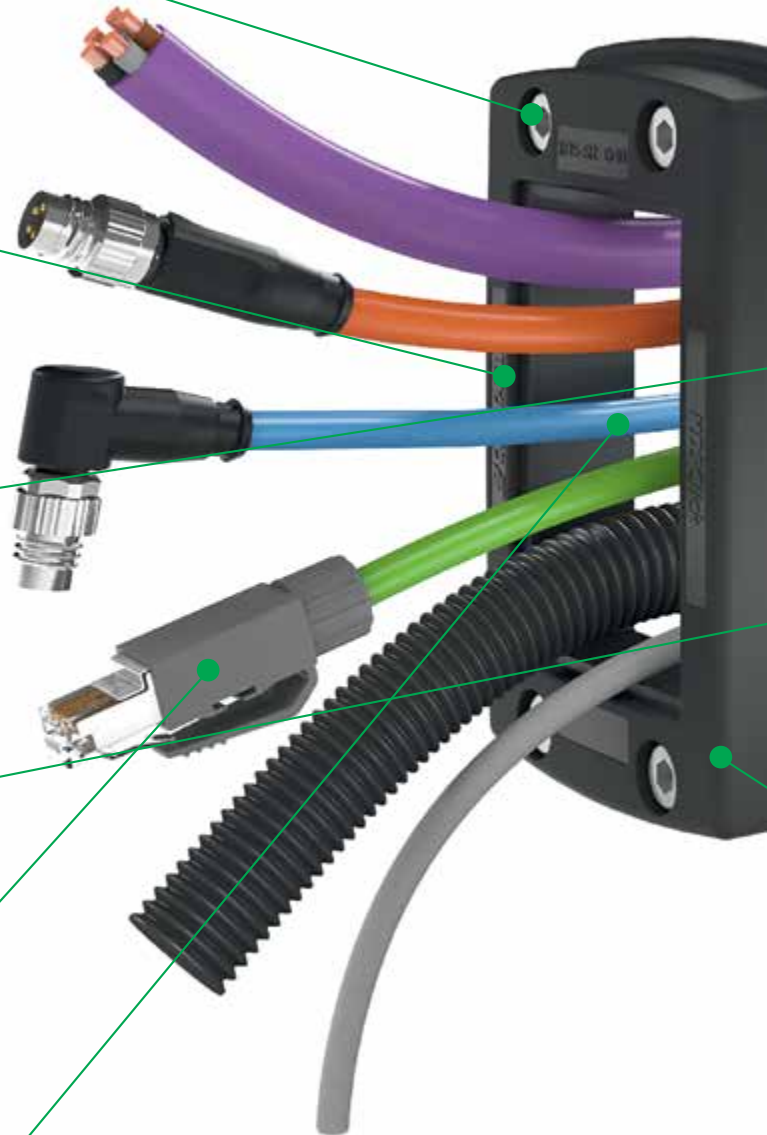

KDS CLICK

by CONTA-CLIP

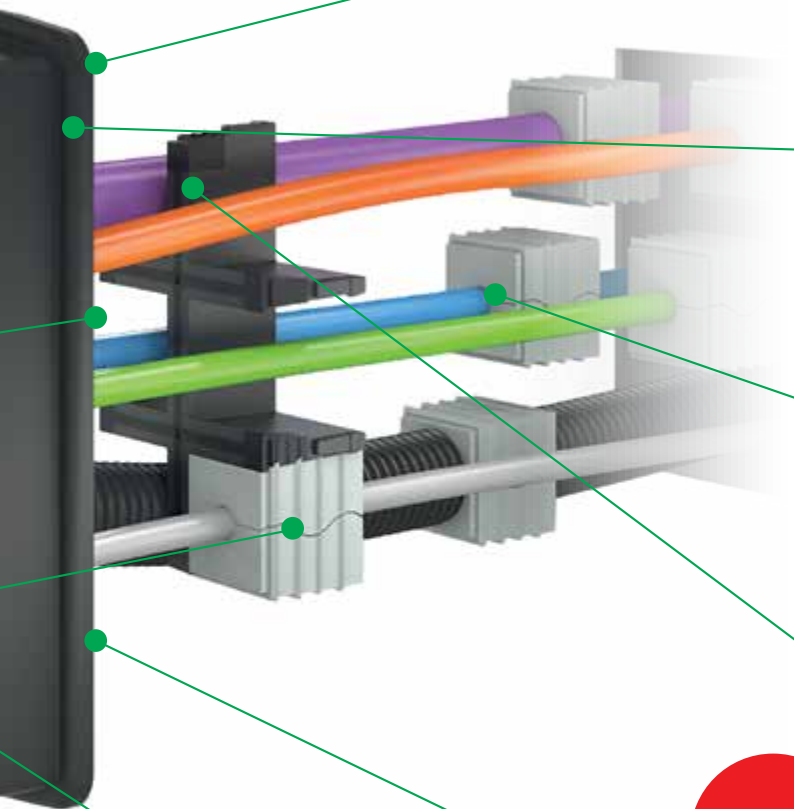

Outstanding versatility with optimized warehousing

The frames, inlays and seals can be combined in many ways – ensuring you many versatile configuration options.



Safe and quick installation with feedback

An audible "click" confirms that the inlay has been properly installed in the frame.



Integrated strain relief

The absolute tight fit of the sealing elements also ensures a static strain relief mechanism for the cables according to DIN EN 62444.

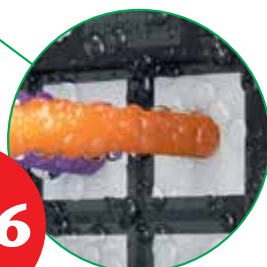

Outstanding IP66 seal

Multi-resistant, tapered seals feature inner and outer sealing gills.

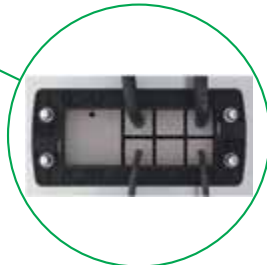

Inner locking frame

The optional locking frame ensures that the seals cannot be pushed out without using tools.

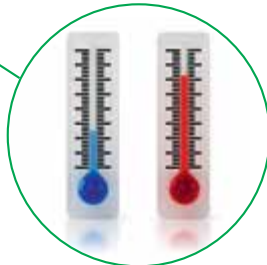

Can be used from -40 °C to +120 °C

Materials contain no halogen or silicone, suitable for many different applications.

	IP66	UL TYPE Rating 12	UL TYPE* Rating 4x
ECOLAB certified	RoHS compliant	Made in Germany	 DNV-GL Approved Products

* 4x is for indoor use only

KDS-SR Modular cable entry system

Frames and inlays	KDS-SR 1-4	KDS-SR 6/10	KDS-SR 8/16	KDS-SR 10/24
				
Diagram	Page 30	Page 30	Page 30	Page 30
Type	KDS-SR 1-4 BK	KDS-SR 6/10 BK	KDS-SR 8/16 BK	KDS-SR 10/24 BK
Cat. no. Qty.	28506.4 1	28500.4 1	28502.4 1	28504.4 1
Description	Screw frame	Screw frame	Screw frame	Screw frame
Type / Set	KDS-Set 1-4 BK	KDS-Set 6/10 BK	KDS-Set 8/16 BK	KDS-Set 10/24 BK
Cat. no. Qty.	28602.4 1	28603.4 1	28604.4 1	28605.4 1
Description	Set consists of: 1 x KDS-SR 1-4 BK, 1 x KDS-Inlay 4 BK	Set consists of: 1 x KDS-SR 6/10 BK, 1 x KDS-Inlay 2 BK, 1 x KDS-Inlay 6 BK	Set consists of: 1 x KDS-SR 8/16 BK, 1 x KDS-Inlay 1 BK, 2 x KDS-Inlay 4 BK	Set consists of: 1 x KDS-Inlay 4 BK, 1 x KDS-Inlay 6 BK
Accessories				
Inlay	KDS-Inlay 1 BK	KDS-Inlay 1 BK	KDS-Inlay 1 BK	KDS-Inlay 1 BK
Cat. no. Qty.	28516.4 5	28516.4 5	28516.4 5	28516.4 5
Description	For separating vertically	For separating vertically	For separating vertically	For separating vertically
Inlay		KDS-Inlay 2 BK		KDS-Inlay 2 BK
Cat. no. Qty.		28517.4 5		28517.4 5
Description		T-shape		T-shape for large small
Inlay	KDS-Inlay 4 BK		KDS-Inlay 4 BK	KDS-Inlay 4 BK
Cat. no. Qty.	28518.4 5		28518.4 5	28518.4 5
Description	for 4-way splits		for 4-way splits	for 4-way splits
Inlay		KDS-Inlay 6 BK		KDS-Inlay 6 BK
Cat. no. Qty.		28519.4 5		28519.4 5
Description		for 6-way splits		for 6-way splits
Inner locking frame (optional)	KDS-IVR 1-4 BK	KDS-IVR 6/10 BK	KDS-IVR 8/16 BK	KDS-IVR 10/24 BK
Cat. no. Qty.	28507.4 10	28501.4 10	28503.4 10	28505.4 10
Sheet-metal hole punch	BL KDS-SR 1-4	BL KDS-SR 6/10	BL KDS-SR 8/16	BL KDS-SR 10/24
Cat. no. Qty.	Page 92	Page 92	Page 92	Page 92
Description	For sheet steel up to 2 mm; also for marking drilling hole points	For sheet steel up to 2 mm; also for marking drilling hole points	For sheet steel up to 2 mm; also for marking drilling hole points	For sheet steel up to 2 mm; also for marking drilling hole points
Actuating tool	KDS BW 1	KDS BW 1	KDS BW 1	KDS BW 1
Cat. no. Qty.	28622.0 1	28622.0 1	28622.0 1	28622.0 1
Seals				
small	KDS-DE	KDS-DE	KDS-DE	KDS-DE
Cat. no. Qty.	Pages 56/57 10	Pages 56/57 10	Pages 56/57 10	Pages 56/57 10
large	KDS-DEG	KDS-DEG	KDS-DEG	KDS-DEG
Cat. no. Qty.	Pages 56/57 10	Pages 56/57 10	Pages 56/57 10	Pages 56/57 10
KDS-DES	KDS-DES	KDS-DES	KDS-DES	KDS-DES
Cat. no. Qty.	Pages 58/59 10	Pages 58/59 10	Pages 58/59 10	Pages 58/59 10
Screw plugs	KDS-VS-SR BK	KDS-VS-SR BK	KDS-VS-SR BK	KDS-VS-SR BK
Mounting screws				
Cat. no. Qty.	28779.4 100	28779.4 100	28779.4 100	28779.4 100

	IP66	UL TYPE Rating 12	UL TYPE* Rating 4x
	RoHS compliant	Made in Germany	 DNV-GL Approved Products



Features

- Material: polyamide PA 6.6, glass-fibre reinforced | TPE
- Colour: black
- Flammability: UL 94 V-0
- Temperature range: -40 °C to +120 °C
- Halogen-free, silicone-free
- Protection: IP66

* 4x is for indoor use only

KDS-SR Combination options

Combination options with KDS-SR 1-4



Combination options with KDS-SR 6/10



Combination options with KDS-SR 8/16



Combination options with KDS-SR 10/24



KDS-FP Flange plates

The new versatile solution for managing cables: The **KDS-FP** flange plate provides machine manufacturers with a very cost-effective, convenient feed-through solution. It can be used to adapt housings and electrical cabinets to fit your updated requirements at any time, and can also considerably simplify your warehousing. You no longer have to stock electrical cabinets or distributors with different configurations of assembled cable and cable outlets. Instead, you can uniformly prepare your products with the flange

plate and then adapt them at any time to your specific cabling or tubing requirements. Your advantage is that you save money by requiring fewer variants.



Your advantages

- Lower costs with increased variability due to standardized opening dimensions
- Guarantee retained for assembled cables
- Versatile, high-density assemblies are possible
- Outstanding IP66 seal
- Integrated strain relief
- Outstanding versatility with optimized warehousing

The basic components of the modular system

Flange plate. Inlays. Seals. The modular design – 3 basic components – provides more versatility, variability and variety.

1. Flange plate

The flange plate is available in the versions **KDS-FP 2x10/24** (up to 20 feed-through openings) or the **KDS-FP 3x10/24** (for up to 20 or 30 openings). Uniform housing cut-outs of 131 mm x 110 mm or 131 mm x 161 mm are used for installation. By screwing the flange plate on the outside of the cabinet, the break-out is completely sealed according to IP66. On the continuous closed plates, there are two or three cover segments with pre-determined breaking points; these can be pushed out (without tools) which then opens up a 110 mm x 40 mm feed-through opening. The click-in KDSClick frame inlays can be used to subdivide this opening in up to ten appropriately sized frame openings.



2 Inlays

The click-in inlays enable needs-based dimensioning of the frame opening, corresponding to the seal being used. An audible "click" confirms a correct installation. So you can variably configure cable entries to match various requirements (for cables, lines, tubing, pneumatic and hydraulic lines).



3. Seals

The conical shape of the sealing elements allows them to be easily pressed in. This also reliably seals the gaps and provides static strain relief in accordance with DIN EN 62444. The seals are installed by pressing them from the inside outwards into the openings of the previously installed inlays. Their wave-cut profile makes them easy to install and ensures a perfect fit around the cables. There are currently over 140 different seals that can be used for sealing cables of various diameters and sizes.



KDS-FP Flange plates

An overview of your advantages

Flange plate is easy to install

The one-piece flange plate can be easily and quickly attached to the wall.



Captive gasket

The foamed-in frame gasket eliminates the risk of incorrect assembly (forgotten gasket) and speeds up the assembly process.



Variability

Can be extended to max. 30 openings, without the use of tools or further machining.



No loss of guarantee: assembled cables

No need to disassemble and reconnect connectors, so manufacturer's warranty is not voided.

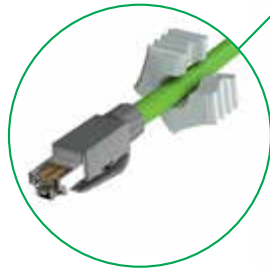

Versatile, high-density assemblies are possible

1-way, 2-way, 3-way and 4-way seals and dummy plugs provide you with excellent versatility for cable management.



Accessories

Locking mechanism can be installed without tools; this provides additional strain relief in direction of cabinet interior.



KDS CLICK

by CONTA-CLIP

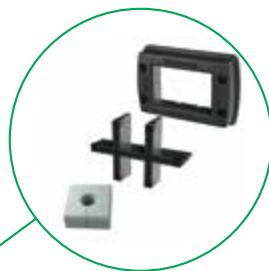
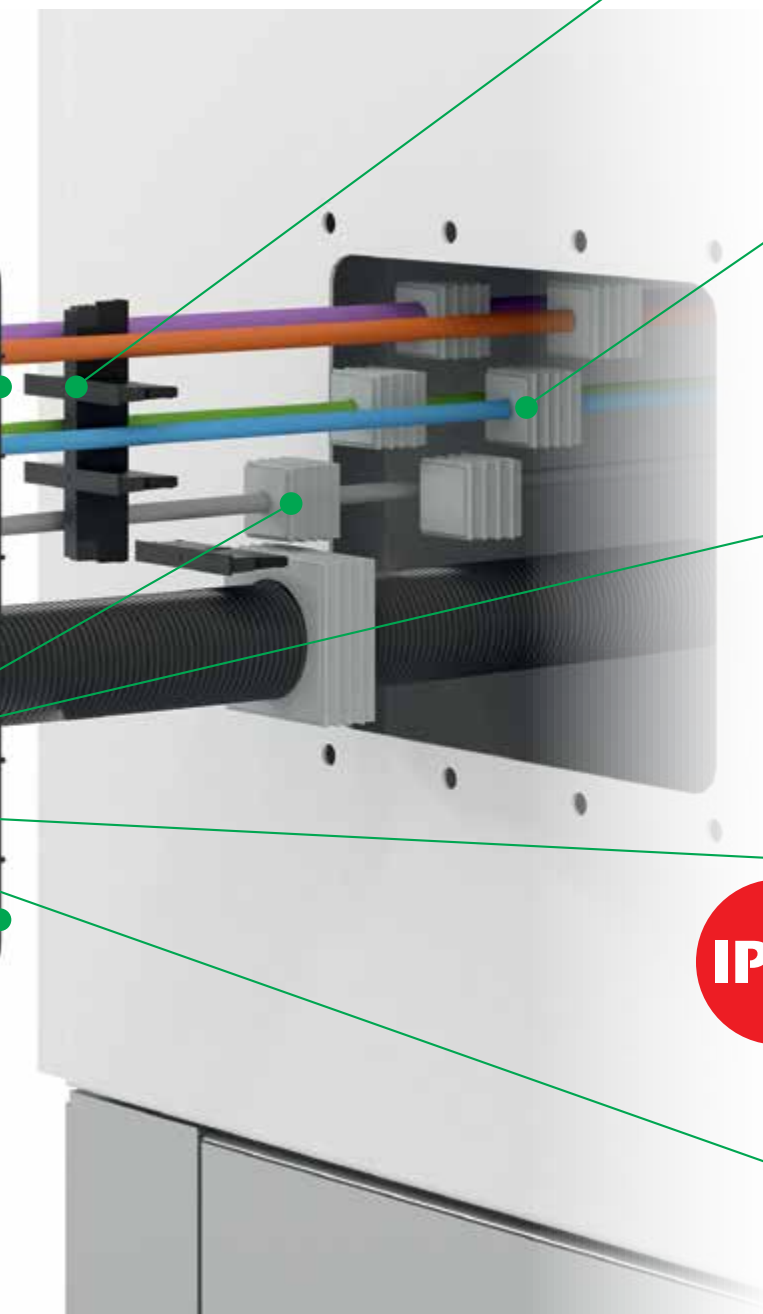

Outstanding versatility with optimized warehousing
The flange plates, inlays and seals can be combined in many ways – ensuring you many versatile configuration options.



Safe and quick installation with feedback
An audible "click" confirms that the inlay has been properly installed in the frame.



Integrated strain relief
The absolute tight fit of the sealing elements also ensures a static strain relief mechanism for the cables according to DIN EN 62444.



Outstanding IP66 seal
Multi-resistant, tapered seals feature inner and outer sealing gills.

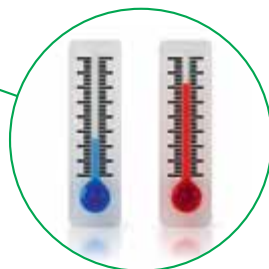

Can be used from -40 °C to +120 °C
Materials contain no halogen or silicone; suitable for many different applications.

	IP66	UL TYPE Rating 12	UL TYPE* Rating 4x
ECOLAB certified	RoHS compliant	Made in Germany	

* 4x is for indoor use only

KDS-FP Flange plates

Flange plates and accessories



KDS-FP 2x10/24



IP66

**UL TYPE
Rating
12**

**UL TYPE*
Rating
4x**

ECOLAB
certified

RoHS
compliant

**Made in
Germany**



* 4x is for indoor use only

Diagram	Page 31	
Type	KDS-FP 2x10/24 BK	
Cat. no.	Qty.	28660.4 1
Description	Flange plate	
Accessories		
Inlay	KDS-Inlay 1 BK	
Cat. no.	Qty.	28516.4 5
Description	For separating vertically	
Inlay	KDS-Inlay 2 BK	
Cat. no.	Qty.	28517.4 5
Description	T-shape for large small	
Inlay	KDS-Inlay 4 BK	
Cat. no.	Qty.	28518.4 5
Description	for 4-way splits	
Inlay	KDS-Inlay 6 BK	
Cat. no.	Qty.	28519.4 5
Description	for 6-way splits	
Inner lock	KDS-FP-IVR OG	
Cat. no.	Qty.	28664.3 20
Inner cover UL	KDS-FP-AD/UL YE	
Cat. no.	Qty.	28665.8 10
Actuating tool	KDS BW 1	
Cat. no.	Qty.	28622.0 1

Flange plates and accessories



KDS-FP 3x10/24 BK



Diagram	Page 31	
Type	KDS-FP 3x10/24 BK	
Cat. no.	Qty.	28661.4 1
Description	Flange plate	
Accessories		
Inlay	KDS-Inlay 1 BK	
Cat. no.	Qty.	28516.4 5
Description	For separating vertically	
Inlay	KDS-Inlay 2 BK	
Cat. no.	Qty.	28517.4 5
Description	T-shape for large small	
Inlay	KDS-Inlay 4 BK	
Cat. no.	Qty.	28518.4 5
Description	for 4-way splits	
Inlay	KDS-Inlay 6 BK	
Cat. no.	Qty.	28519.4 5
Description	for 6-way splits	
Inner lock	KDS-FP-IVR OG	
Cat. no.	Qty.	28664.3 20
Inner cover UL	KDS-FP-AD/UL YE	
Cat. no.	Qty.	28665.8 10
Actuating tool	KDS BW 1	
Cat. no.	Qty.	28622.0 1

KDS-FP Combination options

Combination option 1



KDS-Inlay 4 BK
28518.4



KDS-Inlay 1 BK
28516.4



KDS-Inlay 6 BK
28519.4

Combination option 2



KDS-Inlay 1 BK
28516.4



KDS-Inlay 6 BK
28519.4

Combination option 3



KDS-Inlay 1 BK
28516.4

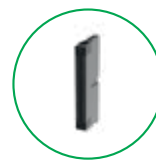

KDS-Inlay 1 BK
28516.4



KDS-Inlay 6 BK
28519.4

Combination option 4



KDS-Inlay 1 BK
28516.4



KDS-Inlay 2 BK
28517.4

Each of the two or three 10-frame openings can be configured with the appropriate inlays to match a wide variety of individual customer requirements.



Features

- Material: polyamide PA 6.6, glass-fibre reinforced | TPE
- Colour: black
- Flammability: UL 94 V-0
- Temperature range: -40 °C to +120 °C
- Halogen-free, silicone-free
- Protection: IP66

KDS-SR

Dimensional diagrams / Mounting cut-outs for the modular cable entry system

KDS-SR 1-4

Dimensional diagram

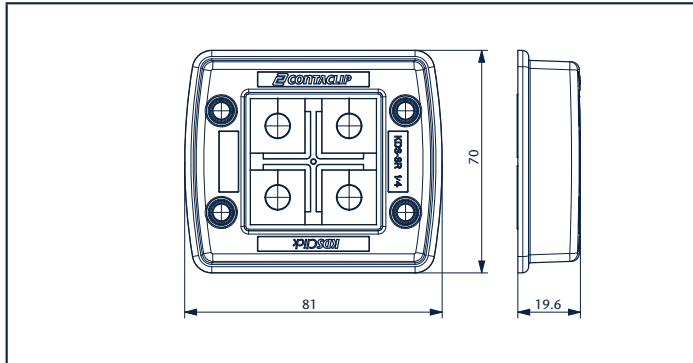

Mounting cut-out

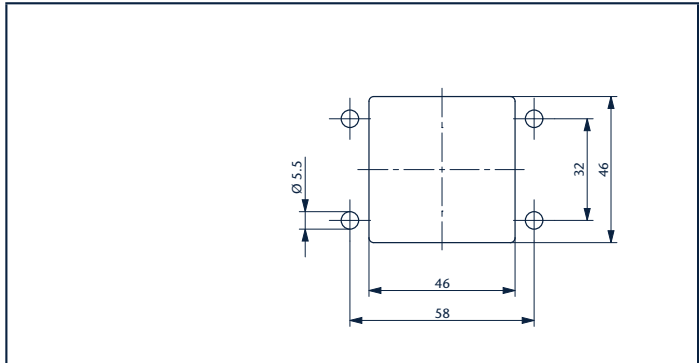

Torque for the frame's mounting screw: 3 Nm

Screw for usage: ISO 4762 / DIN 912

KDS-SR 6/10

Dimensional diagram

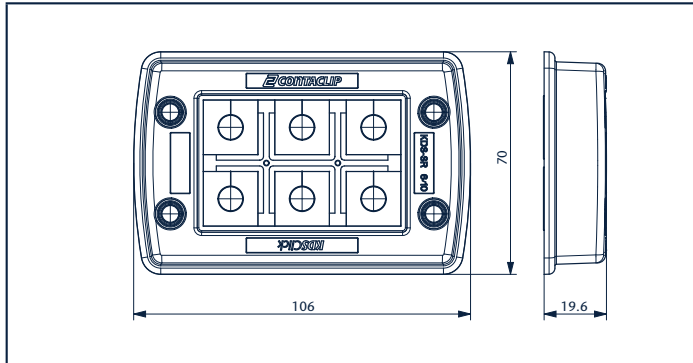

Mounting cut-out

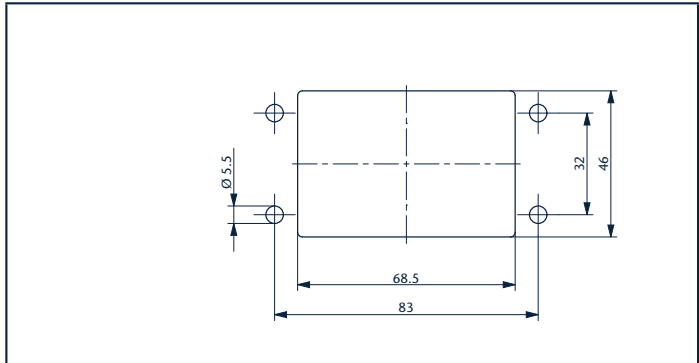

Torque for the frame's mounting screw: 3 Nm

Screw for usage: ISO 4762 / DIN 912

KDS-SR 8/16

Dimensional diagram

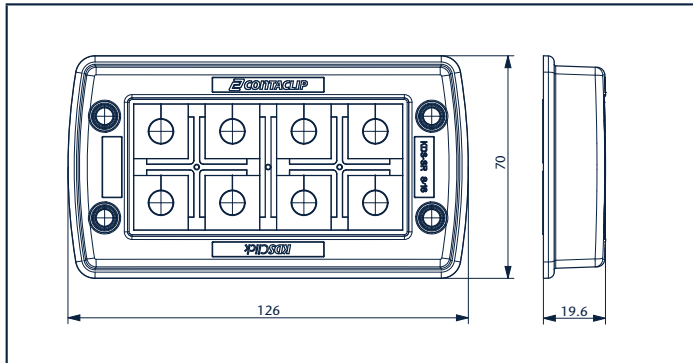

Mounting cut-out

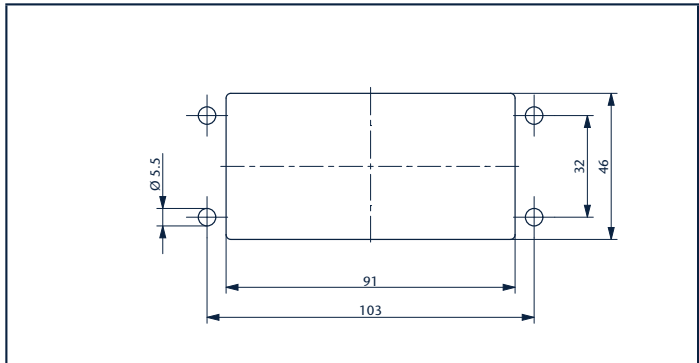

Torque for the frame's mounting screw: 3 Nm

Screw for usage: ISO 4762 / DIN 912

KDS-SR 10/24

Dimensional diagram

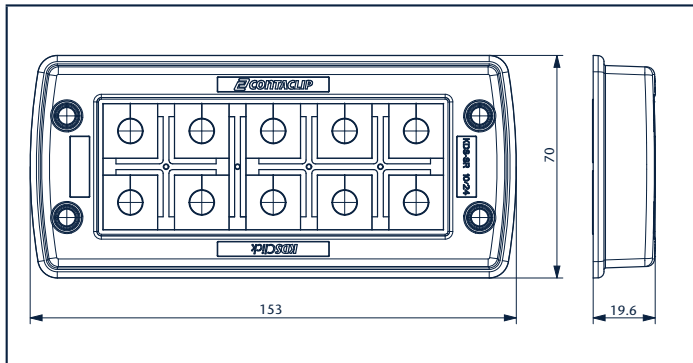

Mounting cut-out

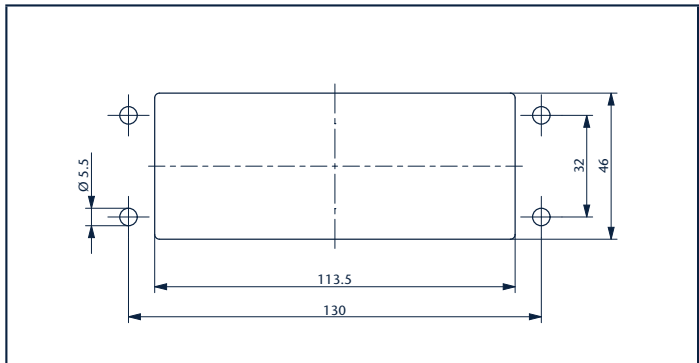

Torque for the frame's mounting screw: 3 Nm

Screw for usage: ISO 4762 / DIN 912

KDS-FP

Dimensional diagrams / Mounting cut-outs for the flange plate

KDS-FP 2x10/24

Dimensional diagram

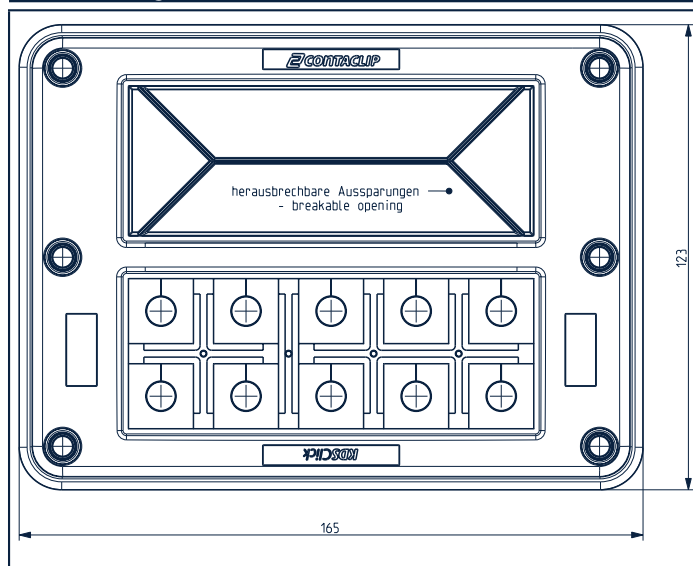

Mounting cut-out

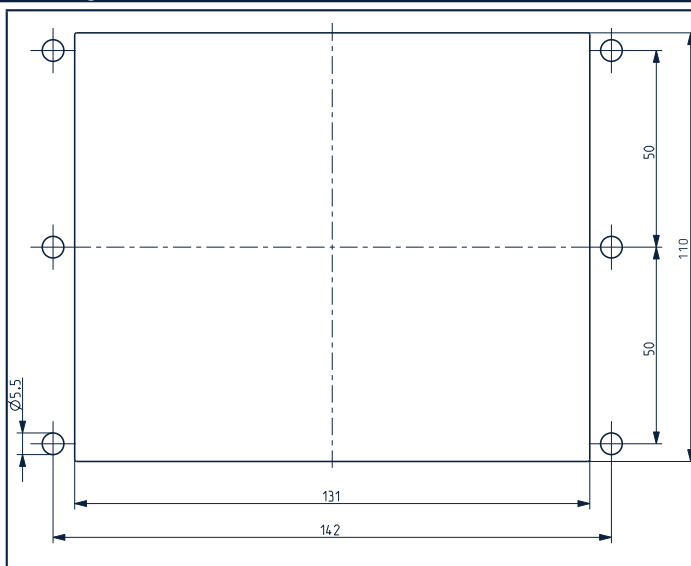

Torque for the frame's mounting screw: 3 Nm

Screw for usage: ISO 4762 / DIN 912

KDS-FP 3x10/24

Dimensional diagram

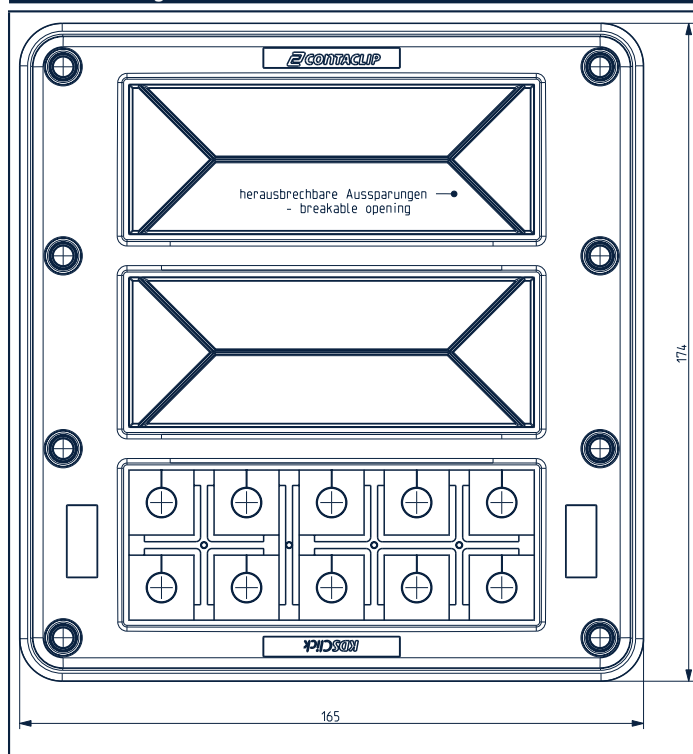

Mounting cut-out

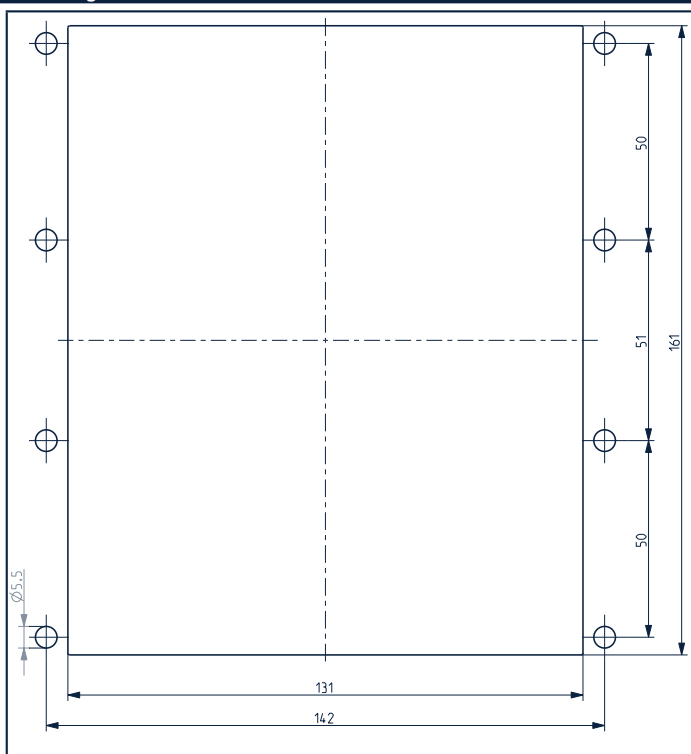

Torque for the frame's mounting screw: 3 Nm

Screw for usage: ISO 4762 / DIN 912

KDS-R

Round cable entries

Overcoming the frame split: Round solutions for your requirements. The round **KDS-R** cable entries for metric cut-outs from M20 to M63 are designed for cables with and without plugs. In case of maintenance or retrofitting with assembled cable harnesses, cables with diameters from 2 mm to 35 mm can be quickly and safely inserted into the electrical cabinets or housings and sealed according to IP66. The modular system ensures quick and easy assembly in three steps. A reliable seal and absolute secure fit is also provided by the slitted, tapered seals with a wave-cut profile, which, after the cables are routed through the cable entry, are placed around the cables and then pressed into the round cable entry.

After that, the separable thread and locking adapter on the electrical cabinet exterior is easily screwed together with the round frame. The separable locknuts that are mounted on the interior of the locking elements ensure safe and secure attachment. This system can be used with a wall thickness up to 6 mm.

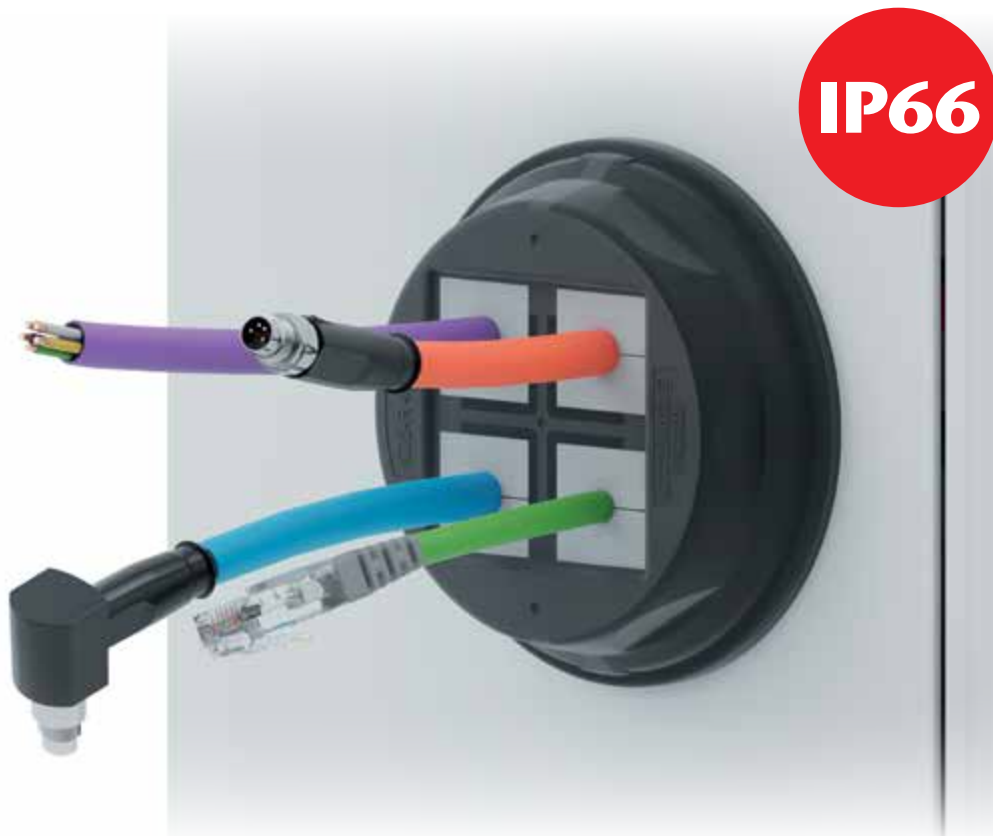

Your advantages

- Assembled cables can be guided through
- Guarantee retained for assembled cables
- Retrofitting and servicing can be done quickly and easily
- High-density assemblies
- Can be installed on standard metric cut-outs
- Protection: IP66

The basic components of the modular system

1. Round cable entries

The round cable entry **KDS-R** ensures quick and secure assembly of hoses and electrical cables in switchboxes and electrical cabinets. The gaskets (TPE) integrated into the cable entry also ensure an outstanding seal in accordance with IP66 on painted and rough surfaces.



2 Inlays

The click-in inlays enable needs-based dimensioning of the frame opening, corresponding to the seal being used. So you can variably configure cable entries to match various requirements (for cables, lines, tubing, pneumatic and hydraulic lines).



3. Thread and locking adapter

The two-piece thread and locking adapter **KDS-RGA** for versatile installation is screwed together with the round cable entry. It locks with a form fit with the cable entry and therefore ensures that the seals and inlays are mechanically secured. The threads located on the electrical cabinet or housing interior are available respectively in six common diameters for metric cut-outs from M20–M32 and M40–M63.



4. Separable locknuts

The individual parts of the locknut **KDS-GM** can be snapped together quickly and easily via the dovetail guide and then can be mounted on the round cable entry.



5. Seals

The tapered shape of the **KDS-DE / KDS-DEG** seal enables user-friendly pressing-in of the seal, reliable sealing of the gaps and ensures a strain relief in accordance with DIN EN 62444. To attach them, the seals are pressed from the inside out into the openings of the cable entries. Their wave-cut profile makes them easy to install and ensures a perfect fit around the cables. There are currently over 140 different seals that can be used for sealing cables of various diameters and sizes.



KDS-R Round cable entries

An overview of your advantages

Mounting

The round cable entry is installed without tools.



Variability

Up to 16 cables can be fed through thanks to the compatibility of the KDS-R 40-63 with the KDS inlay 4.



No loss of guarantee: assembled cables

No need to disassemble and reconnect connectors, so the manufacturer's warranty is not voided.

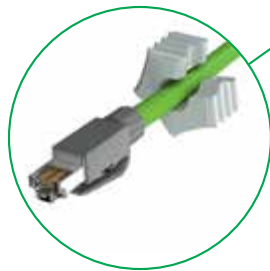

Versatile, high-density assemblies are possible

1-way, 2-way, 3-way and 4-way seals and dummy plugs provide you with excellent versatility for cable management.

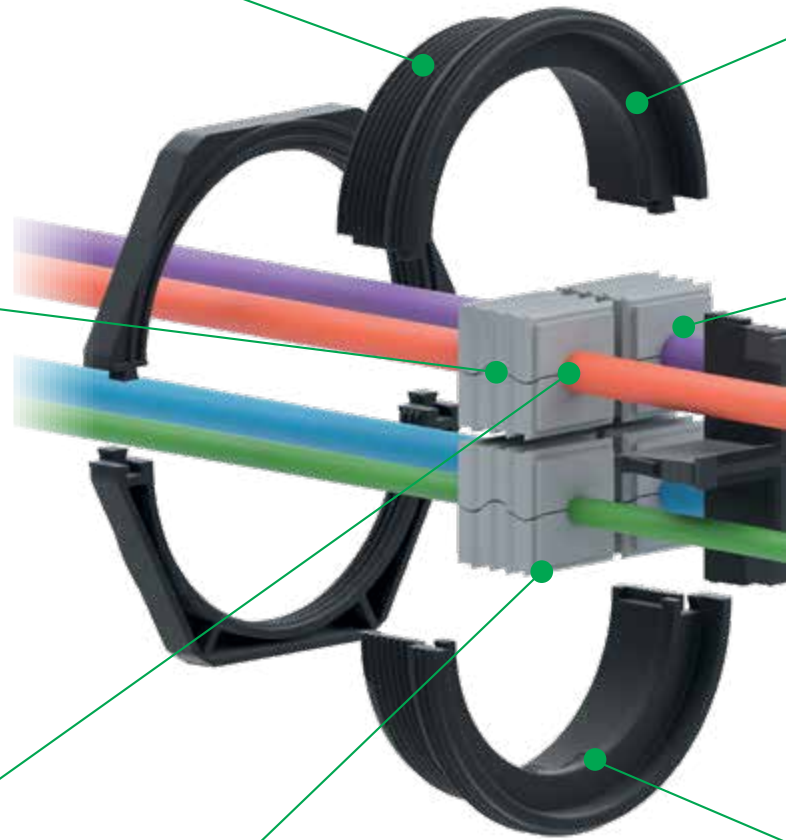



Two round cable entries for six metric break-through sizes

Thanks to six different thread and locking adapters and two external frame sizes, the metric break-through sizes M20 to M32 and M40 to M63 can be equipped with the modular **KSR-R** system. Assembly is carried out from the outside inwards.



Outstanding IP66 seal

Multi-resistant, tapered seals feature inner and outer sealing gills.



Integrated strain relief

The absolute tight fit of the sealing elements also ensures a static strain relief mechanism for the cables according to DIN EN 62444.

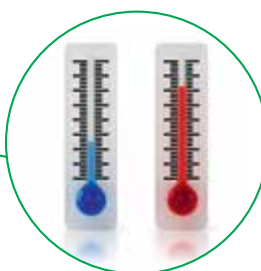

Can be used from -40 °C to +120 °C

Materials contain no halogen or silicone; suitable for many different applications.



Facility availability

Maintenance work is possible during operation due to the separation of the thread adapter and the locknut.



UL TYPE
Rating
12

UL TYPE*
Rating
4x



RoHS
compliant

Made in
Germany



* 4x is for indoor use only

KDS-R

Round cable entries

Round cable entries	KDS-R 20-32	KDS-RGA M20/25/32	KDS-GM 20/25/32
			
Description	Round cable entry	Thread and locking adapter	Separable locknut
Type / colour	KDS-R 20-32 BK	KDS-RGA M20 BK	KDS-GM M20 BK
<i>Cat. no.</i>	28770.4	28771.4	28616.4
Qty.	10	5	10
Type / colour		KDS-RGA M25 BK	KDS-GM M25 BK
<i>Cat. no.</i>		28772.4	28617.4
Qty.		5	10
Type / colour		KDS-RGA M32 BK	KDS-GM M32 BK
<i>Cat. no.</i>		28773.4	28618.4
Qty.		5	10
Cable diameter			
KDS-DE	1-13 mm	1-13 mm	1-13 mm
KDS-DEG			
Accessories			
Thread adapters	KDS-RGA M20 BK		
<i>Cat. no.</i>	28771.4		
Qty.	5		
Thread adapters	KDS-RGA M25 BK		
<i>Cat. no.</i>	28772.4		
Qty.	5		
Thread adapters	KDS-RGA M32 BK		
<i>Cat. no.</i>	28773.4		
Qty.	5		
Locknut		KDS-GM M20 BK	
<i>Cat. no.</i>		28616.4	
Qty.		10	
Locknut		KDS-GM M25 BK	
<i>Cat. no.</i>		28617.4	
Qty.		10	
Locknut		KDS-GM M32 BK	
<i>Cat. no.</i>		28618.4	
Qty.		10	
Inlay			
<i>Cat. no.</i>			
Qty.			
Inlay			
<i>Cat. no.</i>			
Qty.			
Inlay			
<i>Cat. no.</i>			
Qty.			
Actuating tool (refer to page 86)	KDS BW 1		
<i>Cat. no.</i>	28622.0		
Qty.	1		
Sheet-metal hole punch (refer to page 92)		BL KDS-KV M20	
<i>Cat. no.</i>		28746.0	
Qty.		1	
Sheet-metal hole punch (refer to page 92)		BL KDS-KV M25	
<i>Cat. no.</i>		28747.0	
Qty.		1	
Sheet-metal hole punch (refer to page 92)		BL KDS-KV M32	
<i>Cat. no.</i>		28748.0	
Qty.		1	

	UL TYPE Rating 12	UL TYPE* Rating 4x
ECOLAB certified	RoHS compliant	Made in Germany
		

* 4x is for indoor use only

Round cable entries	KDS-R 40-63 BK	KDS-RGA M40/50/63	KDS-GM 40/50/63
			
Description	Round cable entry	Thread and locking adapter	Separable locknut
Type / colour	KDS-R 40-63 BK	KDS-RGA M40 BK	KDS-GM M40 BK
<i>Cat. no.</i>	28774.4	28775.4	28619.4
Qty.	4	5	10
Type / colour		KDS-RGA M50 BK	KDS-GM M50 BK
<i>Cat. no.</i>		28776.4	28620.4
Qty.		5	10
Type / colour		KDS-RGA M63 BK	KDS-GM M63 BK
<i>Cat. no.</i>		28777.4	28621.4
Qty.		5	10
Cable diameter			
KDS-DE	1-13 mm	1-13 mm	1-13 mm
KDS-DEG	14-35 mm	14-35 mm	14-35 mm
Accessories			
Thread adapters	KDS-RGA M40 BK		
<i>Cat. no.</i>	28775.4		
Qty.	5		
Thread adapters	KDS-RGA M50 BK		
<i>Cat. no.</i>	28776.4		
Qty.	5		
Thread adapters	KDS-RGA M63 BK		
<i>Cat. no.</i>	28777.4		
Qty.	5		
Locknut		KDS-GM M40 BK	
<i>Cat. no.</i>		28619.4	
Qty.		10	
Locknut		KDS-GM M50 BK	
<i>Cat. no.</i>		28620.4	
Qty.		10	
Locknut		KDS-GM M63 BK	
<i>Cat. no.</i>		28621.4	
Qty.		10	
Inlay	KDS-Inlay 1 BK		
<i>Cat. no.</i>	28516.4		
Qty.	5		
Inlay	KDS-Inlay 2 BK		
<i>Cat. no.</i>	28517.4		
Qty.	5		
Inlay	KDS-Inlay 4 BK		
<i>Cat. no.</i>	28518.4		
Qty.	5		
Actuating tool (refer to page 86)	KDS BW 1		
<i>Cat. no.</i>	28622.0		
Qty.	1		
Sheet-metal hole punch (refer to page 92)		BL KDS-KV M40	
<i>Cat. no.</i>		28749.0	
Qty.		1	
Sheet-metal hole punch (refer to page 92)		BL KDS-KV M50	
<i>Cat. no.</i>		28750.0	
Qty.		1	
Sheet-metal hole punch (refer to page 92)		BL KDS-KV M63	
<i>Cat. no.</i>		28751.0	
Qty.		1	



Features

- Material: polyamide PA 6.6, glass-fibre reinforced | Gasket: TPE
- Colour: black
- Flammability: UL 94 V-0
- Temperature range: -40 °C to +120 °C
- Halogen-free, silicone-free
- Protection: IP66

Compatibility matrix for round cable entry systems KDS-R

Seals

Grey small		Black small	
Type	Cat. no.	Type	Cat. no.
KDS-DE/B GR	28561.6	KDS-DE/B BK	28520.4
KDS-DE 1.5-2 GR	28562.6	KDS-DE 1.5-2 BK	28521.4
KDS-DE 2-3 GR	28563.6	KDS-DE 2-3 BK	28522.4
KDS-DE 3-4 GR	28564.6	KDS-DE 3-4 BK	28523.4
KDS-DE 4-5 GR	28565.6	KDS-DE 4-5 BK	28524.4
KDS-DE 5-6 GR	28566.6	KDS-DE 5-6 BK	28525.4
KDS-DE 6-7 GR	28567.6	KDS-DE 6-7 BK	28526.4
KDS-DE 7-8 GR	28568.6	KDS-DE 7-8 BK	28527.4
KDS-DE 8-9 GR	28569.6	KDS-DE 8-9 BK	28528.4
KDS-DE 9-10 GR	28570.6	KDS-DE 9-10 BK	28529.4
KDS-DE 10-11 GR	28571.6	KDS-DE 10-11 BK	28530.4
KDS-DE 11-12 GR	28572.6	KDS-DE 11-12 BK	28531.4
KDS-DE 12-13 GR	28573.6	KDS-DE 12-13 BK	28532.4
KDS-DE 13-14 GR	28574.6	KDS-DE 13-14 BK	28533.4
KDS-DE 14-15 GR	28609.6	KDS-DE 14-15 BK	28608.4
KDS-DE 15-16 GR	28671.6	KDS-DE 15-16 BK	28670.4
KDS-DE 2 x 4-5 GR	28595.6	KDS-DE 2 x 4-5 BK	28555.4
KDS-DE 2 x 5-6 GR	28596.6	KDS-DE 2 x 5-6 BK	28556.4
KDS-DE 2 x 6.5 GR	28607.6	KDS-DE 2 x 6.5 BK	28682.4
KDS-DE 4 x 2-3 GR	28597.6	KDS-DE 4 x 2-3 BK	28557.4
KDS-DE 4 x 3-4 GR	28598.6	KDS-DE 4 x 3-4 BK	28558.4
KDS-DE 4 x 4.5 GR	28606.6	KDS-DE 4 x 4.5 BK	28681.4
KDS-DE 4 x 5 GR	28673.6	KDS-DE 4 x 5 BK	28672.4
KDS-DE 4 x 6 GR	28762.6	KDS-DE 4 x 6 BK	28763.4
KDS-DE/1 x ASI GR	28599.6	KDS-DE/1 x ASI BK	28559.4
KDS-DE/2 x ASI GR	28600.6	KDS-DE/2 x ASI BK	28560.4
		KDS-DE/K 2-1 BK	28553.4

Grey large		Black large	
Type	Cat. no.	Type	Cat. no.
KDS-DEG/B GR	28575.6	KDS-DEG/B BK	28534.4
KDS-DEG 14-15 GR	28576.6	KDS-DEG 14-15 BK	28535.4
KDS-DEG 15-16 GR	28577.6	KDS-DEG 15-16 BK	28536.4
KDS-DEG 16-17 GR	28578.6	KDS-DEG 16-17 BK	28537.4
KDS-DEG 17-18 GR	28579.6	KDS-DEG 17-18 BK	28538.4
KDS-DEG 18-19 GR	28580.6	KDS-DEG 18-19 BK	28539.4
KDS-DEG 19-20 GR	28581.6	KDS-DEG 19-20 BK	28540.4
KDS-DEG 20-21 GR	28582.6	KDS-DEG 20-21 BK	28541.4
KDS-DEG 21-22 GR	28583.6	KDS-DEG 21-22 BK	28542.4
KDS-DEG 22-23 GR	28584.6	KDS-DEG 22-23 BK	28543.4
KDS-DEG 23-24 GR	28585.6	KDS-DEG 23-24 BK	28544.4
KDS-DEG 24-25 GR	28586.6	KDS-DEG 24-25 BK	28545.4
KDS-DEG 25-26 GR	28587.6	KDS-DEG 25-26 BK	28546.4
KDS-DEG 26-27 GR	28588.6	KDS-DEG 26-27 BK	28547.4
KDS-DEG 27-28 GR	28589.6	KDS-DEG 27-28 BK	28548.4
KDS-DEG 28-29 GR	28590.6	KDS-DEG 28-29 BK	28549.4
KDS-DEG 29-30 GR	28591.6	KDS-DEG 29-30 BK	28550.4
KDS-DEG 30-31 GR	28592.6	KDS-DEG 30-31 BK	28551.4
KDS-DEG 31-32 GR	28593.6	KDS-DEG 31-32 BK	28552.4
KDS-DEG 32-33 GR	28594.6	KDS-DEG 32-33 BK	28601.4
KDS-DEG 33-34 GR	28731.6	KDS-DEG 33-34 BK	28730.4
KDS-DEG 34-35 GR	28733.6	KDS-DEG 34-35 BK	28732.4

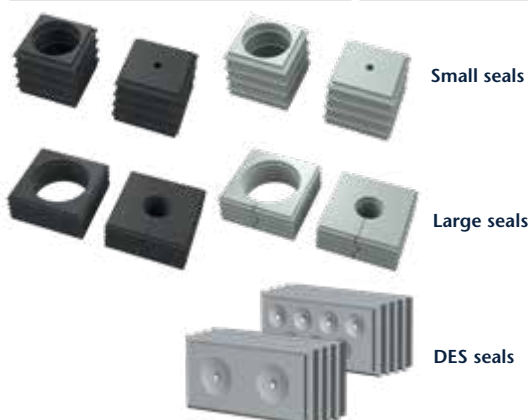

KDS-DES	
Type	Cat. no.
KDS-DES 2X10.5 GR	28800.6
KDS-DES 3X9.5 GR	28801.6
KDS-DES 3X8.5 GR	28802.6
KDS-DES 4X7.5 GR	28803.6
KDS-DES 7X6.5 GR	28804.6
KDS-DES 8X5.5 GR	28805.6
KDS-DES 8X4.5 GR	28806.6
KDS-DE-FB1/A GR	28713.6
KDS-DE-FB1/B GR	28714.6
KDS-DE-FB1/C GR	28715.6
KDS-DE-FB1/D GR	28716.6
KDS-DE-FB1/E GR	28717.6
KDS-DE-FB1/F GR	28718.6

KDS-KV

Separable cable glands

All-round "cornered" solutions for your requirements! All-round "cornered" solutions for your requirements! For metric cut-outs from M20 to M63, CONTA-CLIP provides the **KDS-KV** separable cable glands for cables with or without attached plugs. In case of maintenance or retrofitting with assembled cable harnesses, cables with diameters from 2 mm to 35 mm can be quickly and safely inserted into the electrical cabinets or housings and sealed according to IP66. This separable system ensures quick and simple installation. The slitted seal has a wave-cut profile that ensures a reliable seal and a totally secure attach-

ment. The seal is first placed around the cable and then inserted in one of the two halves of the cable gland. After inserting the seals, the two halves of the cable gland are simply snapped together. A locknut (which can also be separated) on the inside of the cabinet ensures a safe and secure attachment.



Your advantages

- Assembled cables can be guided through
- Guarantee retained for assembled cables
- Retrofitting and servicing can be done quickly and easily
- High-density assemblies
- Can be installed on standard metric cut-outs
- Includes a separable hexagon nut

The basic components of the modular system

1. Split cable glands

Consisting of two half-shells, the cable gland is quick and easy to install. It is made of dimensionally stable, glass-fibre reinforced plastic. The integrated gasket guarantees an optimal seal with IP66 protection, even on painted or rough surfaces.



2 Separable locknuts

The individual parts of the locknut can be snapped together quickly and easily via the dovetail guide and then mounted with the gland.



3. Seals

The conical shape of the sealing elements allows them to be easily pressed in. This also reliably seals the gaps and provides static strain relief in accordance with DIN EN 62444. The seals are installed by pressing them from the inside outwards into the openings of the previously installed inlays. Their wave-cut profile makes them easy to install and ensures a perfect fit around the cables. There are currently over 140 different seals that can be used for sealing cables of various diameters and sizes.



KDS-KV Separable cable glands

An overview of your advantages

Mounting

No tools are required to mount the cable gland.



Variability

Up to 4 cables can be fed through using just one cable gland.

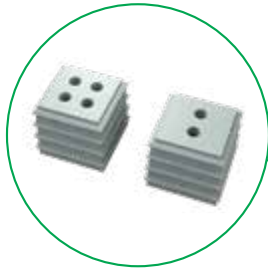

No loss of guarantee: assembled cables

No need to disassemble and re-connect connectors, so the manufacturer's warranty is not voided.

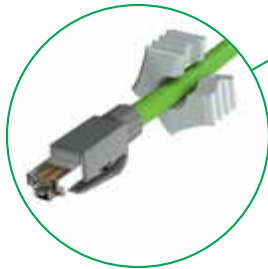

Versatile, high-density assemblies are possible

1-way, 2-way, 3-way and 4-way seals and dummy plugs provide you with excellent versatility for cable management.

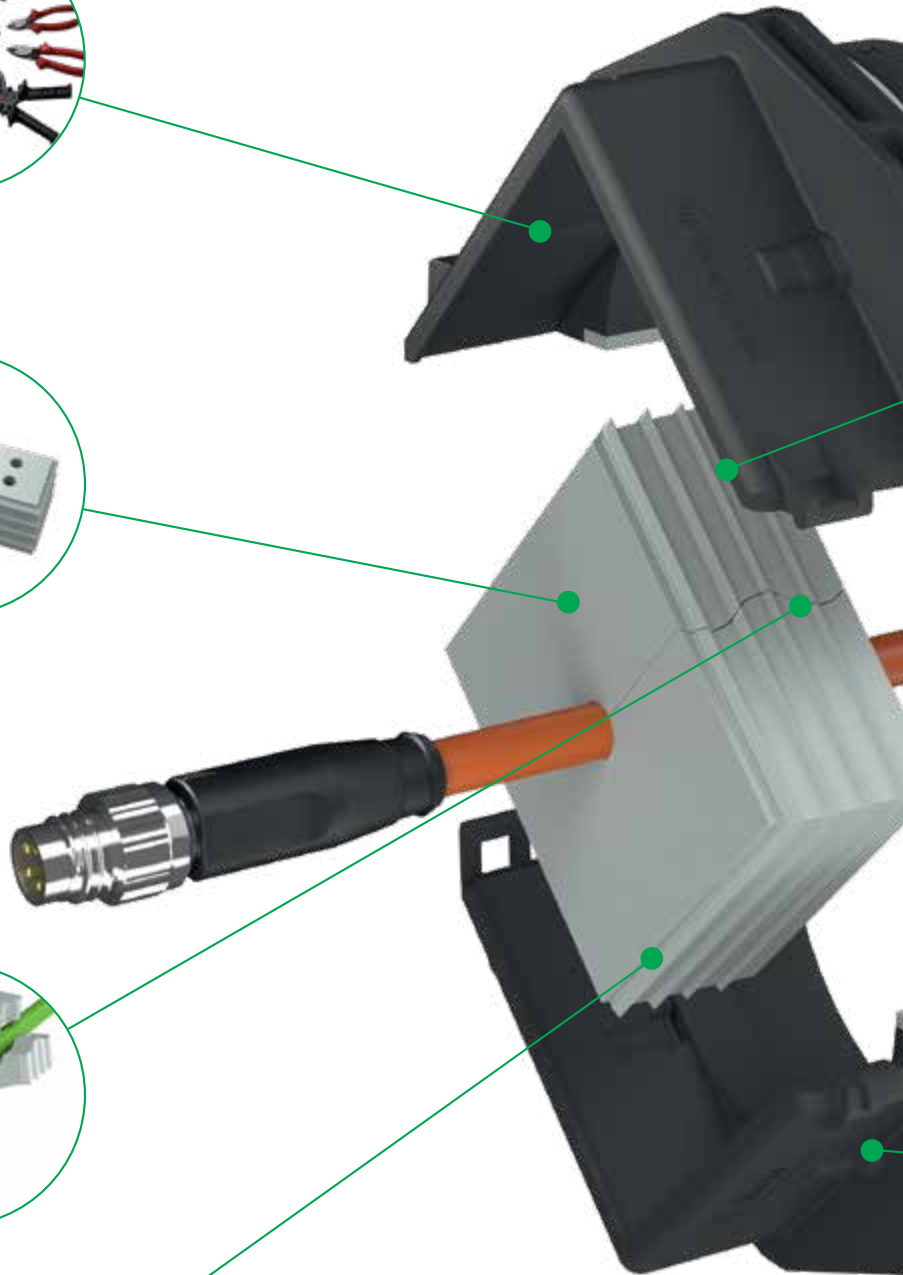
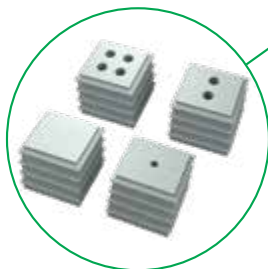



Outstanding seal

Multi-resistant, tapered seals feature inner and outer sealing gills.

Integrated strain relief

The absolute tight fit of the sealing elements also ensures a static strain relief mechanism for the cables according to DIN EN 62444.

Facility availability

Since the cable gland and the lock-nut are separable, servicing can be carried out during operations.

Can be used from -40 °C to +120 °C

Materials contain no halogen or silicone; suitable for many different applications.

KDS-KV

Separable cable glands

Separable cable glands		KDS-KV M20	KDS-KV M25	KDS-KV M32
				
Diagram				
Type		KDS-KV M20 BK	KDS-KV M25 BK	KDS-KV M32 BK
Cat. no.	Qty.	28610.4	28611.4	28612.4
Description		Separable cable gland, including separable locknut	Separable cable gland, including separable locknut	Separable cable gland, including separable locknut
Cable diameter, mm				
KDS-DE		1–13 mm	1–14 mm	1–14 mm
Accessories				
Locknut		KDS-GM 20 BK	KDS-GM 25 BK	KDS-GM 32 BK
Cat. no.	Qty.	28616.4	28617.4	28618.4
Description		Separable locknut	Separable locknut	Separable locknut
Seals				
small		KDS-DE	KDS-DE	KDS-DE
Cat. no.	Qty.	Pages 56 – 59	Pages 56 – 59	Pages 56 – 59
Tightening torque of lock nut, in Nm		4	4	4
Combinations				
				
Accessories				
Sheet-metal hole punch (refer to page 92)		BL KDS-KV M20	BL KDS-KV M25	BL KDS-KV M32
Cat. no.	Qty.	28746.0	28747.0	28748.0

Separable cable glands		KDS-KV M40	KDS-KV M50	KDS-KV M63	
					
Diagram					
Type		KDS-KV M40 BK	KDS-KV M50 BK	KDS-KV M63 BK	
Cat. no.	Qty.	28613.4	5	28614.4	5
Description		Separable cable gland, including separable locknut	Separable cable gland, including separable locknut	Separable cable gland, including separable locknut	
Cable diameter, mm		14–33 mm	14–33 mm	14–33 mm	
Accessories					
Locknut		KDS-GM 40 BK	KDS-GM 50 BK	KDS-GM 63 BK	
Cat. no.	Qty.	28619.4	5	28620.4	5
Description		Separable locknut	Separable locknut	Separable locknut	
Seals					
small		KDS-DEG	KDS-DEG	KDS-DEG	
Cat. no.	Qty.	Pages 56 – 59	Pages 56 – 59	Pages 56 – 59	
Tightening torque of lock nut, in Nm		7	7	7	
Combinations					
					
Accessories					
Sheet-metal hole punch (refer to page 92)		BL KDS-KV M40	BL KDS-KV M50	BL KDS-KV M63	
Cat. no.	Qty.	28749.0	1	28750.0	1
				28751.0	1



Features

- Material: polyamide PA 6.6, glass-fibre reinforced | Gasket: TPE
- Colour: black
- Flammability: UL 94 V-0
- Temperature range: -40 °C to +120 °C
- Halogen-free, silicone-free
- Protection: IP66

KDS-FB

Cable entry system for flat cables

Supported by:



on the basis of a decision
by the German Bundestag

Fast. Safe. Turning cables inside out! The **KDS-FB** cable entry system for flat cables provides you with outstanding versatility and saves you time while managing cables, especially for industrial trucks, crane systems and elevator applications. The "fish skin" on the seal

mechanically surrounds the inserted flat cable; this ensures outstanding tolerance compensation and IP66 protection.

Attaching the frame

Made from a single mould, the one-piece frame is quick and easy to assemble. It is made of sturdy, glass-fibre reinforced plastic.



Quickly assembled from the inside out

The frame does not need to be disassembled if your requirements change or if you're carrying out service work.



Captive gasket

The moulded-in frame gasket eliminates the risk of incorrect assembly (forgotten gasket) and speeds up the assembly process.



Seals

The seals' conical shape enables them to be easily pressed in so they can seal gaps. To attach them, the seals are pressed from the inside out into the openings. There are currently over 140 different seals that can be used for sealing cables of various diameters and sizes.

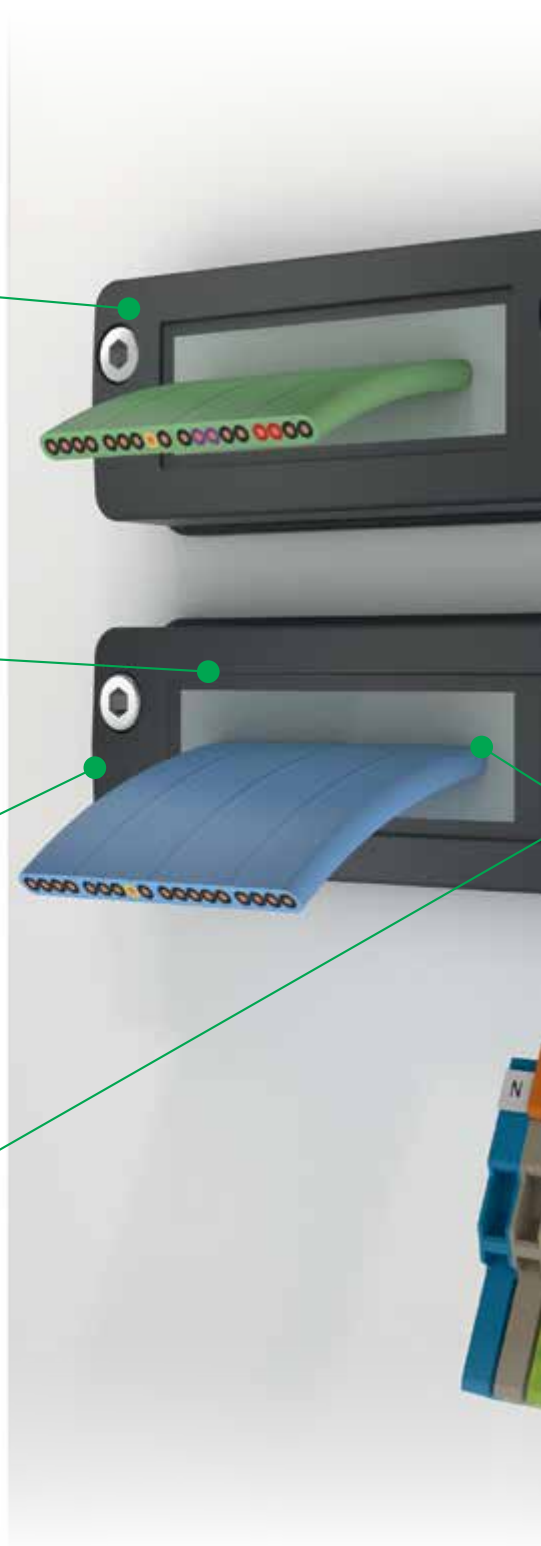
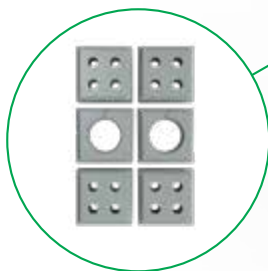

IP66

RoHS
compliant

Made in
Germany



Your advantages

30 % less time required for new installations because of the one-piece frame. Modifications, retrofits, service work or the readjustment of cable lengths can be made at any time without disassembling the frame, since the seals are released from the outside inwards by simply pressing in.

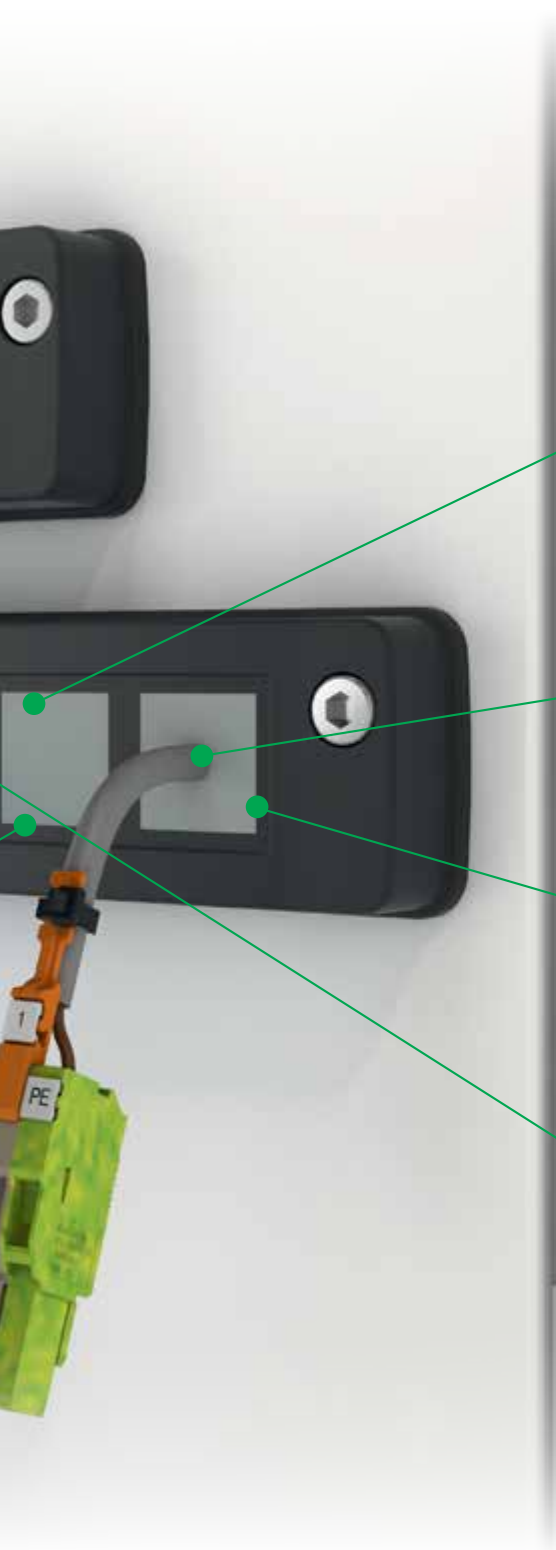

Versatile, high-density assemblies are possible

1-way, 2-way, 3-way and 4-way seals and dummy plugs provide you with excellent versatility for cable management.



Outstanding IP66 seal

Multi-resistant, tapered seals feature inner and outer sealing gills.

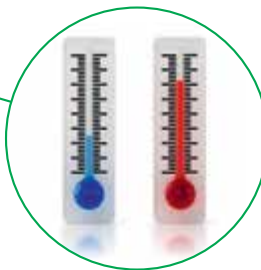

Can be used from -40 °C to +120 °C

Materials contain no halogen or silicone, suitable for many different applications.

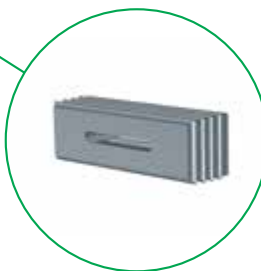

Fish skin

The "fish skin" mechanically surrounds the inserted flat cable; this ensures outstanding tolerance compensation and IP66 protection.

KDS-FB

Cable entry system for flat cables

Frame	KDS-SR-FB1/A	KDS-SR-FB2/A	KDS-SR-FB2/B
			
Diagram	Page 42	Page 42	Page 42
Type / colour	KDS-SR-FB1/A BK	KDS-SR-FB2/A BK	KDS-SR-FB2/B BK
Cat. no.	28700.4	28701.4	28702.4
Qty.	10	10	10
Seals (refer to pages 56 – 57, or pages 52 – 53)			
KDS-DE ...			1 x
KDS-DE-FB1	1 x		1 x
KDS-DE-FB2		1 x	
KDS-DE-FB3			
KDS-DE-FB4			
Accessories			
Actuating tool (refer to page 86)	KDS BW 1	KDS BW 1	KDS BW 1
Cat. no.	28622.0	28622.0	28622.0
Qty.	1	1	1
Sheet-metal hole punch (refer to page 92)	BL-VA KDS-FB1	BL-VA KDS-FB2	BL-VA KDS-FB2
Cat. no.	28729.0	28741.0	28741.0
Qty.	1	1	1

Frame	KDS-SR-FB4/A	KDS-SR-FB4/B	KDS-SR-FB4/C
			
Diagram	Page 43	Page 43	Page 43
Type / colour	KDS-SR-FB4/A BK	KDS-SR-FB4/B BK	KDS-SR-FB4/C BK
Cat. no.	28707.4	28708.4	28709.4
Qty.	10	10	10
Seals (refer to pages 56 – 57, or pages 52 – 53)			
KDS-DE ...		2 x	1 x
KDS-DE-FB1			2 x
KDS-DE-FB2		1 x	
KDS-DE-FB3			
KDS-DE-FB4	1 x		
Accessories			
Actuating tool (refer to page 86)	KDS BW 1	KDS BW 1	KDS BW 1
Cat. no.	28622.0	28622.0	28622.0
Qty.	1	1	1
Sheet-metal hole punch (refer to page 92)	BL-VA KDS-FB4	BL-VA KDS-FB4	BL-VA KDS-FB4
Cat. no.	28743.0	28743.0	28743.0
Qty.	1	1	1



Features

- Material: polyamide PA 6.6, glass-fibre reinforced | TPE
- Colour: black
- Flammability: UL 94 V-0
- Temperature range: -40 °C to +120 °C
- Halogen-free, silicone-free
- Protection: IP66



Page 43	Page 43	Page 43	Page 43
KDS-SR-FB3/A BK 28703.4	KDS-SR-FB3/B BK 28704.4	KDS-SR-FB3/C BK 28705.4	KDS-SR-FB3/D BK 28706.4
10	10	10	10
	1 x		2 x
	1 x	2 x	1 x
1 x			

KDS BW 1 28622.0	KDS BW 1 28622.0	KDS BW 1 28622.0	KDS BW 1 28622.0
1	1	1	1
BL-VA KDS-FB3 28742.0	BL-VA KDS-FB3 28742.0	BL-VA KDS-FB3 28742.0	BL-VA KDS-FB3 28742.0
1	1	1	1



Page 43	Page 43	Page 43
KDS-SR-FB4/D BK 28710.4	KDS-SR-FB4/E BK 28711.4	KDS-SR-FB4/F BK 28712.4
10	10	10
3 x		5 x
1 x	1 x	
	1 x	

KDS BW 1 28622.0	KDS BW 1 28622.0	KDS BW 1 28622.0
1	1	1
BL-VA KDS-FB4 28743.0	BL-VA KDS-FB4 28743.0	BL-VA KDS-FB4 28743.0
1	1	1

IP66	RoHS compliant	Made in Germany	
-------------	--------------------------	--------------------	---

KDS-FB

Dimensional diagrams / Mounting cut-outs

KDS-SR-FB1

Dimensional diagram

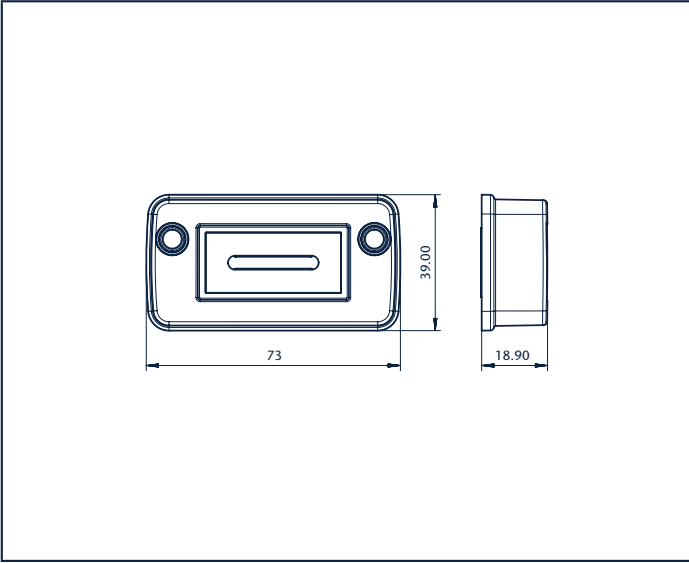

Torque for the frame's mounting screw: 3 Nm

Mounting cut-out

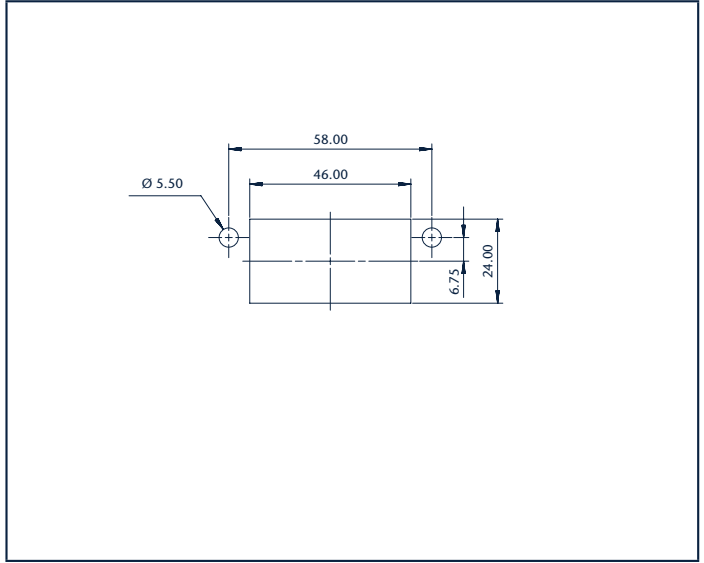

Screw for usage: ISO 4762 / DIN 912

KDS-SR-FB2

Dimensional diagram

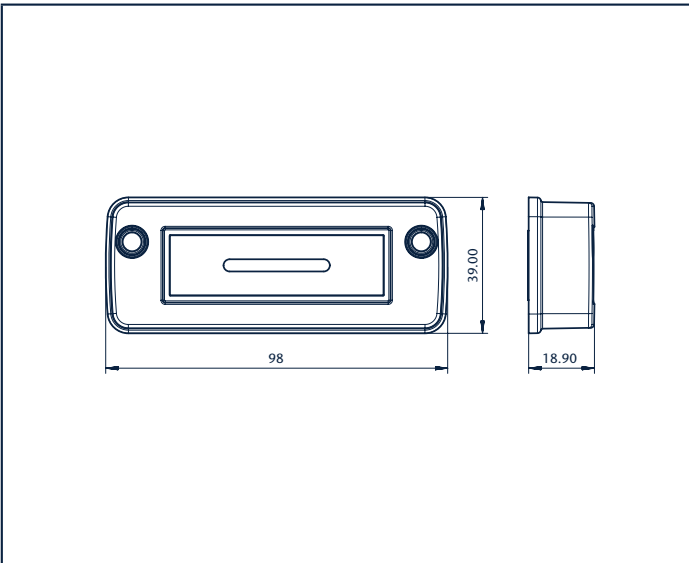

Torque for the frame's mounting screw: 3 Nm

Mounting cut-out

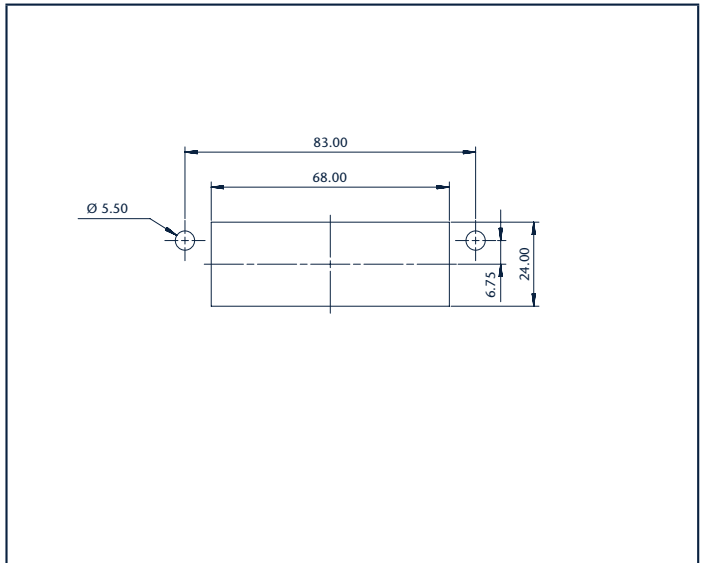

Screw for usage: ISO 4762 / DIN 912

KDS-SR-FB3

Dimensional diagram

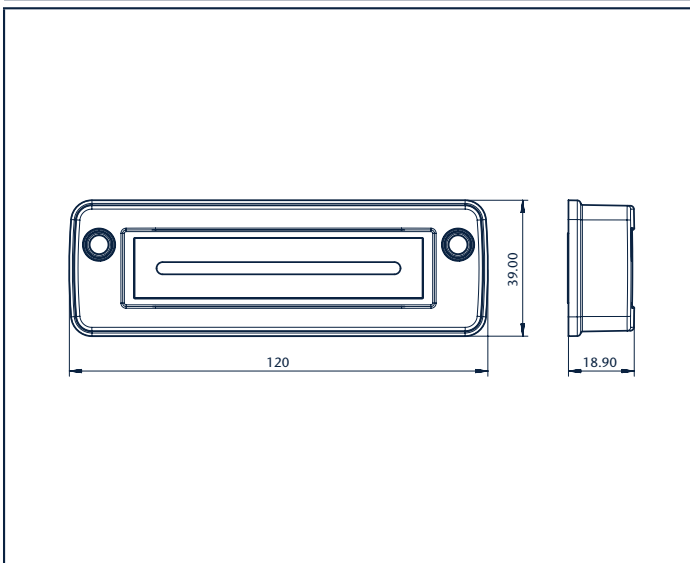

Torque for the frame's mounting screw: 3 Nm

Mounting cut-out

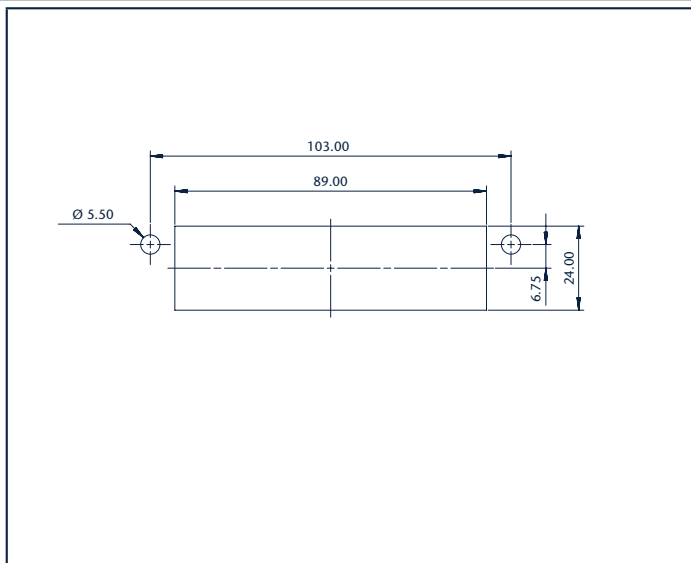

Screw for usage: ISO 4762 / DIN 912

KDS-SR-FB4

Dimensional diagram

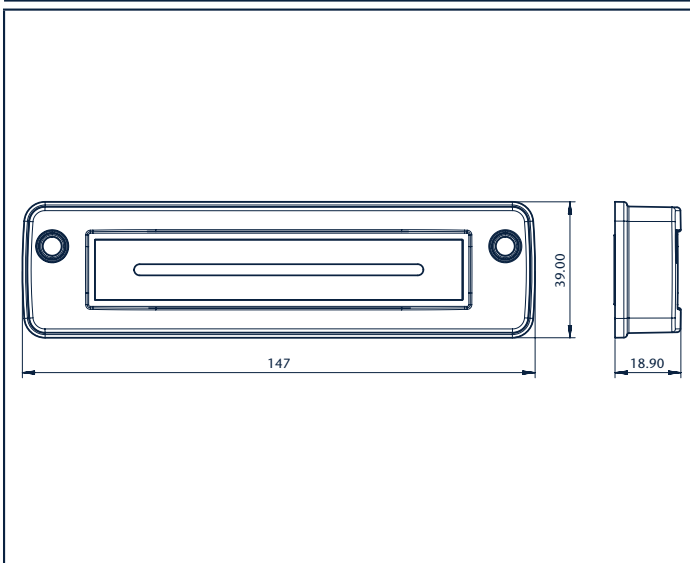



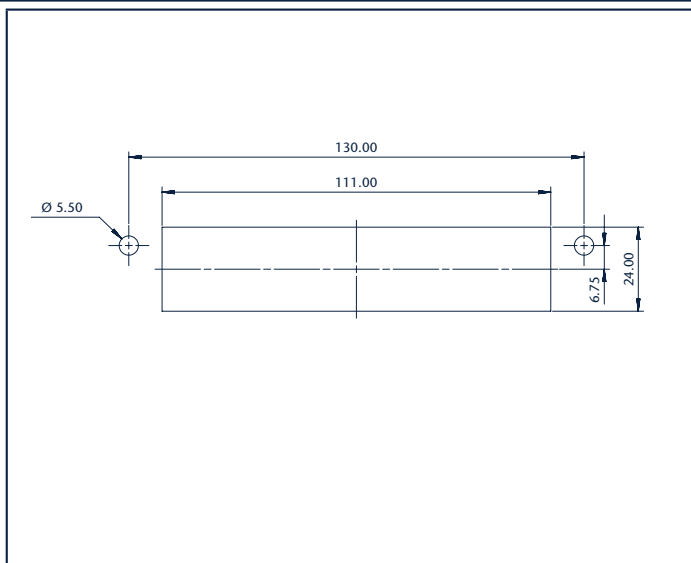

Torque for the frame's mounting screw: 3 Nm





Mounting cut-out







Screw for usage: ISO 4762 / DIN 912

Seals for KDS-FB

Seals		KDS-DE-FB1/A	KDS-DE-FB1/B	KDS-DE-FB1/C	
					
Type / colour		KDS-DE-FB1/A GR	KDS-DE-FB1/B GR	KDS-DE-FB1/C GR	
Cat. no.	Qty.	28713.6	5	28714.6	5
Sealing area			Width: 19–23 mm Thickness: 5.5–6 mm	Width: 28–33 mm Thickness: 5.5–6 mm	

Seals		KDS-DE-FB2/B	KDS-DE-FB2/C	KDS-DE-FB2/D	
					
Type / colour		KDS-DE-FB2/B GR	KDS-DE-FB2/C GR	KDS-DE-FB2/D GR	
Cat. no.	Qty.	28720.6	5	28721.6	5
Sealing area		Width: 32.5–38 mm Thickness: 5–5.5 mm	Width: 45–50.5 mm Thickness: 6–6.5 mm	Width: 47–52 mm Thickness: 9.5–10 mm	

Seals		KDS-DE-FB3/C	KDS-DE-FB4/A	KDS-DE-FB4/B	
					
Type / colour		KDS-DE-FB3/C GR	KDS-DE-FB4/A GR	KDS-DE-FB4/B GR	
Cat. no.	Qty.	28739.6	5	28727.6	5
Sealing area		Width: 64–69 mm Thickness: 11–12 mm		Width: 85–90 mm Thickness: 4.2–5.2 mm	



Features







- Material: TPE
- Flammability: UL 94 V-0
- Temperature range: -40 °C to +90 °C (static)
- Halogen-free, silicone-free
- Protection: IP66

KDS-DE-FB1/D	KDS-DE-FB1/E	KDS-DE-FB1/F	KDS-DE-FB2/A
			
KDS-DE-FB1/D GR 28716.6 5 Width: 24 – 30 mm Thickness: 8.5 – 9 mm	KDS-DE-FB1/E GR 28717.6 5 Width: 19 – 24 mm Thickness: 6.5 – 7 mm	KDS-DE-FB1/F GR 28718.6 5 Width: 28 – 33 mm Thickness: 9 – 9.5 mm	KDS-DE-FB2/A GR 28719.6 5
KDS-DE-FB2/E	KDS-DE-FB2/F	KDS-DE-FB3/A	KDS-DE-FB3/B
			
KDS-DE-FB2/E GR 28723.6 5 Width: 38 – 43 mm Thickness: 12.5 – 13 mm	KDS-DE-FB2/F GR 28724.6 5 Width: 49 – 54 mm Thickness: 5 – 6 mm	KDS-DE-FB3/A GR 28725.6 5	KDS-DE-FB3/B GR 28726.6 5 Width: 72 – 77 mm Thickness: 5 – 5.5 mm
KDS-DE-FB4/C			
			
KDS-DE-FB4/C GR 28740.6 5 Width: 94 – 99 mm Thickness: 4.2 – 5.2 mm			

IP66	RoHS compliant	Made in Germany	
-------------	--------------------------	--------------------	---

Cat. no.	KDS-SR-FB1/A BK 28700.4	KDS-SR-FB2/A BK 28701.4	KDS-SR-FB2/B BK 28702.4	KDS-SR-FB3/A BK 28703.4	KDS-SR-FB3/B BK 28704.4	KDS-SR-FB3/C BK 28705.4

* An overview of all seals with the external dimensions 20 x 20 can be found on pages 56 – 57.

KDS-SR-FB3/D BK 28706.4	KDS-SR-FB4/A BK 28707.4	KDS-SR-FB4/B BK 28708.4	KDS-SR-FB4/C BK 28709.4	KDS-SR-FB4/D BK 28710.4	KDS-SR-FB4/E BK 28711.4	KDS-SR-FB4/F BK 28712.4
						
•		•	•	•		•
•		•		•	•	
•		•		•	•	
•		•		•	•	
•		•		•	•	
•		•		•	•	
			•		•	
			•		•	
			•		•	
			•		•	
			•		•	
			•		•	
			•		•	
	•					
	•					
	•					

Sealing elements KDS systems

Seals	Grey small		
	Type	Cat. no.	Qty. Max. Ø
	KDS-DE/B GR	28561.6	10 Blind
	KDS-DE 1.5 GR	28694.6	10 1.5 mm
	KDS-DE 1.5-2 GR	28562.6	10 2 mm
	KDS-DE 2 GR	28696.6	10 2 mm
	KDS-DE 2-3 GR	28563.6	10 3 mm
	KDS-DE 3 GR	28698.6	10 3 mm
	KDS-DE 3-4 GR	28564.6	10 4 mm
	KDS-DE 4-5 GR	28565.6	10 5 mm
	KDS-DE 5-6 GR	28566.6	10 6 mm
	KDS-DE 6-7 GR	28567.6	10 7 mm
	KDS-DE 7-8 GR	28568.6	10 8 mm
	KDS-DE 8-9 GR	28569.6	10 9 mm
	KDS-DE 9-10 GR	28570.6	10 10 mm
	KDS-DE 10-11 GR	28571.6	10 11 mm
	KDS-DE 11-12 GR	28572.6	10 12 mm
	KDS-DE 12-13 GR	28573.6	10 13 mm
KDS-DE 13-14 GR	28574.6	10 14 mm	
KDS-DE 14-15 GR	28609.6	10 15 mm	
KDS-DE 15-16 GR	28671.6	10 16 mm	
Seals	Grey large		
	KDS-DEG/B GR	28575.6	10 Blind
	KDS-DEG 14-15 GR	28576.6	10 15 mm
	KDS-DEG 15-16 GR	28577.6	10 16 mm
	KDS-DEG 16-17 GR	28578.6	10 17 mm
	KDS-DEG 17-18 GR	28579.6	10 18 mm
	KDS-DEG 18-19 GR	28580.6	10 19 mm
	KDS-DEG 19-20 GR	28581.6	10 20 mm
	KDS-DEG 20-21 GR	28582.6	10 21 mm
	KDS-DEG 21-22 GR	28583.6	10 22 mm
	KDS-DEG 22-23 GR	28584.6	10 23 mm
	KDS-DEG 23-24 GR	28585.6	10 24 mm
	KDS-DEG 24-25 GR	28586.6	10 25 mm
	KDS-DEG 25-26 GR	28587.6	10 26 mm
	KDS-DEG 26-27 GR	28588.6	10 27 mm
	KDS-DEG 27-28 GR	28589.6	10 28 mm
	KDS-DEG 28-29 GR	28590.6	10 29 mm
	KDS-DEG 29-30 GR	28591.6	10 30 mm
	KDS-DEG 30-31 GR	28592.6	10 31 mm
	KDS-DEG 31-32 GR	28593.6	10 32 mm
KDS-DEG 32-33 GR	28594.6	10 33 mm	
KDS-DEG 33-34 GR	28731.6	10 34 mm	
KDS-DEG 34-35 GR	28733.6	10 35 mm	
Seals with multiple holes	Grey multiple		
	KDS-DE 2x4-5 GR	28595.6	10 5 mm
	KDS-DE 2x5-6 GR	28596.6	10 6 mm
	KDS-DE 2x6.5 GR	28607.6	10 6.5 mm
	KDS-DE 2x7 GR	28690.6	10 7 mm
	KDS-DE 2x8 GR	28692.6	10 8 mm
	KDS-DE 3x5-6 GR	28688.6	10 6 mm
	KDS-DE 4x2-3 GR	28597.6	10 3 mm
	KDS-DE 4x3-4 GR	28598.6	10 4 mm
	KDS-DE 4x4.5 GR	28606.6	10 4.5 mm
	KDS-DE 4x5 GR	28673.6	10 5 mm
KDS-DE 4x6 GR	28762.6	10 6 mm	
Seals for AS interface cables	Grey		
	KDS-DE/1xASI GR	28599.6	10
	KDS-DE/2xASI GR	28600.6	10



IP66

UL TYPE
Rating
12UL TYPE*
Rating
4xECOLAB
certifiedRoHS
compliantMade in
GermanyDNV-GL
Approved
Products

Features

- Material: TPE
- Flammability: UL 94 V-0
- Temperature range: -40 °C to +90 °C (static)
- Halogen-free, silicone-free
- Protection: IP66

* 4x is for indoor use only

Seals	Black small			
	Type	Cat. no.	Qty.	Max. Ø
	KDS-DE/B BK	28520.4	10	Blind
	KDS-DE 1.5 BK	28693.4	10	1.5 mm
	KDS-DE 1.5-2 BK	28521.4	10	2 mm
	KDS-DE 2 BK	28695.4	10	2 mm
	KDS-DE 2-3 BK	28522.4	10	3 mm
	KDS-DE 3 BK	28697.4	10	3 mm
	KDS-DE 3-4 BK	28523.4	10	4 mm
	KDS-DE 4-5 BK	28524.4	10	5 mm
	KDS-DE 5-6 BK	28525.4	10	6 mm
	KDS-DE 6-7 BK	28526.4	10	7 mm
	KDS-DE 7-8 BK	28527.4	10	8 mm
	KDS-DE 8-9 BK	28528.4	10	9 mm
	KDS-DE 9-10 BK	28529.4	10	10 mm
	KDS-DE 10-11 BK	28530.4	10	11 mm
	KDS-DE 11-12 BK	28531.4	10	12 mm
	KDS-DE 12-13 BK	28532.4	10	13 mm
KDS-DE 13-14 BK	28533.4	10	14 mm	
KDS-DE 14-15 BK	28608.4	10	15 mm	
KDS-DE 15-16 BK	28670.4	10	16 mm	

Seals	Black large			
	KDS-DEG/B BK	28534.4	10	Blind
	KDS-DEG 14-15 BK	28535.4	10	15 mm
	KDS-DEG 15-16 BK	28536.4	10	16 mm
	KDS-DEG 16-17 BK	28537.4	10	17 mm
	KDS-DEG 17-18 BK	28538.4	10	18 mm
	KDS-DEG 18-19 BK	28539.4	10	19 mm
	KDS-DEG 19-20 BK	28540.4	10	20 mm
	KDS-DEG 20-21 BK	28541.4	10	21 mm
	KDS-DEG 21-22 BK	28542.4	10	22 mm
	KDS-DEG 22-23 BK	28543.4	10	23 mm
	KDS-DEG 23-24 BK	28544.4	10	24 mm
	KDS-DEG 24-25 BK	28545.4	10	25 mm
	KDS-DEG 25-26 BK	28546.4	10	26 mm
	KDS-DEG 26-27 BK	28547.4	10	27 mm
	KDS-DEG 27-28 BK	28548.4	10	28 mm
	KDS-DEG 28-29 BK	28549.4	10	29 mm
	KDS-DEG 29-30 BK	28550.4	10	30 mm
KDS-DEG 30-31 BK	28551.4	10	31 mm	
KDS-DEG 31-32 BK	28552.4	10	32 mm	
KDS-DEG 32-33 BK	28601.4	10	33 mm	
KDS-DEG 33-34 BK	28730.4	10	34 mm	
KDS-DEG 34-35 BK	28732.4	10	35 mm	

Seals with multiple holes	Black multiple			
	KDS-DE 2x4-5 BK	28555.4	10	5 mm
	KDS-DE 2x5-6 BK	28556.4	10	6 mm
	KDS-DE 2x6.5 BK	28682.4	10	6.5 mm
	KDS-DE 2x7 BK	28689.4	10	7 mm
	KDS-DE 2x8 BK	28691.4	10	8 mm
	KDS-DE 3x5-6 BK	28687.4	10	6 mm
	KDS-DE 4x2-3 BK	28557.4	10	3 mm
	KDS-DE 4x3-4 BK	28558.4	10	4 mm
	KDS-DE 4x4.5 BK	28681.4	10	4.5 mm
	KDS-DE 4x5 BK	28672.4	10	5 mm
	KDS-DE 4x6 BK	28763.4	10	6 mm

Seals for AS interface cables	Black			
	KDS-DE/1xASI BK	28559.4	10	
	KDS-DE/2xASI BK	28560.4	10	

Cone-shaped seals	Black			
	KDS-DE/K 2-11 BK	28553.4	10	11 mm
	KDS-DEG/K 7-24 BK	28554.4	10	24 mm

	IP66	UL TYPE Rating 12	UL TYPE* Rating 4x
	RoHS compliant	Made in Germany	
			DNV-GL Approved Products

* 4x is for indoor use only



Features

- Material: TPE
- Flammability: UL 94 HB
- Temperature range: -40 °C to +120 °C (static)
- Halogen-free, silicone-free
- High chemical resistance
- UV-stabilized
- Protection: IP66

KDS-DES seals

The **KDS-DES** seals enable you to install non-assembled cables. The corresponding membrane must be pierced (center point is marked) to insert the cables. The cables can then be guided through the seal. Thanks to their design based on the proven **KES system**, the **KDS-DES** seals ensure an IP54-tight seal. Despite the high-density assembly (up to eight cables), the **KDS-DES** seals are compatible with almost all **KDS** solutions (refer to the overview on pages 60 – 61).

The seals' conical shape enables them to be easily pressed in so they can seal gaps. For the assembly, they are pressed into the selected **KDS** system from the inside outwards.



Features

- Material: TPE
- Flammability: UL 94 V-0
- Temperature range: -40 °C to +90 °C (static)
- Halogen-free, silicone-free
- Protection class: IP54

Seals	KDS-DES 2X10.5	KDS-DES 3X9.5	KDS-DES 3X8.5	KDS-DES 4X7.5
Diagram				
Type	KDS-DES 2X10.5 GR ●	KDS-DES 3X9.5 GR ●	KDS-DES 3X8.5 GR ●	KDS-DES 4X7.5 GR ●
Cat. no.	28800.6	28801.6	28802.6	28803.6
Qty.	5	5	5	5
Size (L x W x H), mm	42.69 x 21.1 x 17.7	42.69 x 21.1 x 17.7	42.69 x 21.1 x 17.7	42.69 x 21.1 x 17.7
Connection data				
Number of cables x cable diameter (mm)	2 x 10.5	3 x 9.5	3 x 8.5	4 x 7.5

Seals	KDS-DES 7X6.5	KDS-DES 8X5.5	KDS-DES 8X4.5	
Diagram				
Type	KDS-DES 7X6.5 GR ●	KDS-DES 8X5.5 GR ●	KDS-DES 8X4.5 GR ●	
Cat. no.	28804.6	28805.6	28806.6	
Qty.	5	5	5	
Size (L x W x H), mm	42.69 x 21.1 x 17.7	42.69 x 21.1 x 17.7	42.69 x 21.1 x 17.7	
Connection data				
Number of cables x cable diameter (mm)	7 x 6.5	8 x 5.5	8 x 4.5	

The KDS-DES is compatible with the following frames:

Type	Cat. no.
KDS-SR-FB1/A BK	28700.4
KDS-SR-FB2/B BK	28702.4
KDS-SR-FB3/C BK	28705.4
KDS-SR-FB3/D BK	28706.4
KDS-SR-FB4/B BK	28708.4
KDS-SR-FB4/E BK	28711.4
KDS-SR 1-4 BK*	28506.4
KDS-SR 6/10 BK*	28500.4
KDS-SR 8/16 BK*	28502.4
KDS-SR 10/24 BK*	28504.4
KDS-FP 2x10/24 BK*	28660.4
KDS-FP 3x10/24 BK*	28661.4
KDS-KV M40 BK	28613.4
KDS-KV M50 BK	28614.4
KDS-KV M63 BK	28615.4
KDS-R 40-63 BK**	28774.4

* Combined with the KDS-Inlay 1 or KDS-Inlay 2

** Only in combination with KDS-RGA M63

IP54

RoHS compliant

Made in Germany



Combination options for the modular KDSClick system

KDSI-SR frames ●



4-piece frame
KDSI-SR 1-4 BK
28880.4



6-piece frame
KDSI-SR 6/10 BK
28881.4



8-piece frame
KDSI-SR 8/16 BK
28882.4



10-piece frame
KDSI-SR 10/24 BK
28883.4

KDS-SR frames ●



4-piece frame
KDS-SR 1-4 BK
28506.4



6-piece frame
KDS-SR 6/10 BK
28500.4



8-piece frame
KDS-SR 8/16 BK
28502.4



10-piece frame
KDS-SR 10/24 BK
28504.4

Many combinations for your individual requirements

4-piece frame KDSI-SR 1-4 or KDS-SR 1-4			
1-piece inlay	2-piece inlay	4-piece inlay	

6-piece frame KDSI-SR 6/10 or KDS-SR 6/10			
1-piece inlay	2-piece inlay	4-piece inlay	6-piece inlay

Inlays



KDS-Inlay 1 BK
28516.4



KDS-Inlay 2 BK
28517.4



KDS-Inlay 2 BK
28517.4



KDS-Inlay 4 BK
28518.4



KDS-Inlay 6 BK
28519.4

8-piece frame KDS-SR 8/16 or KDSI-SR 8/16



10-piece frame KDS-SR 10/24 or KDSI-SR 10/24



KES

Cable entries

When feeding in non-assembled cables, lines and pneumatic hoses (without connected plugs), CONTA-CLIP has a wide range of products that offer alternatives to cable glands or single-membrane feed-throughs.

The **KES** cable entries are very flat; they enable space-saving professional cable entries with a very tight seal.

Due to its high assembly density, the **KES** system is well suited for applications where the installations must be carried out in confined spaces.



Your advantages

- Can be screwed/snapped on
- Very high stability (core: PA 6.6 GF)
- Outstanding strain relief (cone grommet)
- Very simple assembly
(with marked centring point)
- High-density assemblies
- double seal/tightness: IP66
- Hygienic design: no dirt-prone niches
- Large assortment (48 varieties)
- UL-listed plastic materials
- UL 94 V-0

Two components

The **KES** system consists of two components. The inner core, made of polyamide PA 6.6 GF, is crucial for the stability and strain relief; it is over-moulded in the sealing areas with TPE to ensure an IP66 protective seal.



Many cables in a confined space

Many cables (with various diameters from 3.2 to 20.5 mm) can be inserted in a confined space and double sealed (IP66) thanks to the special construction of the conical grommets. There are three ways that the **KES** system can be installed: screw fastening from outside, screw fastening with threaded bushes and locking hooks from the inside, or snap-in fastening from the outside.

The corresponding membrane must be pierced (center point is marked) to insert the cables.



UL 94 V-0 classification

The **KES** is designed for use in mounting cut-outs of 24-pin heavy-duty connectors. All variants are available in grey and black. The materials used comply with the UL 94 V-0 classification.



	IP66	UL TYPE Rating 12	UL TYPE* Rating 4x
ECOLAB certified	RoHS compliant	Made in Germany	

* 4x is for indoor use only

KES Cable entries

An overview of your advantages

High-density assemblies

In contrast to the classic cable gland, the **KES** allows many cables, hoses and lines to be installed in a space-saving manner, even in cramped installation conditions.



Very precise

The piercing points are clearly marked so that cables and hoses can be centred precisely.

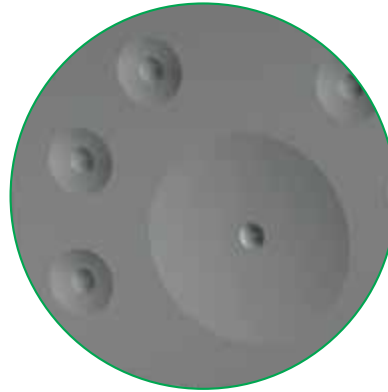

Integrated strain relief

The special shape of the multi-layered membrane cone grommet ensures an optimal strain relief mechanism for the cables, in accordance with DIN EN 62444.

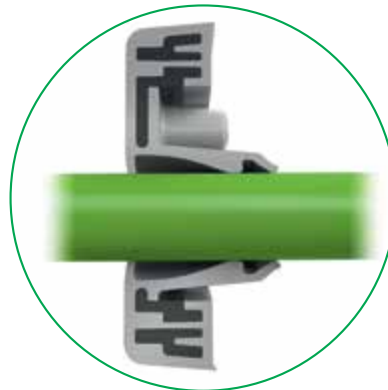

Can be used from -40 °C to +90 °C

Materials contain no halogen or silicone; suitable for many different applications.

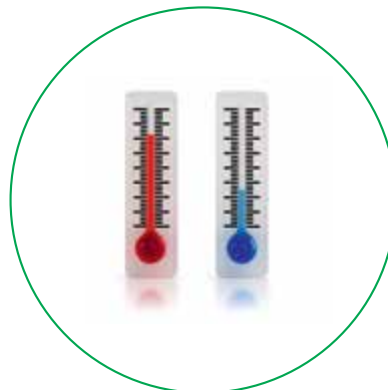

* 4x is for indoor use only

You can choose one of three attachment options to fit your requirements.

1. Screw-on mount



The **KES** (without threaded bush) is screwed from the outside onto the housing wall.

2. Screw-on mount with threaded bushes and latching clips



Using the latching clips, the **KES-GB** latches onto the outside of the housing wall. It is then screwed on from the inside, through the housing wall, using the integrated threaded bushes.

3. Latched (snap-on) mount using latching hooks



The **KES-R** is latched from outside to the housing wall using the latching clips.

KES Cable entries

Cable entries		KES 13/24	KES 14/24	KES 16/24
				
Diagram		Page 60	Page 60	Page 60
Mounting type Screw-on mount				
				
Type / colour		KES 13/24 GR ●	KES 14/24 GR ●	KES 16/24 GR ●
<i>Cat. no.</i>	Qty.	28630.6 10	28631.6 10	28632.6 10
Type / colour		KES 13/24 BK ●	KES 14/24 BK ●	KES 16/24 BK ●
<i>Cat. no.</i>	Qty.	28630.4 10	28631.4 10	28632.4 10
Mounting type Screw fastening with pressed-in threaded bush and snap-in latching clips.				
				
Type / colour		KES-GB 13/24 GR ●	KES-GB 14/24 GR ●	KES-GB 16/24 GR ●
<i>Cat. no.</i>	Qty.	28640.6 10	28641.6 10	28642.6 10
Type / colour		KES-GB 13/24 BK ●	KES-GB 14/24 BK ●	KES-GB 16/24 BK ●
<i>Cat. no.</i>	Qty.	28640.4 10	28641.4 10	28642.4 10
Mounting type Tool-free latch-on mount				
				
Type / colour		KES-R 13/24 GR ●	KES-R 14/24 GR ●	KES-R 16/24 GR ●
<i>Cat. no.</i>	Qty.	28650.6 10	28651.6 10	28652.6 10
Type / colour		KES-R 13/24 BK ●	KES-R 14/24 BK ●	KES-R 16/24 BK ●
<i>Cat. no.</i>	Qty.	28650.4 10	28651.4 10	28652.4 10
Connection data				
Number of cables x cable diameter (mm)		10 x 3.2 – 6.3 3 x 16 – 20.5	5 x 3.2 – 6.3 2 x 4 – 7.5 3 x 5.5 – 10.5 1 x 8 – 12.5 3 x 12 – 16.2	8 x 3.2 – 5.5 6 x 5 – 8.5 2 x 9.5 – 14.5
Features				
Material of frame / sealing plate		PA 6.6 GF / elastomer	PA 6.6 GF / elastomer	PA 6.6 GF / elastomer
Temperature range		-40 °C to +90 °C	-40 °C to +90 °C	-40 °C to +90 °C
Protection		IP66 (with snap-in mount: IP54)	IP66 (with snap-in mount: IP54)	IP66 (with snap-in mount: IP54)
Flammability class		UL 94 V-0	UL 94 V-0	UL 94 V-0
Accessories				
Sheet-metal hole punch (refer to page 92)		BL KES	BL KES	BL KES
<i>Cat. no.</i>	Qty.	28744.0 1	28744.0 1	28744.0 1

	IP66	UL TYPE Rating 12	UL TYPE* Rating 4x
ECOLAB certified	RoHS compliant	Made in Germany	

* 4x is for indoor use only

KES 16-1/24		KES 17/24		KES 20/24		KES 21/24		KES 32/24	
									
Page 60		Page 61		Page 61		Page 61		Page 61	
KES 16-1/24 GR ●		KES 17/24 GR ●		KES 20/24 GR ●		KES 21/24 GR ●		KES 32/24 GR ●	
28633.6	10	28634.6	10	28635.6	10	28636.6	10	28637.6	10
KES 16-1/24 BK ●		KES 17/24 BK ●		KES 20/24 BK ●		KES 21/24 BK ●		KES 32/24 BK ●	
28633.4	10	28634.4	10	28635.4	10	28636.4	10	28637.4	10
KES-GB 16-1/24 GR ●		KES-GB 17/24 GR ●		KES-GB 20/24 GR ●		KES-GB 21/24 GR ●		KES-GB 32/24 GR ●	
28643.6	10	28644.6	10	28645.6	10	28646.6	10	28647.6	10
KES-GB 16-1/24 BK ●		KES-GB 17/24 BK ●		KES-GB 20/24 BK ●		KES-GB 21/24 BK ●		KES-GB 32/24 BK ●	
28643.4	10	28644.4	10	28645.4	10	28646.4	10	28647.4	10
KES-R 16-1/24 GR ●		KES-R 17/24 GR ●		KES-R 20/24 GR ●		KES-R 21/24 GR ●		KES-R 32/24 GR ●	
28653.6	10	28654.6	10	28655.6	10	28656.6	10	28657.6	10
KES-R 16-1/24 BK ●		KES-R 17/24 BK ●		KES-R 20/24 BK ●		KES-R 21/24 BK ●		KES-R 32/24 BK ●	
28653.4	10	28654.4	10	28655.4	10	28656.4	10	28657.4	10
2 x 3.2 – 6.3		4 x 3.2 – 6.3		12 x 3.2 – 6.3		1 x 3.2 – 6.3		32 x 3.2 – 6.3	
9 x 4 – 7.5		2 x 4 – 7.5		8 x 5.5 – 10.5		14 x 4 – 7.5			
1 x 5.5 – 10.5		1 x 5.5 – 10.5				4 x 5.5 – 10.5			
1 x 8 – 12.5		10 x 8 – 12.5				2 x 8 – 12.5			
3 x 12 – 16.2									
PA 6.6 GF / elastomer		PA 6.6 GF / elastomer		PA 6.6 GF / elastomer		PA 6.6 GF / elastomer		PA 6.6 GF / elastomer	
-40 °C to +90 °C		-40 °C to +90 °C		-40 °C to +90 °C		-40 °C to +90 °C		-40 °C to +90 °C	
IP66 (with snap-in mount: IP54)		IP66 (with snap-in mount: IP54)		IP66 (with snap-in mount: IP54)		IP66 (with snap-in mount: IP54)		IP66 (with snap-in mount: IP54)	
UL 94 V-0		UL 94 V-0		UL 94 V-0		UL 94 V-0		UL 94 V-0	
BL KES		BL KES		BL KES		BL KES		BL KES	
28744.0	1	28744.0	1	28744.0	1	28744.0	1	28744.0	1

KES

Dimensional diagrams / Mounting cut-out for cable entries

KES 13/24

Dimensional diagram

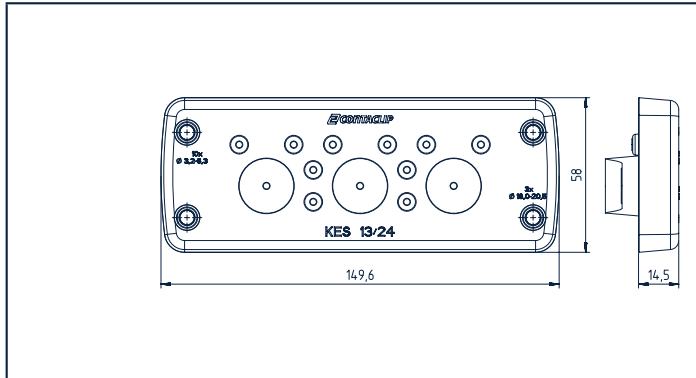

Mounting cut-out

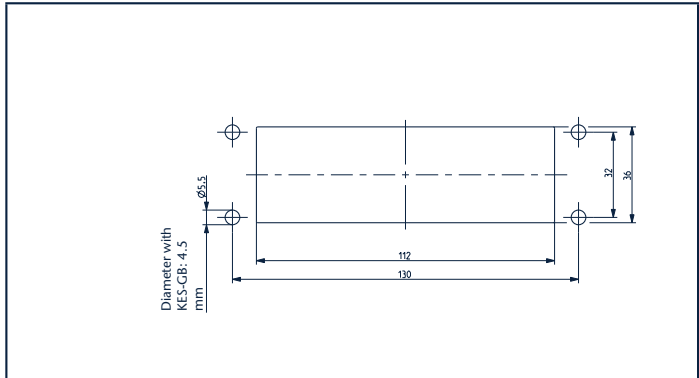

Torque for the frame's mounting screw: 2.5 – 3 Nm

KES 14/24

Dimensional diagram

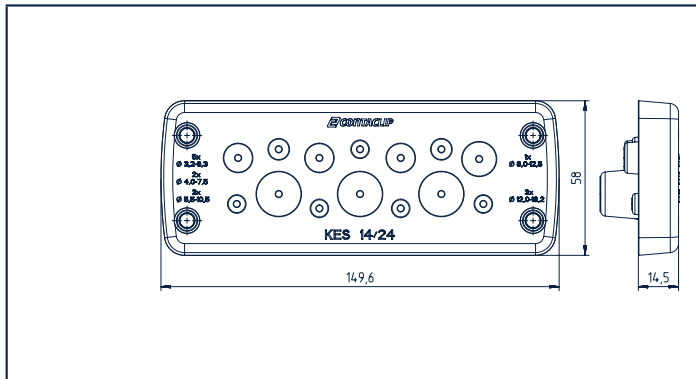

Mounting cut-out

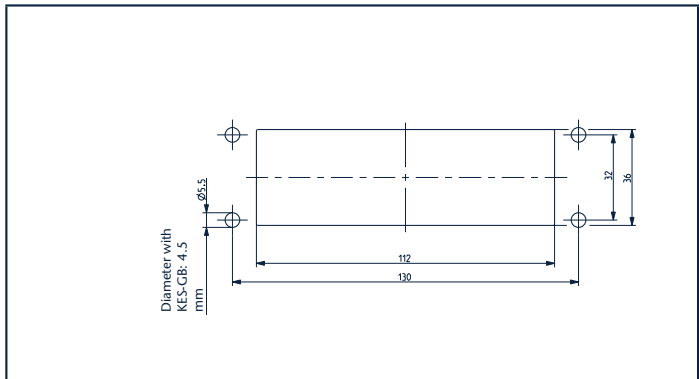

Torque for the frame's mounting screw: 2.5 – 3 Nm

KES 16/24

Dimensional diagram

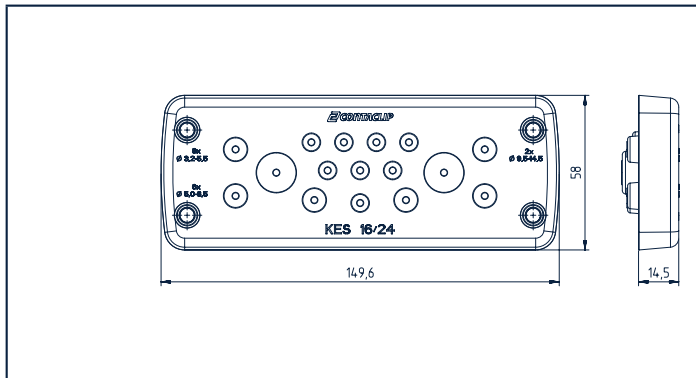

Mounting cut-out

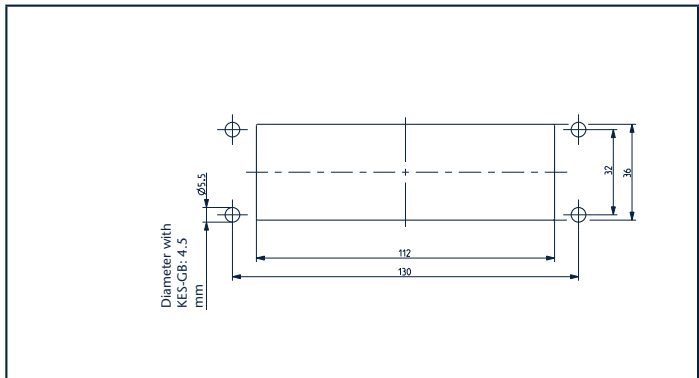

Torque for the frame's mounting screw: 2.5 – 3 Nm

KES 16-1/24

Dimensional diagram

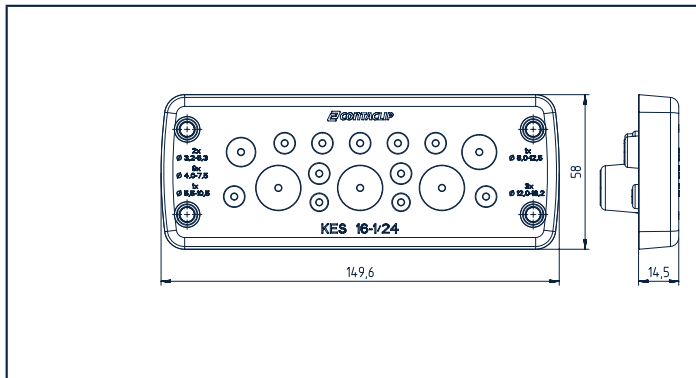

Mounting cut-out

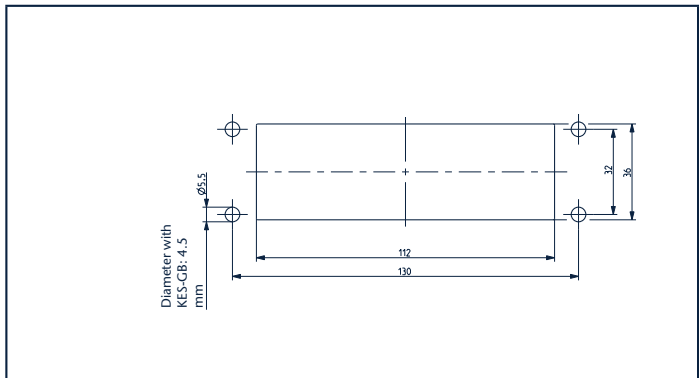

Torque for the frame's mounting screw: 2.5 – 3 Nm

KES 17/24

Dimensional diagram

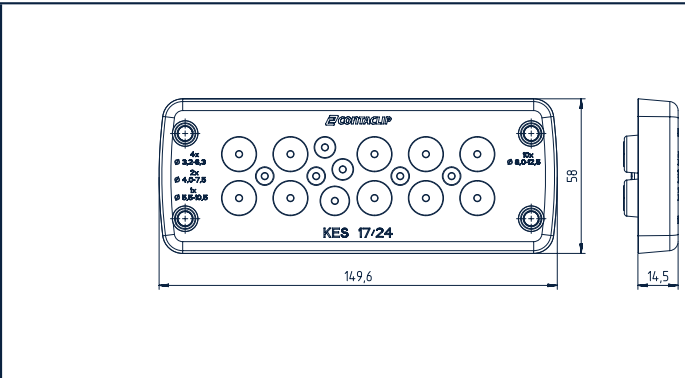

Mounting cut-out

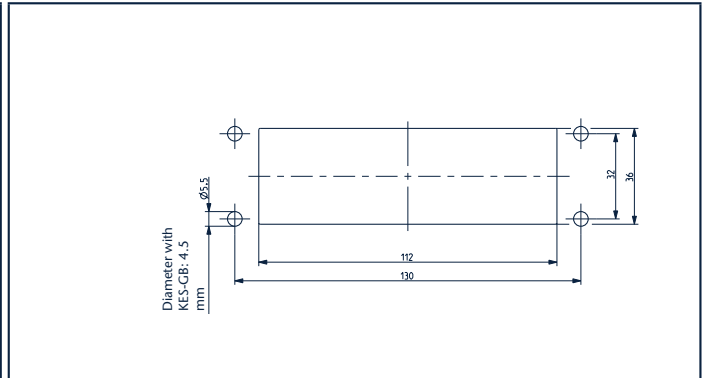

Torque for the frame's mounting screw: 2.5 – 3 Nm

KES 20/24

Dimensional diagram

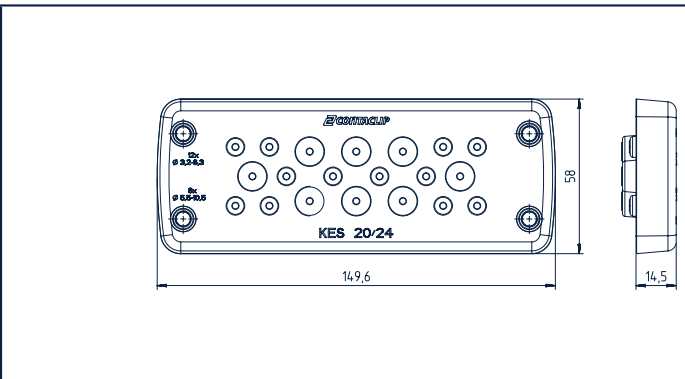

Mounting cut-out

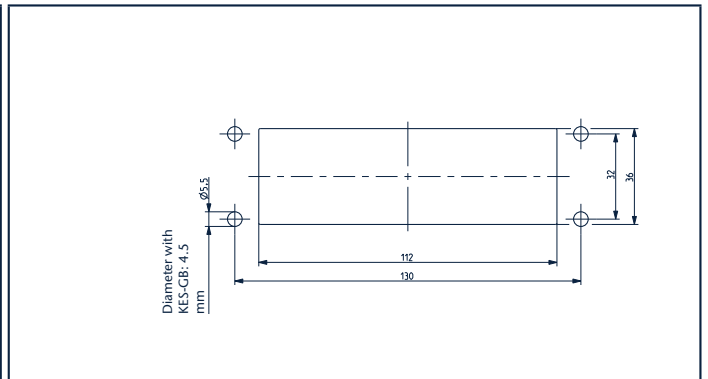

Torque for the frame's mounting screw: 2.5 – 3 Nm

KES 21/24

Dimensional diagram

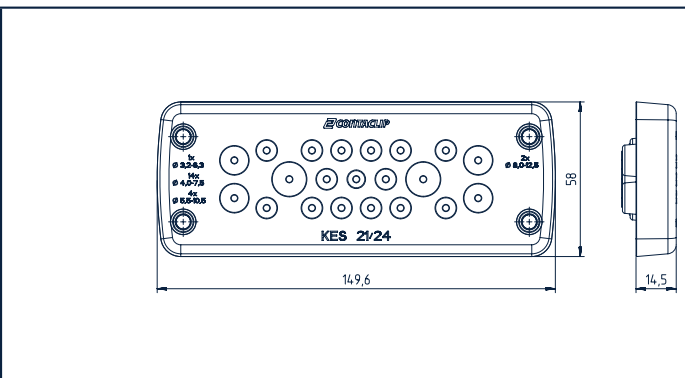

Mounting cut-out

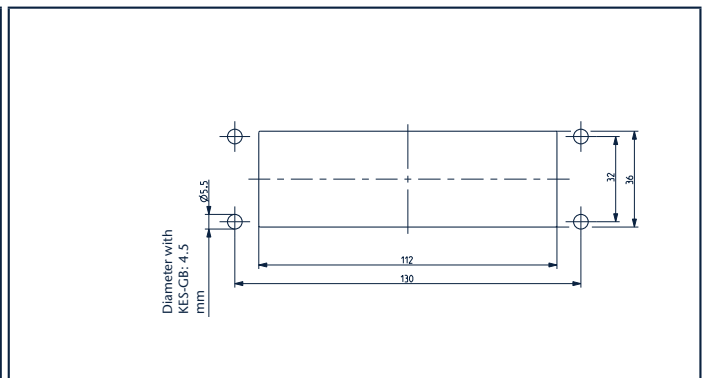

Torque for the frame's mounting screw: 2.5 – 3 Nm

KES 32/24

Dimensional diagram

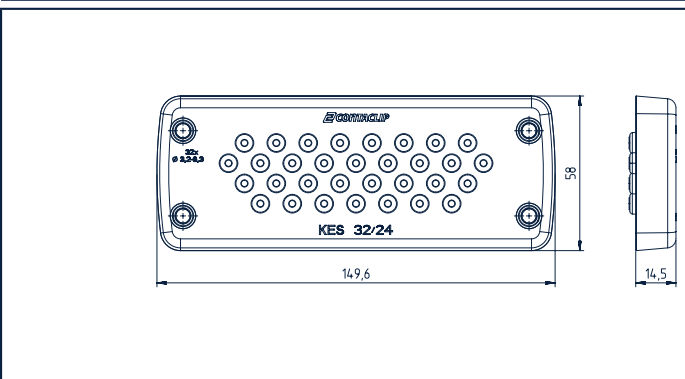

Mounting cut-out

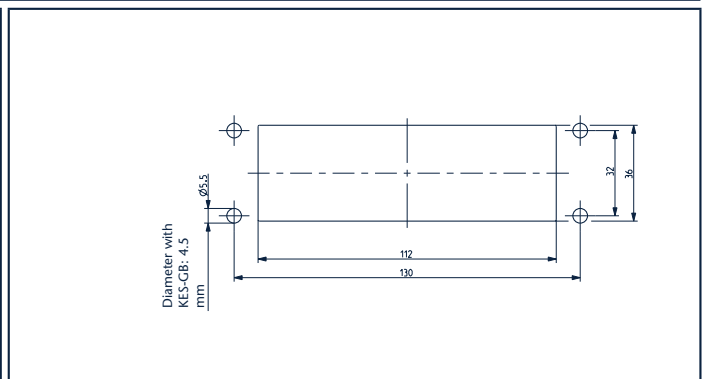

Torque for the frame's mounting screw: 2.5 – 3 Nm

KES-E Cable entries

Many cables in a confined space: The **KES-E** cable entry system enables you to insert many cables (without plugs) with diameters ranging from 1.0 mm to 16.1 mm into a very confined space. The cable entry is inserted without tools into the intended opening (variant "A" for wall thickness from 1.5 to 2.5 mm, and variant "B" for wall thickness from 2.5 to 4.0 mm).

In order to insert the cables, the corresponding membrane (with marked centring point) must be pierced; the cables are then simply guided through. The material TPE guarantees that IP54 protection is maintained.



Your advantages

- Tool-free installation
- Outstanding stability
- Simple assembly (with marked centre point)
- High-density assemblies
- Hygienic design
- For walls of various thickness



Features

- Material: TPE
- Flammability: UL 94 V-0
- Temperature range: -40 °C to +90 °C (static)
- Halogen-free, silicone-free
- Wall thickness A: 1.5 – 2.5 mm, and B: 2.5 – 4.0 mm
- Protection class: IP54

KES-E variety



KES-E 12/24



KES-E 14/24



KES-E 17/24



KES-E 18/24



KES-E 19/24



KES-E 26/24



KES-E 42/24



KES-E 48/24



KES-E 50/24



UL TYPE
Rating
12



IP54



RoHS
compliant



Made in
Germany



KES-E Cable entries

Cable entries		KES-E 12/24	KES-E 14/24	KES-E 17/24
				
Type		KES-E 12/24 A GR ●	KES-E 14/24 A GR ●	KES-E 17/24 A GR ●
<i>Cat. no.</i>	Qty.	28810.6 10	28811.6 10	28812.6 10
For wall thickness		1.5–2.5	1.5–2.5	1.5–2.5
Type		KES-E 12/24 B GR ●	KES-E 14/24 B GR ●	KES-E 17/24 B GR ●
<i>Cat. no.</i>	Qty.	28840.6 10	28841.6 10	28842.6 10
For wall thickness		2.5–4.0	2.5–4.0	2.5–4.0
Connection data				
Number of cables x cable diameter (mm)		12 x 1.0–15.0	14 x 1.0–12.1	5 x 1.0–10.5 12 x 1.0–12.6
Features				
Protection		IP54	IP54	IP54

Cable entries		KES-E 18/24	KES-E 19/24	KES-E 26/24
				
Type		KES-E 18/24 A GR ●	KES-E 19/24 A GR ●	KES-E 26/24 A GR ●
<i>Cat. no.</i>	Qty.	28813.6 10	28814.6 10	28815.6 10
For wall thickness		1.5–2.5	1.5–2.5	1.5–2.5
Type		KES-E 18/24 B GR ●	KES-E 19/24 B GR ●	KES-E 26/24 B GR ●
<i>Cat. no.</i>	Qty.	28843.6 10	28844.6 10	28845.6 10
For wall thickness		2.5–4.0	2.5–4.0	2.5–4.0
Connection data				
Number of cables x cable diameter (mm)		4 x 1.0–6.5 5 x 1.0–10.5 5 x 1.0–12.5 4 x 1.0–16.1	12 x 1.0–6.5 7 x 1.0–12.1	16 x 1.0–6.5 4 x 1.0–12.1 4 x 1.0–16.1 2 x ASI
Features				
Protection		IP54	IP54	IP54

Cable entries		KES-E 42/24	KES-E 48/24	KES-E 50/24
				
Type		KES-E 42/24 A GR ●	KES-E 48/24 A GR ●	KES-E 50/24 A GR ●
<i>Cat. no.</i>	Qty.	28816.6 10	28817.6 10	28818.6 10
For wall thickness		1.5–2.5	1.5–2.5	1.5–2.5
Type		KES-E 42/24 B GR ●	KES-E 48/24 B GR ●	KES-E 50/24 B GR ●
<i>Cat. no.</i>	Qty.	28846.6 10	28847.6 10	28848.6 10
For wall thickness		2.5–4.0	2.5–4.0	2.5–4.0
Connection data				
Number of cables x cable diameter (mm)		12 x 1.0–7.2 17 x 1.0–6.4 12 x 1.0–5.0 1 x 1.0–4.7	48 x 1.0–6.5	33 x 1.0–5.3 9 x 1.0–6.4 8 x 1.0–8.3
Features				
Protection		IP54	IP54	IP54

KES-E

Dimensional diagrams / Mounting cut-out for cable entries

KES-E 12/24

Dimensional diagram

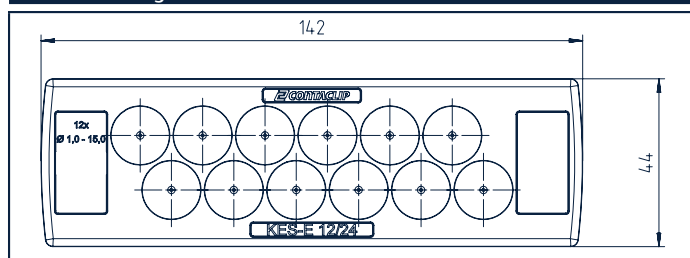

KES-E 14/24

Dimensional diagram

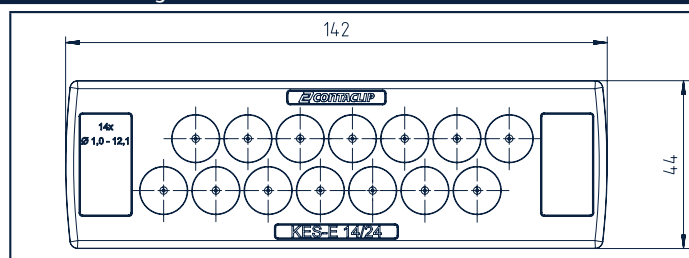

KES-E 17/24

Dimensional diagram

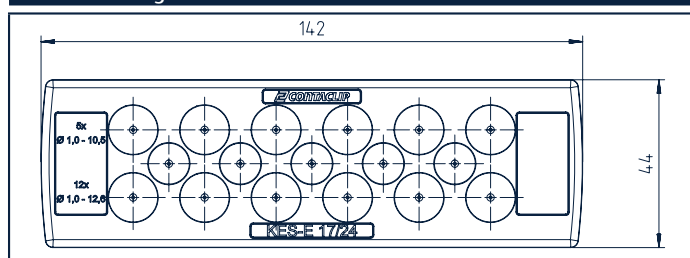

KES-E 18/24

Dimensional diagram

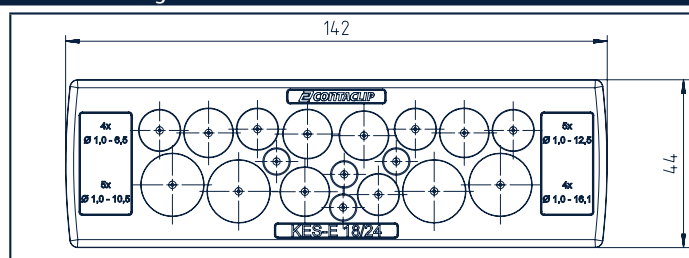

KES-E 19/24

Dimensional diagram

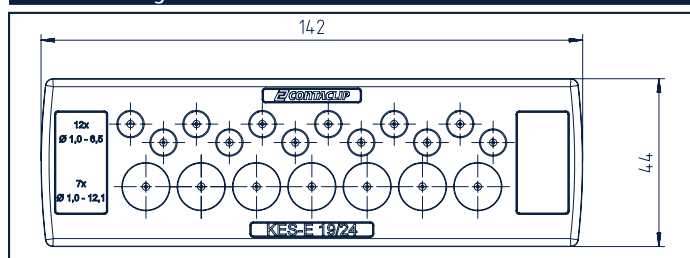

KES-E 26/24

Dimensional diagram

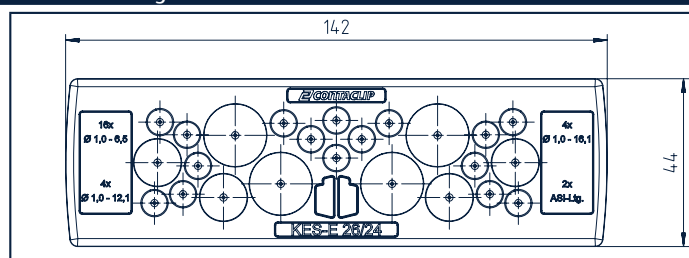

KES-E 42/24

Dimensional diagram

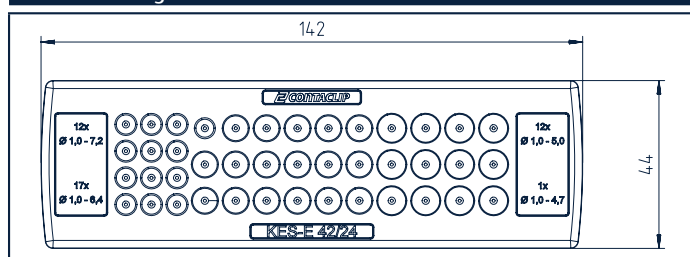

KES-E 48/24

Dimensional diagram

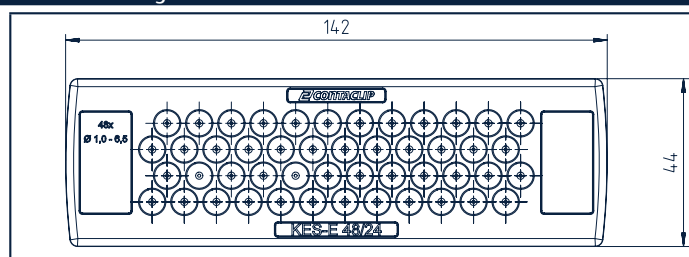

KES-E 50/24

Dimensional diagram

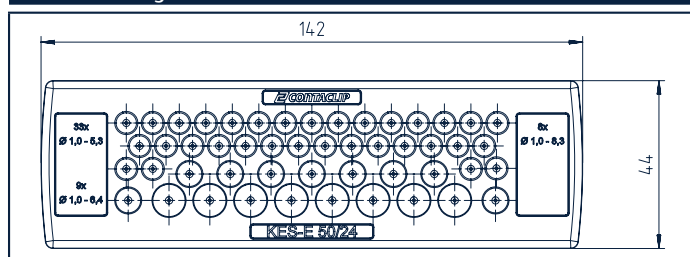

Mounting cut-out

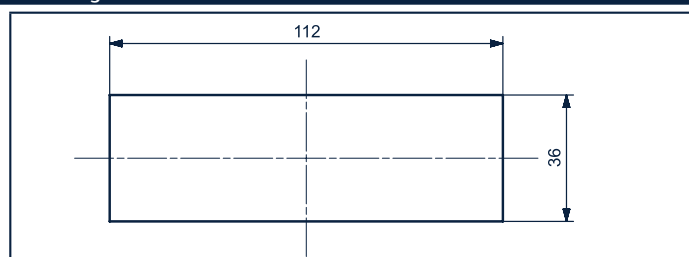

UL TYPE
Rating
12

IP54

RoHS
compliant

Made in
Germany



KES-E-R

Round cable entries

Many cables in a confined space: The **KES-E-R** cable entry system enables you to insert many cables (without plugs) with diameters ranging from 1.0 mm to 22.5 mm into a very confined space. The cable entry is inserted without tools into the intended opening (variant "A" for wall thickness from 1.5 to 2.5 mm, and variant "B" for wall thickness from 2.5 to 4.0 mm).

In order to insert the cables, the corresponding membrane (with marked centring point) must be pierced; the cables are then simply guided through. The material TPE guarantees that IP54 protection is maintained.

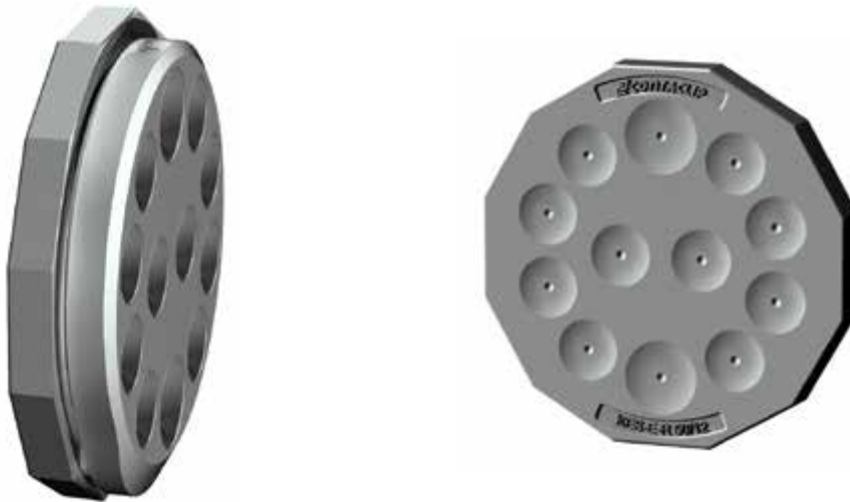

Your advantages

- Tool-free installation
- Outstanding stability
- Simple assembly (with marked centre point)
- High-density assemblies
- Hygienic design
- For walls of various thickness



Features

- Material: TPE
- Flammability: UL 94 V-0
- Temperature range: -40 °C to +90 °C (static)
- Halogen-free, silicone-free
- Wall thickness A: 1.5 – 2.5 mm, and B: 2.5 – 4.0 mm
- Protection class: IP54

KES-E-R variety



KES-E-R 50/9



KES-E-R 50/11



KES-E-R 50/12



KES-E-R 50/16



KES-E-R 50/18



KES-E-R 50/20



KES-E-R 50/35



UL TYPE
Rating
12

UL TYPE*
Rating
4x

IP54

RoHS
compliant



Made in
Germany





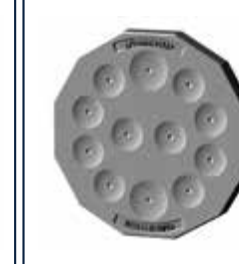

* 4x is for indoor use only

KES-E-R

Round cable entries

Round cable entries		KES-E-R 50/9	KES-E-R 50/11	KES-E-R 50/12
				
Type		KES-E-R 50/9 A GR ●	KES-E-R 50/11 A GR ●	KES-E-R 50/12 A GR ●
<i>Cat. no.</i>	Qty.	28829.6 10	28830.6 10	28831.6 10
For wall thickness		1.5–2.5	1.5–2.5	1.5–2.5
Type		KES-E-R 50/9 B GR ●	KES-E-R 50/11 B GR ●	KES-E-R 50/12 B GR ●
<i>Cat. no.</i>	Qty.	28859.6 10	28860.6 10	28861.6 10
For wall thickness		2.5–4.0	2.5–4.0	2.5–4.0
Connection data				
Number of cables x cable diameter (mm)		5 x 1.0–7.0 4 x 1.0–18.0	7 x 1.0–7.2 3 x 1.0–11.2 1 x 1.0–22.5	10 x 1.0–9.2 2 x 1.0–11.2
Features				
Protection		IP54	IP54	IP54

Round cable entries		KES-E-R 50/16	KES-E-R 50/18	KES-E-R 50/20
				
Type		KES-E-R 50/16 A GR ●	KES-E-R 50/18 A GR ●	KES-E-R 50/20 A GR ●
<i>Cat. no.</i>	Qty.	28832.6 10	28833.6 10	28834.6 10
For wall thickness		1.5–2.5	1.5–2.5	1.5–2.5
Type		KES-E-R 50/16 B GR ●	KES-E-R 50/18 B GR ●	KES-E-R 50/20 B GR ●
<i>Cat. no.</i>	Qty.	28862.6 10	28863.6 10	28864.6 10
For wall thickness		2.5–4.0	2.5–4.0	2.5–4.0
Connection data				
Number of cables x cable diameter (mm)		4 x 1.0–5.3 5 x 1.0–6.3 3 x 1.0–9.5 4 x 1.0–11.3	2 x 1.0–4.0 2 x 1.0–6.0 4 x 1.0–7.2 5 x 1.0–9.4 5 x 1.0–12.0	16 x 1.0–6.3 4 x 1.0–9.3
Features				
Protection		IP54	IP54	IP54

Round cable entries		KES-E-R 50/35		
				
Type		KES-E-R 50/35 A GR ●		
<i>Cat. no.</i>	Qty.	28835.6 10		
For wall thickness		1.5–2.5		
Type		KES-E-R 50/35 B GR ●		
<i>Cat. no.</i>	Qty.	28865.6 10		
For wall thickness		2.5–4.0		
Connection data				
Number of cables x cable diameter (mm)		35 x 1.0–5.2		
Features				
Protection		IP54		

KES-E-R

Dimensional diagrams / Mounting cut-out for cable entries

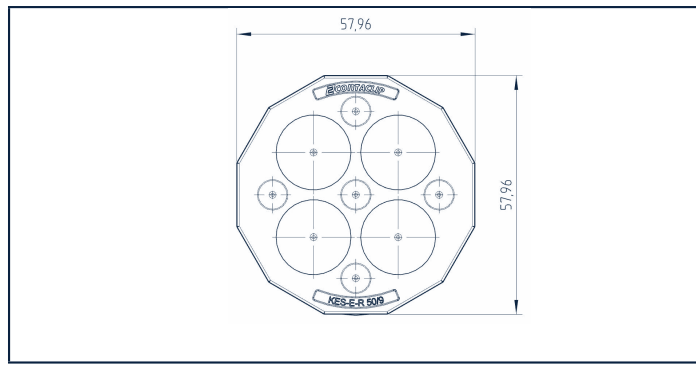
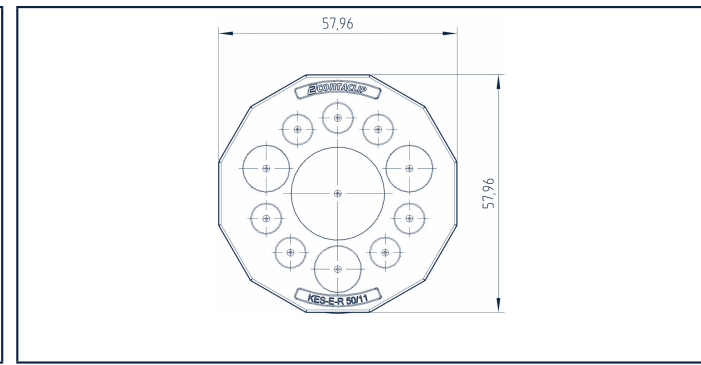
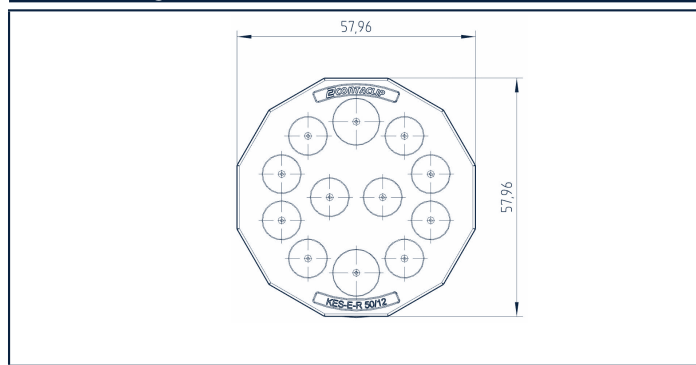
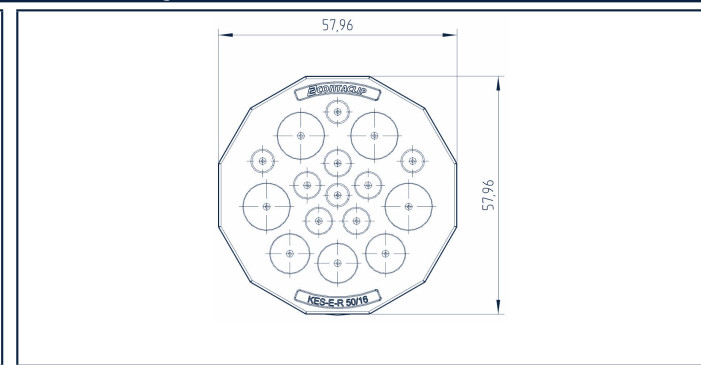
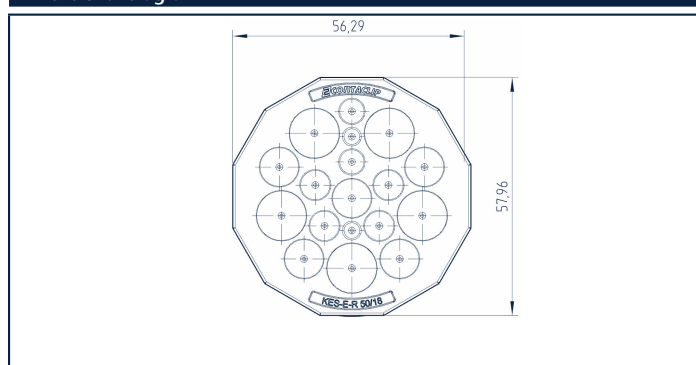
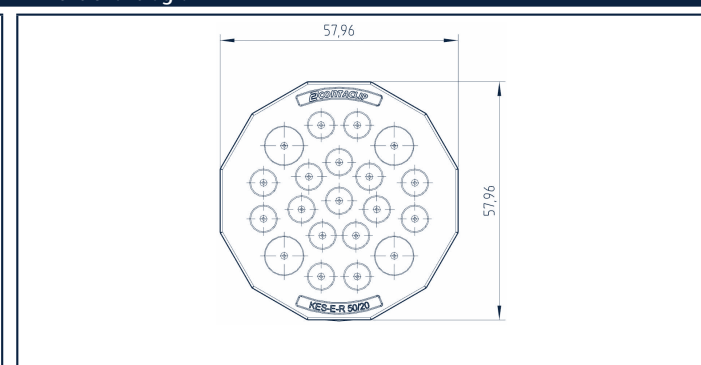
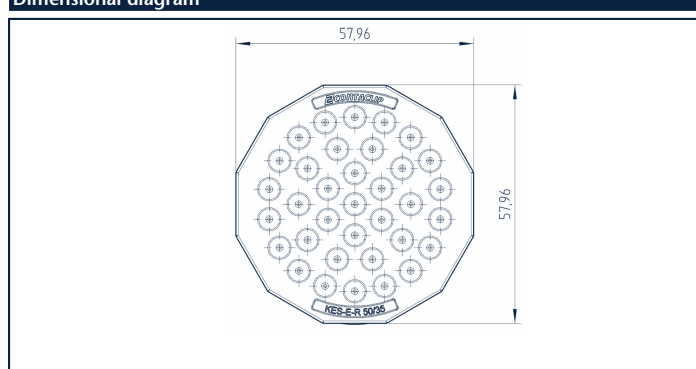
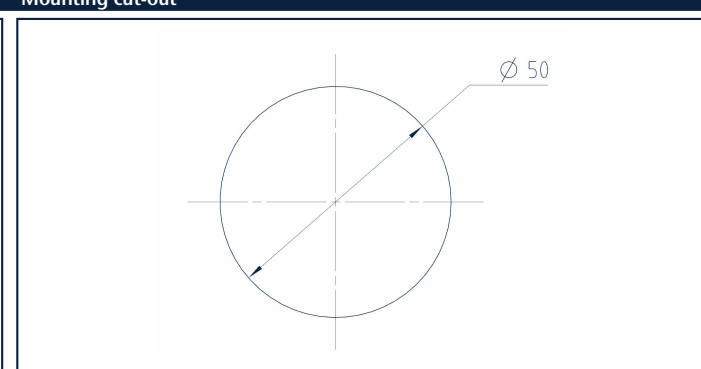
<p>KES-E-R 50/9 Dimensional diagram</p>	<p>KES-E-R 50/11 Dimensional diagram</p>
	
<p>KES-E-R 50/12 Dimensional diagram</p>	<p>KES-E-R 50/16 Dimensional diagram</p>
	
<p>KES-E-R 50/18 Dimensional diagram</p>	<p>KES-E-R 50/20 Dimensional diagram</p>
	
<p>KES-E-R 50/35 Dimensional diagram</p>	<p>Mounting cut-out</p>
	

	<p>UL TYPE Rating 12</p>	<p>UL TYPE* Rating 4x</p>	<p>IP54</p>	<p>RoHS compliant</p>	<p>Made in Germany</p>	
---	---	--	--------------------	----------------------------------	----------------------------	---

* 4x is for indoor use only

KES-GB-FDA

Cable entries for food industry applications

In the food industry, there are strict hygiene regulations which require that all surfaces in the immediate vicinity of the process can be cleaned easily, thoroughly and without abrasion.

Of course, these cover the cable entries and cable glands that seal the passages of cables and hoses into the interior of machine housings or switchgear. These must not have any rough surfaces, crevices or cracks that could promote germ build-up.

The housing materials and sealing systems must also be able to withstand frequent cleaning processes, even when aggressive chemicals are used.

The cable entry plates from our **KES-GB-FDA** series meet the requirements for use in food production applications. They enable the reliable sealing of up to 32 cables in a very confined space.



Your advantages

- Can be screwed/snapped on
- Very high stability (core: PA 6.6 GF)
- Outstanding strain relief (cone grommet)
- Very simple assembly
(with marked centering point)
- High-density assemblies
- double seal/tightness: IP66
- Hygienic design: no dirt-prone niches
- Large assortment (8 varieties)
- UL-listed plastic materials
- UL 94 HB
- FDA-compliant material

Two components

The **KES-GB-FDA** system consists of two components. The inner core, made of polyamide PA 6.6 GF, is crucial for the stability and strain relief; it is over-moulded in the sealing areas with TPE to ensure an IP66 protective seal.



Many cables in a confined space

Many cables (with various diameters from 3.2 to 20.5 mm) can be inserted in a confined space and double sealed (IP66) thanks to the special construction of the conical grommets. The **KES-GB-FDA** system uses threaded bushes and snap-in hooks from the inside as the attachment mechanism. The corresponding membrane must be pierced (center point is marked) to insert the cables.



FDA-compliant material

The FDA-compliant TPE material meets the requirements of the Food Industry Regulations 1935/2004/EC and (EU) 10/2011, as well as the requirements from the US Food and Drug Administration (FDA). FDA compliant means that a material meets all FDA guidelines determining the safe and direct contact with food.



IP66

RoHS
compliantMade in
Germany

KES-GB-FDA

Cable entries for food industry applications

An overview of your advantages

High-density assemblies

In contrast to the classic cable gland, the **KES** allows many cables, hoses and lines to be installed in a space-saving manner, even in cramped installation conditions.



Very precise

The piercing points are clearly marked so that cables and hoses can be centred precisely.

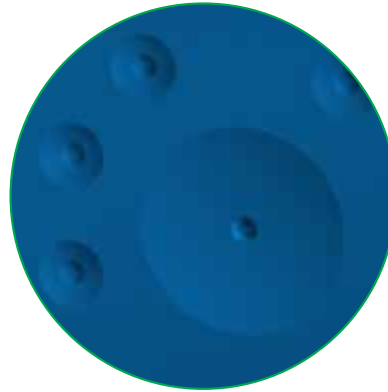

Integrated strain relief

The special shape of the multi-layered membrane cone grommet ensures an optimal strain relief mechanism for the cables, in accordance with DIN EN 62444.

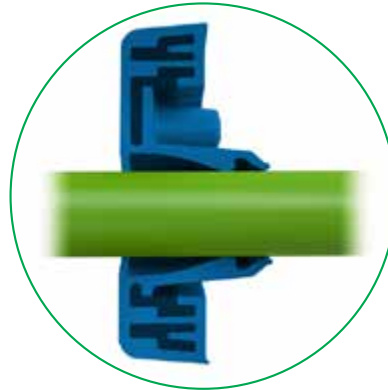

Can be used from

-40 °C to +80 °C

Materials contain no halogen or silicone; suitable for many different applications.

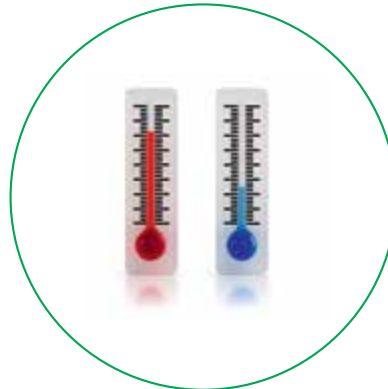

Simple installation

Screw-on mount with threaded bushes and latching clips



Using the latching clips, the **KES-GB-FDA** latches onto the outside of the housing wall. It can then be screwed on from the inside, through the housing wall, using the integrated threaded bushes.

KES-GB-FDA

Cable entries for food industry applications

Cable entries		KES-GB-FDA 13/24	KES-GB-FDA 14/24	KES-GB-FDA 16/24
				
Diagram		Page 84	Page 84	Page 84
Mounting type Screw fastening with pressed-in threaded bush and snap-in latching clips.				
				
Type / colour		KES-GB-FDA 13/24 BU ●	KES-GB-FDA 14/24 BU ●	KES-GB-FDA 16/24 BU ●
<i>Cat. no.</i>	Qty.	28900.5 10	28901.5 10	28902.5 10
Connection data				
Number of cables x cable diameter (mm)		10 x 3.2 – 6.3 3 x 16 – 20.5	5 x 3.2 – 6.3 2 x 4 – 7.5 3 x 5.5 – 10.5 1 x 8 – 12.5 3 x 12 – 16.2	8 x 3.2 – 5.5 6 x 5 – 8.5 2 x 9.5 – 14.5
Features				
Material of frame / sealing plate		PA 6.6 GF / elastomer	PA 6.6 GF / elastomer	PA 6.6 GF / elastomer
Temperature range		-40 °C to +80 °C	-40 °C to +80 °C	-40 °C to +80 °C
Protection		IP66	IP66	IP66
Flammability class		UL 94 HB	UL 94 HB	UL 94 HB
Accessories				
Sheet-metal hole punch (refer to page 92)		BL KES	BL KES	BL KES
<i>Cat. no.</i>	Qty.	28744.0 1	28744.0 1	28744.0 1

IP66

RoHS
compliant

Made in
Germany



KES-GB-FDA 16-1/24	KES-GB-FDA 17/24	KES-GB-FDA 20/24	KES-GB-FDA 21/24	KES-GB-FDA 32/24
				
Page 84	Page 85	Page 85	Page 85	Page 85
KES-GB-FDA 16-1/24 BU ●	KES-GB-FDA 17/24 BU ●	KES-GB-FDA 20/24 BU ●	KES-GB-FDA 21/24 BU ●	KES-GB-FDA 32/24 BU ●
28903.5 10	28904.5 10	28905.5 10	28906.5 10	28907.5 10
2 x 3.2 – 6.3 9 x 4 – 7.5 1 x 5.5 – 10.5 1 x 8 – 12.5 3 x 12 – 16.2	4 x 3.2 – 6.3 2 x 4 – 7.5 1 x 5.5 – 10.5 10 x 8 – 12.5	12 x 3.2 – 6.3 8 x 5.5 – 10.5	1 x 3.2 – 6.3 14 x 4 – 7.5 4 x 5.5 – 10.5 2 x 8 – 12.5	32 x 3.2 – 6.3
PA 6.6 GF / elastomer -40 °C to +80 °C IP66 UL 94 HB	PA 6.6 GF / elastomer -40 °C to +80 °C IP66 UL 94 HB	PA 6.6 GF / elastomer -40 °C to +80 °C IP66 UL 94 HB	PA 6.6 GF / elastomer -40 °C to +80 °C IP66 UL 94 HB	PA 6.6 GF / elastomer -40 °C to +80 °C IP66 UL 94 HB
BL KES	BL KES	BL KES	BL KES	BL KES
28744.0 1	28744.0 1	28744.0 1	28744.0 1	28744.0 1

KES-GB-FDA

Dimensional diagrams / Mounting cut-out for cable entries

KES-GB-FDA 13/24	
Dimensional diagram	Mounting cut-out
<p>KES 13/24 10 x Ø 3.2 – 6.3 mm 3 x Ø 16 – 20.5 mm</p>	<p>Mounting cut-out For wall thickness of 1.5 – 2 mm (for mounting with snap-in hooks)</p>

Torque for the frame's mounting screw: 2.5 – 3 Nm

KES-GB-FDA 14/24	
Dimensional diagram	Mounting cut-out
<p>KES 14/24 5 x Ø 3.2 – 6.3 mm 2 x Ø 4.0 – 7.5 mm 3 x Ø 5.5 – 10.5 mm 1 x Ø 8.0 – 12.5 mm 3 x Ø 12 – 16.2 mm</p>	<p>Mounting cut-out For wall thickness of 1.5 – 2 mm (for mounting with snap-in hooks)</p>

Torque for the frame's mounting screw: 2.5 – 3 Nm

KES-GB-FDA 16/24	
Dimensional diagram	Mounting cut-out
<p>KES 16/24 8 x Ø 3.2 – 5.5 mm 6 x Ø 5.0 – 8.5 mm 2 x Ø 9.5 – 14.5 mm</p>	<p>Mounting cut-out For wall thickness of 1.5 – 2 mm (for mounting with snap-in hooks)</p>

Torque for the frame's mounting screw: 2.5 – 3 Nm

KES-GB-FDA 16-1/24	
Dimensional diagram	Mounting cut-out
<p>KES 16-1/24 2 x Ø 3.2 – 6.3 mm 9 x Ø 4.0 – 7.5 mm 1 x Ø 5.5 – 10.5 mm 1 x Ø 8.0 – 12.5 mm 3 x Ø 12 – 16.2 mm</p>	<p>Mounting cut-out For wall thickness of 1.5 – 2 mm (for mounting with snap-in hooks)</p>

Torque for the frame's mounting screw: 2.5 – 3 Nm

KES-GB-FDA 17/24
Dimensional diagram **Mounting cut-out**

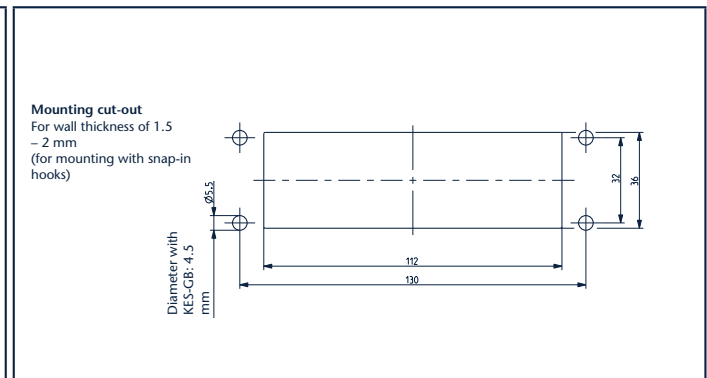
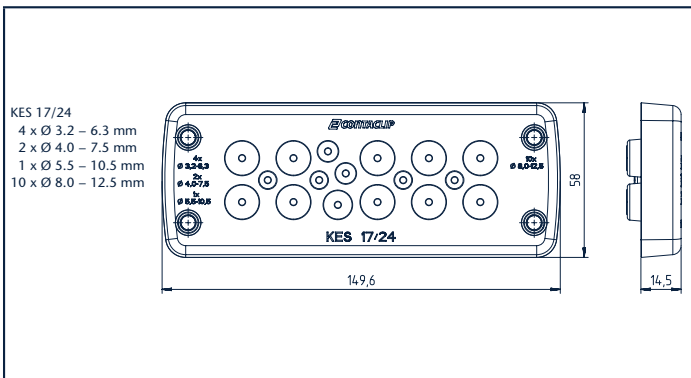

Torque for the frame's mounting screw: 2.5 – 3 Nm

KES-GB-FDA 20/24
Dimensional diagram **Mounting cut-out**

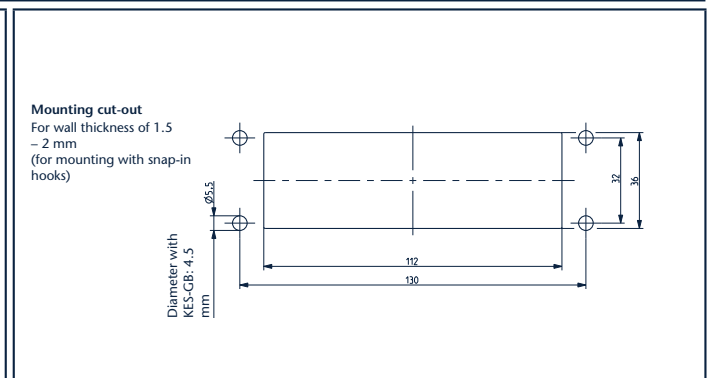
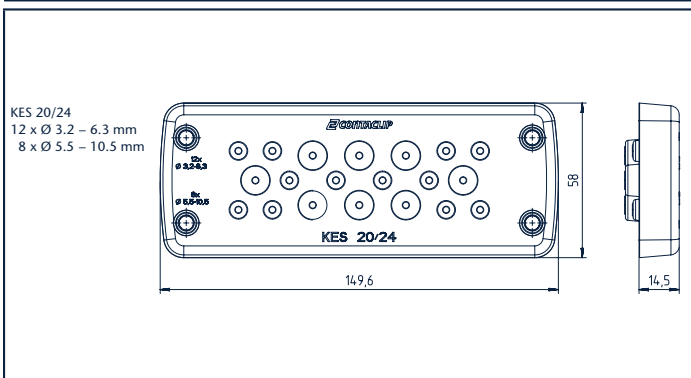

Torque for the frame's mounting screw: 2.5 – 3 Nm

KES-GB-FDA 21/24
Dimensional diagram **Mounting cut-out**

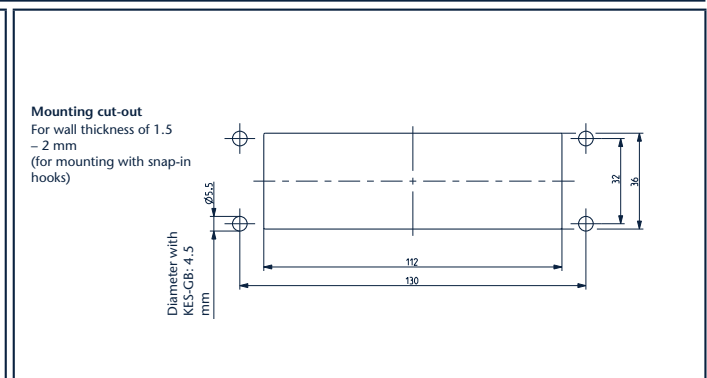
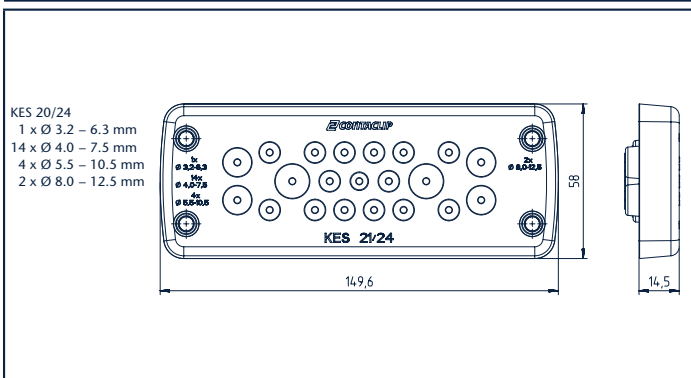

Torque for the frame's mounting screw: 2.5 – 3 Nm

KDS-GB-FDA KES 32/24
Dimensional diagram **Mounting cut-out**

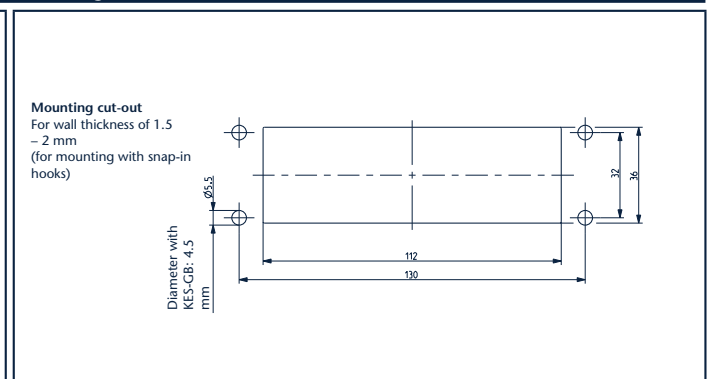
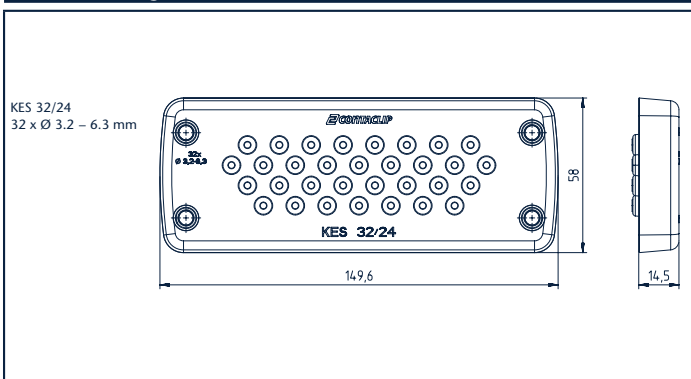

Torque for the frame's mounting screw: 2.5 – 3 Nm

KDS BW 1 actuating tool

Using the **KDS BW1** actuating tool, the seals can be conveniently mounted in and dismantled from the frame. The ergonomic grip and the special shape enable simple and precise installations, especially for cabling applications in confined spaces.



Actuating tool		KDS BW 1	
			
Type		KDS BW 1	
Cat. no.	Qty.	28622.0	1
Description		Actuating tool	
Material		PA 6.6	
Colour		varies	

KDSClick assortment box

The **KDSClick assortment box** is perfect for installation/maintenance work as well as innovative developments. The large selection of seals and inlays makes it easy to configure all the KDSClick systems to meet your needs.

KDSClick assortment box		KDSClick assortment box	
			
Type		KDSClick assortment box	
Cat. no.	Qty.	28764.0	1
Included in delivery		20 small dummy elements KDS-DE/B	
		220 small seals KDS-DE 2-14 mm	
		100 small multiple seals KDS-DE 4-6.5 mm	
		5 large dummy elements KDS-DEG/B	
		20 large seals KDS-DEG 14-21 mm	
		7 universal cone seals KDS-DE/K 2-24 mm	
		37 x inlay 1 to inlay 6	
		1 actuating tool KDS BW 1	
		1 plastic mini-calliper gauge	
		1 plastic electrical cabinet key	

KDS-EMV-SAB shield-connection rails

The **KDS-EMV-SAB** shield-connection rails, when used together with our different shield-connection clips, enable cables to be shielded in a quick, practical and uncomplicated process. The cables can be routed through the CONTA-CLIP cable entry systems into housing or electrical cabinets.

The **KDS-EMV-SAB** shield-connection rails are fastened on the inside of the electrical cabinet using screws, which are required for mounting the **KDS/KES** system. The appropriate shield clip (depending on the cable diameter) can then be snapped onto the shield-connection rail. The shield-connection clips/brackets are optionally available with a built-in strain relief function.

Shield-connection rails	KDS-EMV-SAB 1-4	KDS-EMV-SAB 6/10
		
Diagram		
Type	KDS-EMV-SAB 1-4	KDS-EMV-SAB 6/10
Cat. no.	28623.0	28624.0
Qty.	1	1
Suitable for	KDS-SR 1-4 BK	KDS-SR 6/10 BK
Shield-connection rails	KDS-EMV-SAB 8/16	KDS-EMV-SAB 10/24
		
Diagram		
Type	KDS-EMV-SAB 8/16	KDS-EMV-SAB 10/24
Cat. no.	28625.0	28626.0
Qty.	1	1
Suitable for	KDS-SR 8/16 BK	KDS-SR 10/24 BK KES.../24 KES-GB.../24
Shield-connection rails	KDS-FP-EMV-SAB 10/24	
		
Diagram		
Type	KDS-FP-EMV-SAB 10/24	
Cat. no.	28627.0	
Qty.	1	
Suitable for	KDS-FP 2X10/24 BK KDS-FP 3X10/24 BK	

KDS-BP blanking plates

Blanking plates		KDS-BP 8/16	KDS-BP 10/24
<p>The KDS-BP blanking plates provide a simple method for securely closing existing wall cut-outs for the KDS or KES systems. They are made of glass-fibre reinforced PA 6.6 material which enables excellent impact resistance. An injected, all-round gasket made of TPE ensures a reliable IP66 protective seal.</p>			
			
Type / colour		KDS-BP 8/16 BK	KDS-BP 10/24 BK
Cat. no.	Qty.	28508.4	28509.4
Description		Blanking plate	Blanking plate
Dimensions, mm			
Length x Width:		126 x 55	153 x 55
Installation height		11.5	11.5
Dimensions for mounting cut-out (mm)			
KDSClick		91 x 46	113.5 x 46
Standard cut-outs		86 x 36	112 x 36
Accessories			
Sheet-metal hole punch		BL-VA KDS-SR 8/16	BL-VA KDS-SR 10/24
Cat. no.	Qty.	28685.0	28686.0

KDS-BP Dimensional diagrams / Mounting cut-out for cable entries

KDS-BP 8/16
Dimensional diagram
Mounting cut-out

Also suitable for the CONTA-CLIP standard 46 x 91 mm cut-outs

Torque for the frame's mounting screw: 3 Nm

KDS-BP 10/24
Dimensional diagram
Mounting cut-out

Also suitable for the CONTA-CLIP standard 46 x 113.5 mm cut-outs

Torque for the frame's mounting screw: 3 Nm



Features

- Material: polyamide PA 6.6, glass-fibre reinforced | TPE
- Colour: black
- Flammability: UL 94 V-0
- Temperature range: -40 °C to +120 °C
- Halogen-free, silicone-free
- Protection: IP66

KDS/KES-VS seal plugs for all KDS and KES systems

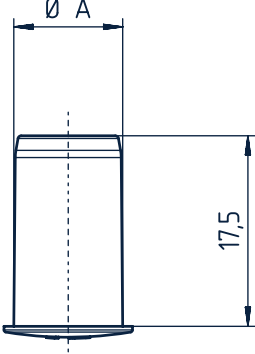
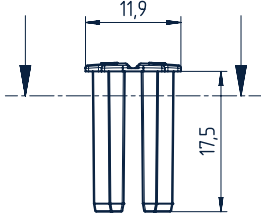
Seal plugs, screw frame	Type	Cat. no.	Qty.	Diameter (Ø A), mm	Head diameter, mm
<p>The KDS/KES-VS seal plugs allow you to reseal unused holes in KDS seals or in already pierced KES cable entries. The geometry of the head prevents splashed water or dust from penetrating from the outside. Thus, protection class IP66 is ensured.</p>	KDS-VS-SR BK	28779.4	100		
Seal plugs					
	KDS/KES-VS 2 WH	28781.7	25	2	5
	KDS/KES-VS 3 WH	28782.7	25	3	6
	KDS/KES-VS 4 WH	28783.7	25	4	7
	KDS/KES-VS 5 WH	28784.7	25	5	8
	KDS/KES-VS 6 WH	28785.7	25	6	9
	KDS/KES-VS 7 WH	28786.7	25	7	10
	KDS/KES-VS 8 WH	28787.7	25	8	11
	KDS/KES-VS 9 WH	28788.7	25	9	12
	KDS/KES-VS 10 WH	28789.7	25	10	13
	KDS/KES-VS 11 WH	28790.7	25	11	14
	KDS/KES-VS 12 WH	28791.7	25	12	15
	KDS/KES-VS 13 WH	28792.7	25	13	16
	KDS/KES-VS 14 WH	28793.7	25	14	17
	KDS/KES-VS 15 WH	28794.7	25	15	18
KDS/KES-VS 16 WH	28795.7	25	16	19	
KDS/KES-VS 17 WH	28796.7	25	17	20	
KDS/KES-VS 22 WH	28797.7	25	22	25	
Seal plugs AS interface cables					
	KDS-VS ASI/2 WH	28798.7	25	ASI	

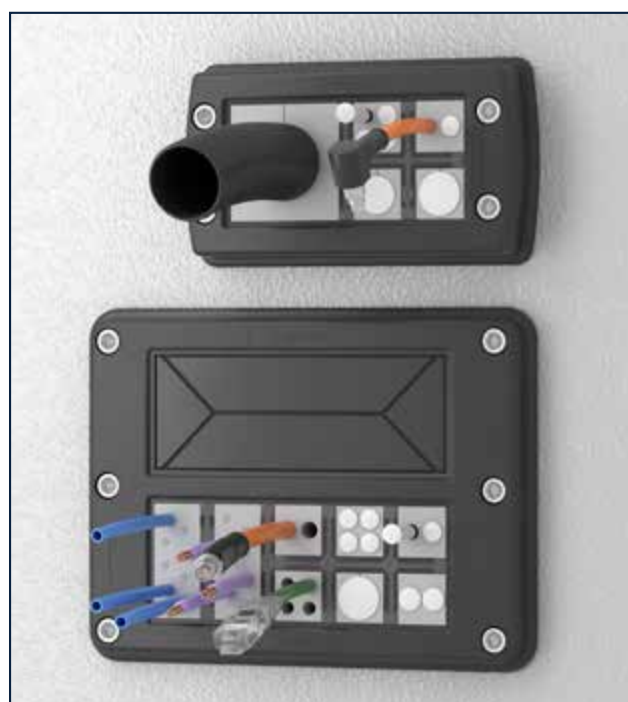

Features

- Material: polyamide PA 6.6 (KDS-VS-SR: TPE)
- Colour: white (KDS-VS-SR: black)
- Flammability: UL 94 V-0
- Temperature range: -40 °C to +120 °C
- Halogen-free, silicone-free
- Protection: IP66

Punching tools

The hydraulic hand pump, when used together with our hole punch, is perfectly suited for quickly producing precise chip-free cut-outs.

Rectangular punches are available for all **KDSClick** cable entry systems and for the **KES** cable entry system. The built-in punch-hole marking tip can be used to punch-mark the drill points clearly for screw-on attachments.

Sheet-metal hole punches are available in circular format for the sizes M20, M25, M32, M40, M50 and M63.

The hydraulic hand pump is also compatible with the hole punches from other popular manufacturers.



Hydraulic hand pump

Hydraulic hand pump

The hydraulic hand pump can be used to punch out openings for various cable feed-through and cable entry systems. The cylinder can be swivelled along 3 axes and rotated 360°, so that the cut-outs can also be punched in inconvenient places.



Your advantages

- Easy-to-use format without a tube
- Cylinder can rotate 360° and swivel along 3 axes
- Lightweight aluminium version (weight: 2 kg)
- Can also be used for inconvenient hard-to-reach locations



Features

Punching functionality for max. material thickness

- Round holes 82.0 mm, Steel 3 mm, VA 2 mm
- Square holes 68.0 x 68.0 mm, Steel 3 mm, VA 2 mm
- Rectangular holes 36.0 x 112.0 mm, Steel 3 mm, VA 2 mm

Hydraulic pump



Type	Hydraulic hand pump for sheet-metal hole punch	
Cat. no.	28679.0	Qty. 1
Included in delivery	1 hydraulic hand pump 1 hydraulic screw 19.0 x 130 mm 1 hydraulic screw 19.0 / 9.5 mm 1 spacer bushing 1 tube of anti-wear paste 1 HSS co-boring drill Multi-step drill, steps: 8 – 10 – 11.5 – 12.5 (M12) –14.5 –17.5 – 21 mm 1 transport box	

BL sheet-metal hole punch

The sheet-metal hole punch for the cable entry systems **KDS-SR**, **KDSI-SR**, **KDS-FP**, **KDS-FB**, **KDS-R/KDS-KV** and for the cable entry system **KES**. Using the sheet-metal punches, your desired cut-outs can be made in a few minutes without any chips or splintering. The built-in punch-hole marking tip can be used to punch-mark the drill points clearly for screw-on attachments. These sheet-metal punches are compatible with all common hydraulic pumps.

Assortment case



Punch, die, pulling axle and locknut in plastic case

Sets of sheet-metal hole punches		BL SET RECTANGLE Hyd.	BL SET M16-M63 Hyd.	BL-VA SET RECTANGLE Hyd.
Type		BL SET RECTANGLE Hyd.	BL SET M16-M63 Hyd.	BL-VA SET RECTANGLE Hyd.
Cat. no.	Qty.	28761.0	28766.0	28760.0
Included in delivery		Hydraulic pump + 4 x BL KDS-SR	Hydraulic pump + 7 x BL M16-M63	Hydraulic pump + 4 x BL-VA KDS-SR

Sheet-metal hole punch		BL KDS-SR 1-4	BL KDS-SR 6/10	BL KDS-SR 8/16
Type		BL KDS-SR 1-4	BL KDS-SR 6/10	BL KDS-SR 8/16
Cat. no.	Qty.	28674.0	28675.0	28676.0
Maximum wall thickness		2.0 mm with S 235 sheet metal	2.0 mm with S 235 sheet metal	2.0 mm with S 235 sheet metal
Dimensions of break-out hole		46 x 46 mm	68.5 x 46 mm	91 x 46 mm
Included in delivery		Punch, die, pulling axle, locknut, plastic case	Punch, die, pulling axle, locknut, plastic case	Punch, die, pulling axle, locknut, plastic case

VA sheet-metal hole punch		BL-VA KDS-SR 1-4	BL-VA KDS-SR 6/10	BL-VA KDS-SR 8/16
Type		BL-VA KDS-SR 1-4	BL-VA KDS-SR 6/10	BL-VA KDS-SR 8/16
Cat. no.	Qty.	28683.0	28684.0	28685.0
Maximum wall thickness		2.0 mm with stainless steel sheet	2.0 mm with stainless steel sheet	2.0 mm with stainless steel sheet
Dimensions of break-out hole		46 x 46 mm	68.5 x 46 mm	91 x 46 mm
Included in delivery		Punch, die, pulling axle, locknut, plastic case	Punch, die, pulling axle, locknut, plastic case	Punch, die, pulling axle, locknut, plastic case

Sheet-metal hole punch		BL KES	BL KDS-FP2	BL KDS-KV M20
Type		BL KES	BL KDS-FP2	BL KDS-KV M20
Cat. no.	Qty.	28744.0	28745.0	28746.0
Maximum wall thickness		2.0 mm with S 235 sheet metal	2.0 mm with S 235 sheet metal	2.0 mm with S 235 sheet metal
Dimensions of break-out hole		112 x 36 mm	110 x 131 mm	20.4 mm
Included in delivery		Punch, die, pulling axle, locknut, plastic case	Punch, die, pulling axle, locknut, plastic case	Punch, die

VA sheet-metal hole punch		BL-VA KES	BL-VA KDS-FP2	BL-VA KDS-KV M20
Type		BL-VA KES	BL-VA KDS-FP2	BL-VA KDS-KV M20
Cat. no.	Qty.	28752.0	28753.0	28754.0
Maximum wall thickness		2.0 mm with stainless steel sheet	2.0 mm with stainless steel sheet	2.0 mm with stainless steel sheet
Dimensions of break-out hole		112 x 36 mm	110 x 131 mm	20.4 mm
Included in delivery		Punch, die, pulling axle, locknut, plastic case	Punch, die, pulling axle, locknut, plastic case	Punch, die

BL KDS-KV sheet-metal hole punch



Hole punch for round cut-outs

BL KDS sheet-metal hole punch



Hole punch for rectangular cut-outs

BL-VA SET M16-M63 Hyd.				
BL-VA SET M16-M63 Hyd. 28765.0	1			
Hydraulic pump + 7 x B-VAL M16-M63				

BL KDS-SR 10/24	BL KDS-FB1	BL KDS-FB2	BL KDS-FB3	BL KDS-FB4
BL KDS-SR 10/24 28677.0	BL KDS-FB1 28734.0	BL KDS-FB2 28735.0	BL KDS-FB3 28736.0	BL KDS-FB4 28737.0
2.0 mm with S 235 sheet metal 113.5 x 46 mm	2.0 mm with S 235 sheet metal 46 x 24 mm	2.0 mm with S 235 sheet metal 68 x 24 mm	2.0 mm with S 235 sheet metal 89 x 24 mm	2.0 mm with S 235 sheet metal 111 x 24 mm
Punch, die, pulling axle, lock-nut, plastic case	Punch, die, pulling axle, lock-nut, plastic case	Punch, die, pulling axle, lock-nut, plastic case	Punch, die, pulling axle, lock-nut, plastic case	Punch, die, pulling axle, lock-nut, plastic case

BL-VA KDS-SR 10/24	BL-VA KDS-FB1	BL-VA KDS-FB2	BL-VA KDS-FB3	BL-VA KDS-FB4
BL-VA KDS-SR 10/24 28686.0	BL-VA KDS-FB1 28729.0	BL-VA KDS-FB2 28741.0	BL-VA KDS-FB3 28742.0	BL-VA KDS-FB4 28743.0
2.0 mm with stainless steel sheet 113.5 x 46 mm	2.0, with stainless steel sheet 46 x 24 mm	2.0, with stainless steel sheet 68 x 24 mm	2.0, with stainless steel sheet 89 x 24 mm	2.0 mm with stainless steel sheet 111 x 24 mm
Punch, die, pulling axle, lock-nut, plastic case	Punch, die, pulling axle, lock-nut, plastic case	Punch, die, pulling axle, lock-nut, plastic case	Punch, die, pulling axle, lock-nut, plastic case	Punch, die, pulling axle, lock-nut, plastic case

BL KDS-KV M25	BL KDS-KV M32	BL KDS-KV M40	BL KDS-KV M50	BL KDS-KV M63
BL KDS-KV M25 28747.0	BL KDS-KV M32 28748.0	BL KDS-KV M40 28749.0	BL KDS-KV M50 28750.0	BL KDS-KV M63 28751.0
2.0 mm with S 235 sheet metal 25.4 mm	2.0 mm with S 235 sheet metal 32.5 mm	2.0 mm with S 235 sheet metal 40.5 mm	2.0 mm with S 235 sheet metal 50.5 mm	2.0 mm with S 235 sheet metal 63.5 mm
Punch, die	Punch, die	Punch, die	Punch, die	Punch, die

BL-VA KDS-KV M25	BL-VA KDS-KV M32	BL-VA KDS-KV M40	BL-VA KDS-KV M50	BL-VA KDS-KV M63
BL-VA KDS-KV M25 28755.0	BL-VA KDS-KV M32 28756.0	BL-VA KDS-KV M40 28757.0	BL-VA KDS-KV M50 28758.0	BL-VA KDS-KV M63 28759.0
2.0 mm with stainless steel sheet 25.4 mm	2.0, with stainless steel sheet 32.5 mm	2.0, with stainless steel sheet 40.5 mm	2.0, with stainless steel sheet 50.5 mm	2.0 mm with stainless steel sheet 63.5 mm
Punch, die	Punch, die	Punch, die	Punch, die	Punch, die

Shield-connection clip

In the field of industrial process engineering, a high degree of interference immunity is required of electrical equipment. This is a critical factor affecting the availability of industrial measurement and control systems.

When constructing low-interference systems, both the cable shielding and the shielded ground are very important. The juncture where the cable shielding connects to the housing ground is a critical point. The connection should be low-ohm and should also feature minimal inductive resistance.

You should be certain that this connection can be established in a practical, simple and quick manner. CONTA-CLIP's **SAB/SSAB** shielding systems are one of the most comprehensive product portfolios on the market. They offer a perfect solution for any application.



Overview of installation types

Direct mounting



SAB.../D
Page 103



SABKM.../D
Page 102

C-rail mounting



SAB.../GWP
Page 107

Busbar mounting



SABKM.../SSCH/Z
Page 104



SABKMD.../SSCH/Z
Page 104



SAB
Page 105



SSAB
Page 106

Mounting on the DIN rail



SAB.../F
Page 109



SAB.../MF
Page 110



SABKM.../MF/35/Z
Page 108

SABK

Shield-connection bracket

The stripped cable is easily pushed into the **SABK** shield-connection clips. The spring force in the clip then ensures that the shield has a consistently good contact.

The large contact areas ensure excellent dissipation of interference current.

The **SABK** can be used with the mounting feet for various mounting platforms (e.g. on DIN rail, busbar, or for direct installation).





The **SABK** for the proper shield diameter is mounted by simply clipping it on (no tools required).



Your advantages

- The spring exerts continuous contact force on the cable shield
- High conductivity
- Very good dissipation of high-frequency interference current
- No tools are required: all sizes can be clipped onto the various mounting feet

Shield-connection bracket		SABK 3	SABK 6	SABK 8
				
Type		SABK 3	SABK 6	SABK 8
Cat. no.	Qty.	17970.0	17971.0	17972.0
Cable diameter Ø		1.5–3 mm	3–6 mm	6–8 mm
Material		Steel	Steel	Steel

Shield-connection bracket		SABK 11	SABK 16	SABK 30
				
Type	Qty.	SABK 11	SABK 16	SABK 30
Cat. no.		17973.0	17974.0	17997.0
Cable diameter Ø		8–11 mm	11–16 mm	17–30 mm
Material		Steel	Steel	Steel

SABKM

Shield-connection clip Multi

The **SABKM Multi** shield-connection clip differs from conventional shielding clips because of its two specially shaped legs.

These legs produce force on both sides so that a very large cable clamping range is attained. The stripped cable is easily pushed into the **SABKM**. The spring force in the clip then ensures that the shield has a consistently good contact.

The large contact surfaces ensure that any interference current is reliably dissipated.

The **SABKM** can be used with mounting feet for various mounting systems (e.g. on DIN rail, busbar, or for direct installation).

The **SABKM** for the proper shield diameter is mounted by simply clipping it on (no tools required).



Your advantages

- Fewer individual parts because of the large contact/clamping range
- Consistently good contact force due to spring action
- High conductivity
- Very good dissipation of high-frequency interference current
- No tools are required: all sizes can be clipped onto the various mounting feet

Shield-connection bracket		SABKM 12	SABKM 18
			
Type		SABKM 12	SABKM 18
Cat. no.	Qty.	17975.0	25
Cable diameter Ø		3–12 mm	7–18 mm
Material		Steel	Steel

MF-SABK/D

Mounting foot for direct installation

The mounting foot for the **MF-SABK/D** shield-connection clip serves as a universal carrier for the **SABK/SABKM** with clamping diameters from 1.5 mm to 30 mm. It can be installed directly (e.g. screwed directly onto a mounting plate). The suitable **SABK** can then be snapped in and the cable shield can be pressed in.



Your advantages

- Direct mounting using M4 screw
- Universal holder for SABK/SABKM, with cable clamping range from 1.5 mm to 30 mm
- Variable assembly options leads to less product types
- Less parts in your warehouse
- Very compact construction
- Cable tie can be used for strain relief

Installation of the SABKM shield-connection bracket on the MF-SABK/D mounting foot

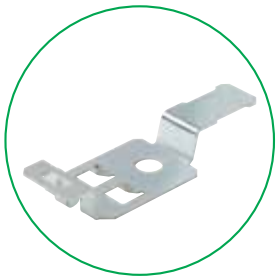

1. Screw on the mounting foot





2 Snap on your SABK



3. Press in the cable shield



4. Apply strain relief with cable ties

Mounting foot		MF/D M4/Z	MF/D M4
			
Mounting type		Direct mounting	Direct mounting
Description		With strain relief	Without strain relief
Type		MF/D M4/Z	MF/D M4
Cat. no.	Qty.	17977.0	27217.0
Material		Steel	Steel

RMF/D/Z M4

Row-mounted foot for direct mounting

The **RMF/D/Z M4** row-mounted foot for direct mounting serves as a universal carrier for up to 12 shield-connection clips with clamping diameters from 1.5 mm to 30 mm. The row-mounted foot can be shortened to the desired length by breaking it at one of its breakage points. Either screws or rivets can be used to secure it in position.





Your advantages

- Up to 12 cable shields can be attached to a single row-mounted foot.
- Space-saving installation on the mounting plate
- Universal holders for SABK/SABKM, with variable cable clamping ranges from 1.5 mm to 30 mm
- Breakage points permit versatile customization for your required number of cables.
- Less parts in your warehouse
- Very compact construction
- Cable tie can be used for strain relief

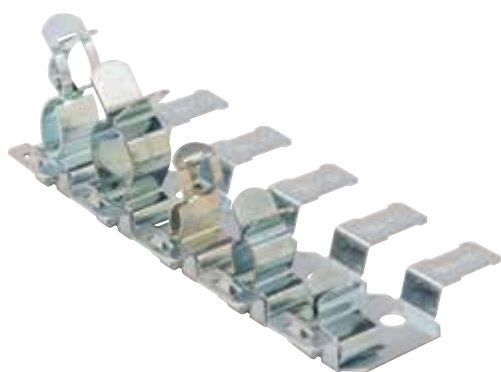
Installation of the SABKM shield-connection bracket on the MF-SABK/D mounting foot



Shield-connection bracket		Row-mounted foot	
			
Mounting type		Direct mounting	
Description		With strain relief	
Type		RMF/D M4/Z	
Cat. no.	Qty.	17986.0	10
Material		Steel	

MF-SABK/SSCH

Mounting foot for busbar installation

The **MF-SABK/SSCH** mounting foot for busbar mounting serves as a universal carrier for shield-connection clips with cable diameters from 1.5 mm to 30 mm. Simply snap the mounting foot onto the 10 x 3 mm busbar. Then snap in the corresponding shield-connection clip and press in the cable shield.



Your advantages

- Tool-free mounting onto busbars 10 x 3 mm
- For shield-connection brackets with a 1.5 mm to 30 mm clamping range
- Variable assembly options leads to less product types
- Less parts in your warehouse
- Very compact construction
- Cable tie can be used for strain relief

Installation of the SABKM shield-connection bracket on the MF-SABK/SSCH mounting foot

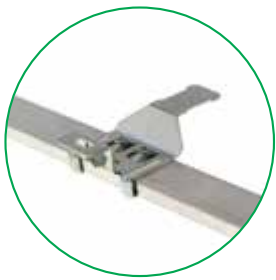

1. Screw on the mounting foot





2 Snap on your SABK



3. Press in the cable shield



4. Apply strain relief with cable ties

Mounting foot		MF-SABK/SSCH/Z	MF-SABK/SSCH
			
Mounting type		Busbar mounting	Busbar mounting
Description		With strain relief	Without strain relief
Type		MF-SABK/SSCH/Z	MF-SABK/SSCH
Cat. no.	Qty.	17979.0	27218.0
Material		Steel	Steel

MF-SABK/35

Mounting foot for DIN rail installation

The **MF-SABK/35/Z** mounting foot for **TS 35** DIN rails serves as a universal carrier for shield-connection clips with clamping diameters from 1.5 mm to 30 mm. Simply snap the mounting foot on the DIN rail. The properly sized shield-connection clip is then snapped on and the cable shield is pushed into the shield-connection clip. The variant with a strain relief clip provides cable ties to relieve the strain.



Your advantages

- Tool-free mounting on TS 35 DIN rail
- Universal holder for SABK/SABKM, with cable clamping range from 1.5 mm to 30 mm
- Variable assembly options leads to less product types
- Less parts in your warehouse
- Cable tie can be used for strain relief

Installation of the SABKM shield-connection bracket on the MF-SABK/35 mounting foot

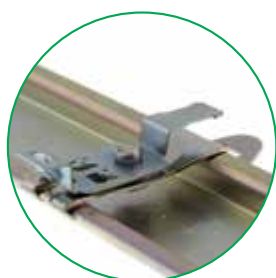

1. Screw on the mounting foot

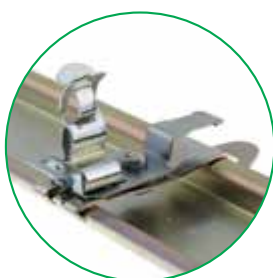



2 Snap on your SABK



3. Press in the cable shield

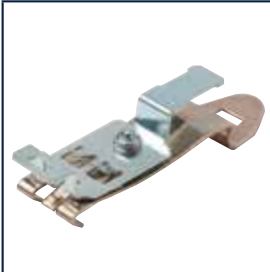

4. Apply strain relief with cable ties

Mounting foot		MF-SABK/35/Z	MF-SABK/35
			
Mounting type		Mounting on the DIN rail	Mounting on the DIN rail
Description		With strain relief	Without strain relief
Type		MF-SABK/35/Z	MF-SABK/35
Cat. no.	Qty.	17978.0	27261.0
Material		Steel	Steel

Multi SABKM.../D



Shield-connection clip for direct mounting

The **SABKM.../D** shield-connection clip can be installed directly (e.g. screwed directly onto a mounting plate). The cable shield must only be pressed into the **SABKM** in order to establish a reliable contact. The strain relief clip can be used with a cable tie to relieve strain at the cable sheath.



Your advantages

- Direct mounting using M4 screw
- Very compact construction
- Reduced product types when the Multi shield-connection bracket is used
- Cable tie can be used for strain relief

Shield-connection bracket	SABKM.../D	SABKM.../D/Z	SABK.../D
			
Mounting type	Direct mounting	Direct mounting	Direct mounting
Description	Without strain relief	With strain relief	Without strain relief
Type	SABKM 12/D M4	SABKM 12/D M4/Z	SABK 3/D M4
<i>Cat. no.</i>	27246.0	17984.0	27263.0
Qty.	10	10	10
Cable diameter Ø	3–12 mm	3–12 mm	1.5–3 mm
Drill hole diameter Ø	4.2 mm	4.2 mm	4.2 mm
Material	Steel	Steel	Steel
Type	SABKM 18/D M4	SABKM 18/D M4/Z	
<i>Cat. no.</i>	27247.0	17985.0	
Qty.	10	10	
Cable diameter Ø	7–18 mm	7–18 mm	
Drill hole diameter Ø	4.2 mm	4.2 mm	
Material	Steel	Steel	
Type	SABKM 30/D M4	SABKM 30/D M4/Z	
<i>Cat. no.</i>	27248.0	27220.0	
Qty.	10	10	
Cable diameter Ø	17–30 mm	17–30 mm	
Drill hole diameter Ø	4.2 mm	4.2 mm	
Material	Steel	Steel	
Type	SABKM 35/D M4		
<i>Cat. no.</i>	27256.0		
Qty.	5		
Cable diameter Ø	16–35 mm		
Drill hole diameter Ø	4.2 mm		
Material	Steel		
Type	SABKM 65/D M4		
<i>Cat. no.</i>	27257.0		
Qty.	5		
Cable diameter Ø	35–65 mm		
Drill hole diameter Ø	4.2 mm		
Material	Steel		

SAB.../D

Shield-connection clip for direct mounting



The **SAB.../D** shield-connection clip can be used for direct mounting installations. The force on the cable comes from a spring-pressure piece. This regulated pressure ensures a constant optimal contact. The **SAB.../D** can be installed with an M4 screw (included in delivery) directly to the mounting plate.

The **SAB 8/D M5** shield-connection clip comes with a special feature; it is equipped with a self-cutting M5 SW3 metal screw. As a result, less time is required to mount the clip on the mounting plate, since you only need to drill one 4.2-mm hole through the plate. The hole threads will then be cut into the plate by the screw.



Your advantages

- Quick snap-on or mounting of the shield-connection clip
- Different cable cross-sections can be accommodated by the elastic nature of the spring
- Easy to work with

Shield-connection clip	SAB.../D
 	
Mounting type	Direct mounting
Type	SAB 8/D
<i>Cat. no.</i>	1549.0
Qty.	10
Cable diameter Ø	3–8 mm
Screw	M 4
Material	Steel
Type	SAB 8/D/M5
<i>Cat. no.</i>	1526.0
Qty.	10
Cable diameter Ø	3–8 mm
Screw	M 4
Material	Steel
Type	SAB 13.5/D
<i>Cat. no.</i>	1550.0
Qty.	10
Cable diameter Ø	4–13.5 mm
Screw	M 4
Material	Steel
Type	SAB 20/D
<i>Cat. no.</i>	1551.0
Qty.	10
Cable diameter Ø	10–20 mm
Screw	M 4
Material	Steel
Type	SAB 32/D
<i>Cat. no.</i>	17361.0
Qty.	10
Cable diameter Ø	15–32 mm
Screw	M 4
Material	Steel

SABKM.../SSCH M4

Multi shield-connection clip on mounting foot for mounting to busbars

The Multi shield-connection clip on the mounting foot **SABKM.../SSCH M4** can be snapped onto a 10 x 3 mm busbar without any tools. The cable shield must only be pressed into the Multi shield-connection clip in order to establish a reliable contact. The strain relief clip can be used with a cable tie to relieve strain.



Your advantages

- Tool-free mounting onto busbars 10 x 3 mm
- Extremely compact construction
- Cable tie can be used for strain relief

Shield-connection bracket	SABKM.../SSCH	SABKM.../SSCH/Z	SABKMD.../SSCH	SABKMD.../SSCH/Z
Mounting type	Busbar mounting	Busbar mounting	Busbar mounting	Busbar mounting
Description	Without strain relief	With strain relief	Without strain relief	With strain relief
Type	SABKM 12/SSCH	SABKM 12/SSCH/Z	SABKD 1.5-3/SSCH	SABKD 1.5-3/SSCH/Z
Cat. no.	27224.0	17982.0	27250.0	27259.0
Qty.	10	10	10	10
Cable diameter Ø	3–12 mm	3–12 mm	1.5–3 mm	1.5–3 mm
Material	Steel	Steel	Steel	Steel
Type	SABKM 18/SSCH	SABKM 18/SSCH/Z	SABKD 3-6/SSCH	SABKD 3-6/SSCH/Z
Cat. no.	27225.0	17983.0	27251.0	27260.0
Qty.	10	10	10	10
Cable diameter Ø	7–18 mm	7–18 mm	3–6 mm	3–6 mm
Material	Steel	Steel	Steel	Steel
Type	SABKM 30/SSCH	SABKM 30/SSCH/Z	SABKD 6-8/SSCH	SABKD 6-8/SSCH/Z
Cat. no.	27226.0	27228.0	27252.0	27254.0
Qty.	10	10	10	10
Cable diameter Ø	17–30 mm	17–30 mm	6–8 mm	6–8 mm
Material	Steel	Steel	Steel	Steel
Type			SABKMD 3-12/SSCH	SABKMD 3-12/SSCH/Z
Cat. no.			27253.0	27255.0
Qty.			10	10
Cable diameter Ø			3–12 mm	3–12 mm
Material			Steel	Steel

SAB



Shield-connection clip for busbar mounting

The SAB shield-connection clips enable busbar mounting. After connecting the wiring, the shield-connection clip is mounted by simply swivelling in the **SAB** clip onto the busbar. The force on the cable comes from a spring-pressure piece. This regulated pressure ensures a constant optimal contact. This makes the **SAB** shield-connection clip very convenient to wire. Depending on the length of the terminal blocks, two or more **SH/SAB** busbar supports should be used. These mechanically connect the front busbar with the DIN rail (support).



Your advantages

- Quick snap-on or mounting of the shield-connection clip
- Different cable cross-sections can be accommodated by the elastic nature of the spring
- Easy to work with

Shield-connection clip	SAB
	
Mounting type	Busbar mounting
Type	SAB 8
<i>Cat. no.</i>	<i>1527.0</i>
Qty.	10
Cable diameter Ø	3–8 mm
Material	Steel
Type	SAB 13.5
<i>Cat. no.</i>	<i>1528.0</i>
Qty.	10
Cable diameter Ø	4–13.5 mm
Material	Steel
Type	SAB 20
<i>Cat. no.</i>	<i>1529.0</i>
Qty.	10
Cable diameter Ø	10–20 mm
Material	Steel
Type	SAB 32
<i>Cat. no.</i>	<i>17360.0</i>
Qty.	10
Cable diameter Ø	15–32 mm
Material	Steel

SSAB

Shield-connection clip for busbar mounting

The **SSAB** shield-connection clips enable busbar mounting. After wiring the terminal block, the shield-connection clip is mounted by simply swivelling in and tightening the knurled thumb screw. This makes the **SSAB** screw-shield-connection clip very convenient to wire. Depending on the length of the terminal blocks, two or more **SH/SAB** busbar supports should be used. These mechanically connect the front busbar with the DIN rail (support). The **SH1** busbar holders are used where a shield-connection system must be mounted directly onto a panel rather than a DIN rail. The 10x3mm busbars can be easily and quickly snapped on to these supports. In both cases, the contact with the earth or ground potential can be established with a **ZB** clamping yoke.



Your advantages

- Screw-on clip for simple retrofitting
- Knurled thumb screw, so no tools required
- Easy to work with
- Large shield surface
- Secure contact

Shield-connection clip for busbar mounting



SSAB



Mounting type	Busbar mounting
Type	SSAB 5
<i>Cat. no.</i>	<i>3694.0</i>
Qty.	10
Cable diameter Ø	2–5 mm
Torque	0.4 Nm
Material	Steel
Type	SSAB 8
<i>Cat. no.</i>	<i>3695.0</i>
Qty.	10
Cable diameter Ø	3–8 mm
Torque	0.6 Nm
Material	Steel
Type	SSAB 14
<i>Cat. no.</i>	<i>3696.0</i>
Qty.	10
Cable diameter Ø	3–14 mm
Torque	0.8 Nm
Material	Steel
Type	SSAB 20
<i>Cat. no.</i>	<i>3697.0</i>
Qty.	10
Cable diameter Ø	3–20 mm
Torque	0.8 Nm
Material	Steel
Type	SSAB 28
<i>Cat. no.</i>	<i>3698.0</i>
Qty.	10
Cable diameter Ø	5–28 mm
Torque	0.8 Nm
Material	Steel
Type	SSAB 35
<i>Cat. no.</i>	<i>3699.0</i>
Qty.	10
Cable diameter Ø	20–35 mm
Torque	1.8 Nm
Material	Steel

SAB.../GWP

Shield-connection clip for C-rail

The **SAB.../GWP** shield-connection clips enable mounting to a C-rail. The **SAB.../GWP** is attached to the threaded plate with an Allen (hex socket) screw. The force on the cable comes from a spring-pressure piece. This regulated pressure ensures a constant optimal contact with the DIN rail.



Your advantages

- Shield-connection clip is quickly mounted
- Different cable cross-sections can be accommodated by the elastic nature of the spring
- Easy to work with

Shield-connection clip for C-rail

SAB.../GWP



Mounting type	C-rail mounting
Type	SAB 8/GWP
Cat. no.	17356.0
Qty.	10
Cable diameter Ø	3–8 mm
Material	Steel
Type	SAB 13.5/GWP
Cat. no.	17357.0
Qty.	10
Cable diameter Ø	4–13.5 mm
Material	Steel
Type	SAB 20/GWP
Cat. no.	17358.0
Qty.	10
Cable diameter Ø	10–20 mm
Material	Steel
Type	SAB 32/GWP
Cat. no.	17359.0
Qty.	10
Cable diameter Ø	15–32 mm
Material	Steel

SABKM.../MF/35

Shield-connection clip for mounting to DIN rail

The Multi **SABKM.../MF/35** shield-connection clip on mounting foot can be snapped onto a **TS 35** DIN rail without using any tools. The cable shield must only be pressed into the Multi shield-connection clip in order to establish a reliable contact. The strain relief clip can be used with a cable tie to relieve strain.



Your advantages

- Simple tool-free installation
- Spring force provides consistently good contact to the cable shield
- Very good dissipation of high-frequency interference current
- Cable tie can be used for strain relief

Shield-connection bracket	SABK .../MF/35	SABK .../MF/35/Z
		
Mounting type	Mounting on the DIN rail	Mounting on the DIN rail
Description	Without strain relief	With strain relief
Type	SABK 3/MF/35	SABK 3/MF/35/Z
<i>Cat. no.</i>	27229.0	27240.0
Qty.	10	10
Cable diameter Ø	1.5–3 mm	1.5–3 mm
Type	SABK 6/MF/35	SABK 6/MF/35/Z
<i>Cat. no.</i>	27230.0	27241.0
Qty.	10	10
Cable diameter Ø	3–6 mm	3–6 mm
Type	SABK 8/MF/35	SABK 8/MF/35/Z
<i>Cat. no.</i>	27231.0	27242.0
Qty.	10	10
Cable diameter Ø	6–8 mm	6–8 mm
Type	SABK 11/MF/35	SABK 11/MF/35/Z
<i>Cat. no.</i>	27232.0	27243.0
Qty.	10	10
Cable diameter Ø	8–11 mm	8–11 mm
Type	SABK 16/MF/35	SABK 16/MF/35/Z
<i>Cat. no.</i>	27233.0	27244.0
Qty.	10	10
Cable diameter Ø	11–16 mm	11–16 mm
Type	SABK 30/MF/35	SABK 30/MF/35/Z
<i>Cat. no.</i>	27234.0	27245.0
Qty.	10	10
Cable diameter Ø	17–30 mm	17–30 mm
Type	SABKM 12/MF/35	SABKM 12/MF/35/Z
<i>Cat. no.</i>	27237.0	17980.0
Qty.	10	10
Cable diameter Ø	3–12 mm	3–12 mm
Type	SABKM 18/MF/35	SABKM 18/MF/35/Z
<i>Cat. no.</i>	27238.0	17981.0
Qty.	10	10
Cable diameter Ø	7–18 mm	7–18 mm
Type	SABKM 35/MF/35	
<i>Cat. no.</i>	27239.0	
Qty.	5	
Cable diameter Ø	16–35 mm	
Type	SABKM 65/MF/35	
<i>Cat. no.</i>	27258.0	
Qty.	5	
Cable diameter Ø	35–65 mm	

SAB.../F





Shield-connection clip for mounting to DIN rail

The **SAB.../F** shield-connection clips enable mounting to the DIN rail. The force exerted on the cable is regulated by a spring-loaded thrust piece. This ensures optimum contact at all times. The **SAB.../F** can be mounted directly to the **TS 35** DIN rail using the clamping foot and a mounting screw.



Your advantages

- Shield-connection clip is quickly mounted
- Different cable cross-sections can be accommodated by the elastic nature of the spring
- Easy to work with

Shield-connection clip	SAB 8/F	SAB 13.5/F	SAB 20/F
			
Mounting type	Mounting on the DIN rail	Mounting on the DIN rail	Mounting on the DIN rail
Type	SAB 8/F	SAB 13.5/F	SAB 20/F
Cat. no.	1571.0	1572.0	1573.0
Qty.	10	10	10
Cable diameter Ø	3–8 mm	4–13.5 mm	10–20 mm
Size (L x W x H), mm	18.5 x 13 x 26.5	22 x 19.5 x 32.5	27 x 13 x 26.5
Material	Steel	Steel	Steel

SAB.../MF

Shield-connection clip for mounting to DIN rail

The **SAB.../MF/35** shield-connection clips enable mounting to the DIN rail. The **SAB.../MF/35** is snapped on directly via the internal-spring **MF/35** mounting foot without using any tools. The force exerted on the cable is regulated by a spring-loaded thrust piece. This ensures that optimal contact is maintained with the DIN rail at all times.



Your advantages

- Simple tool-free installation
- Different cable cross-sections can be accommodated by the elastic nature of the spring
- Easy to work with
- /S version can be rotated and fixed in position using the fastening screw

Shield-connection clip	SAB.../MF/35	SAB.../MF/35/S
		
Mounting type	Mounting on the DIN rail	Mounting on the DIN rail
Type	SAB 8/MF/35	SAB 8/MF/35/S
<i>Cat. no.</i>	17038.0	17340.0
Qty.	10	10
Cable diameter Ø	3–8 mm	3–8 mm
Size (L x W x H), mm	18.5 x 13 x 26.5	18.5 x 13 x 26.5
Material	Steel	Steel
Type	SAB 13.5/MF/35	SAB 13.5/MF/35/S
<i>Cat. no.</i>	17039.0	17341.0
Qty.	10	10
Cable diameter Ø	4–13.5 mm	4–13.5 mm
Size (L x W x H), mm	22 x 19.5 x 32.5	22 x 19.5 x 32.5
Material	Steel	Steel
Type	SAB 20/MF/35	SAB 20/MF/35/S
<i>Cat. no.</i>	17040.0	17342.0
Qty.	10	10
Cable diameter Ø	10–20 mm	10–20 mm
Size (L x W x H), mm	27 x 24.5 x 40.5	27 x 24.5 x 40.5
Material	Steel	Steel
Type	SAB 32/MF/35	SAB 32/MF/35/S
<i>Cat. no.</i>	17363.0	17343.0
Qty.	10	10
Cable diameter Ø	15–32 mm	15–32 mm
Size (L x W x H), mm	53.2 x 33 x 71.5	53.2 x 33 x 71.5
Material	Steel	Steel



Busbar holder

Busbar holders are used for mounting all shield-connection clips with 10 x 3 mm busbars. These can be mounted quickly and flexibly according to your requirements. The **SH1** busbar holders are used where a shield-connection system must be mounted directly onto a panel rather than a DIN rail. The 10 x 3 mm busbars can be easily and quickly snapped on to these supports.

The **SH/SAB** busbar holders mechanically connect the preceding busbar with the DIN rail. Thus, the shield-connection clip can easily be extended directly to the terminal strip.

The **ES 35/K/ST** end support with its integrated receptacles enables you to easily mount 10 x 3 mm busbars directly above a **TS 35** DIN rail.

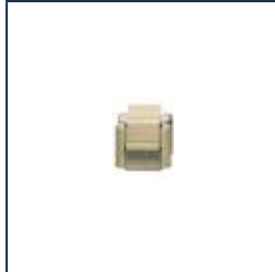
Depending on the length, two or more holders can be used. In both cases, the contact with the earth or ground potential can be established with a **ZB** clamping yoke.

Busbar holder			SH 1	SH SAB	ES 35/K/ST
					
Type/colour			SH 1 BG	SH SAB BG	ES 35/K/ST BG
<i>Cat. no.</i>		Qty.	2318.2	1530.2	2828.0
Size (L x W x H), mm			24 x 24 x 23.7	50 x 9.5 x 98	50 x 9.5 x 44
Material of cap/holder			PA 6.6 V-2	PA 6.6 V-2	PA 6.6 V-2
Accessories					
Mounting screw BS			BS M 4x8		
<i>Cat. no.</i>		Qty.	2262.0		
Busbar	Ssch	Copper	Ssch 10 x 3 CU	Ssch 10 x 3 CU	Ssch 10 x 3 CU
<i>Cat. no.</i>		Qty.	2129.0	2129.0	2129.0
Busbar	Ssch	Brass	Ssch 10 x 3 Ms	Ssch 10 x 3 Ms	Ssch 10 x 3 Ms
<i>Cat. no.</i>		Qty.	2128.0	2128.0	2128.0

Types and catalogue numbers, alphabetic

Type	Cat. no.	Page	Type	Cat. no.	Page	Type	Cat. no.	Page
B			KDS-DE 2X6.5 BK	28682.4	57	KDS-DEG 22-23 BK	28543.4	57
BL KDS-FB1	28734.0	93	KDS-DE 2x6.5 GR	28607.6	56	KDS-DEG 22-23 GR	28584.6	56
BL KDS-FB2	28735.0	93	KDS-DE 2x7 BK	28689.4	57	KDS-DEG 23-24 BK	28544.4	57
BL KDS-FB3	28736.0	93	KDS-DE 2x7 GR	28690.6	56	KDS-DEG 23-24 GR	28585.6	56
BL KDS-FB4	28737.0	93	KDS-DE 2x8 BK	28691.4	57	KDS-DEG 24-25 BK	28545.4	57
BL KDS-FP 2	28745.0	92	KDS-DE 2x8 GR	28692.6	56	KDS-DEG 24-25 GR	28586.6	56
BL KDS-KV M20	28746.0	92	KDS-DE 3 BK	28697.4	57	KDS-DEG 25-26 BK	28546.4	57
BL KDS-KV M25	28747.0	93	KDS-DE 3 GR	28698.6	56	KDS-DEG 25-26 GR	28587.6	56
BL KDS-KV M32	28748.0	93	KDS-DE 3-4 BK	28523.4	57	KDS-DEG 26-27 BK	28547.4	57
BL KDS-KV M40	28749.0	93	KDS-DE 3-4 GR	28564.6	56	KDS-DEG 26-27 GR	28588.6	56
BL KDS-KV M50	28750.0	93	KDS-DE 3x5-6 BK	28687.4	57	KDS-DEG 27-28 BK	28548.4	57
BL KDS-KV M63	28751.0	93	KDS-DE 3x5-6 GR	28688.6	56	KDS-DEG 27-28 GR	28589.6	56
BL KDS-SR 1-4	28674.0	92	KDS-DE 4-5 BK	28524.4	57	KDS-DEG 28-29 BK	28549.4	57
BL KDS-SR 10/24	28677.0	93	KDS-DE 4-5 GR	28565.6	56	KDS-DEG 28-29 GR	28590.6	56
BL KDS-SR 6/10	28675.0	92	KDS-DE 4-5 BK	28524.4	57	KDS-DEG 29-30 BK	28550.4	57
BL KDS-SR 8/16	28676.0	92	KDS-DE 4X2-3 BK	28557.4	57	KDS-DEG 29-30 GR	28591.6	56
BL KES	28744.0	92	KDS-DE 4X2-3 GR	28597.6	56	KDS-DEG 30-31 BK	28551.4	57
BL SET M16-M63	28766.0	92	KDS-DE 4X3-4 BK	28558.4	57	KDS-DEG 30-31 GR	28592.6	56
BL SET rectangle	28761.0	92	KDS-DE 4X3-4 GR	28598.6	56	KDS-DEG 31-32 BK	28552.4	57
BL-VA KDS-FB1	28729.0	93	KDS-DE 4x4.5 BK	28681.4	57	KDS-DEG 31-32 GR	28593.6	56
BL-VA KDS-FB2	28741.0	93	KDS-DE 4x4.5 GR	28606.6	56	KDS-DEG 32-33 BK	28601.4	57
BL-VA KDS-FB3	28742.0	93	KDS-DE 4X5 BK	28672.4	57	KDS-DEG 32-33 GR	28594.6	56
BL-VA KDS-FB4	28743.0	93	KDS-DE 4X5 GR	28673.6	56	KDS-DEG 33-34 BK	28730.4	57
BL-VA KDS-FP 2	28753.0	92	KDS-DE 4x6 BK	28763.4	57	KDS-DEG 33-34 GR	28731.6	56
BL-VA KDS-KV M20	28754.0	92	KDS-DE 4x6 GR	28762.6	56	KDS-DEG 34-35 BK	28732.4	57
BL-VA KDS-KV M25	28755.0	93	KDS-DE 5-6 BK	28525.4	57	KDS-DEG 34-35 GR	28733.6	56
BL-VA KDS-KV M32	28756.0	93	KDS-DE 5-6 GR	28566.6	56	KDS-DEG/B BK	28534.4	57
BL-VA KDS-KV M40	28757.0	93	KDS-DE 6-7 BK	28526.4	57	KDS-DEG/B GR	28575.6	56
BL-VA KDS-KV M50	28758.0	93	KDS-DE 6-7 GR	28567.6	56	KDS-DEG/K 7-24 BK	28554.4	57
BL-VA KDS-KV M63	28759.0	93	KDS-DE 7-8 BK	28527.4	57	KDS-DES 2X10.5 GR	28800.6	59
BL-VA KDS-SR 1-4	28683.0	92	KDS-DE 7-8 GR	28568.6	56	KDS-DES 3X8.5 GR	28802.6	59
BL-VA KDS-SR 10/24	28686.0	93	KDS-DE 8-9 BK	28528.4	57	KDS-DES 3X9.5 GR	28801.6	59
BL-VA KDS-SR 6/10	28684.0	92	KDS-DE 8-9 GR	28569.6	56	KDS-DES 4X7.5 GR	28803.6	59
BL-VA KDS-SR 8/16	28685.0	92	KDS-DE 9-10 BK	28529.4	57	KDS-DES 7X6.5 GR	28804.6	59
BL-VA KES	28752.0	92	KDS-DE 9-10 GR	28570.6	56	KDS-DES 8X4.5 GR	28806.6	59
BL-VA SET M16-M63	28765.0	93	KDS-DE-FB1/A GR	28713.6	52	KDS-DES 8X5.5 GR	28805.6	59
BL-VA SET rectangle	28760.0	92	KDS-DE-FB1/B GR	28714.6	52	KDS-EMV-SAB 1-4	28623.0	87
BS M 4x8	2262.0	111	KDS-DE-FB1/C GR	28715.6	52	KDS-EMV-SAB 10/24	28626.0	87
			KDS-DE-FB1/D GR	28716.6	53	KDS-EMV-SAB 6/10	28624.0	87
			KDS-DE-FB1/E GR	28717.6	53	KDS-EMV-SAB 8/16	28625.0	87
			KDS-DE-FB1/F GR	28718.6	53	KDS-FP 2x10/24 BK	28660.4	28
			KDS-DE-FB2/A GR	28719.6	53	KDS-FP 3x10/24 BK	28661.4	28
			KDS-DE-FB2/B GR	28720.6	52	KDS-FP-AD/UL YE	28665.8	28
			KDS-DE-FB2/C GR	28721.6	52	KDS-FP-EMV-SAB 10/24	28627.0	87
			KDS-DE-FB2/D GR	28722.6	52	KDS-FP-IVR OG	28664.3	28
			KDS-DE-FB2/E GR	28723.6	53	KDS-GM 20 BK	28616.4	36
			KDS-DE-FB2/F GR	28724.6	53	KDS-GM 25 BK	28617.4	36
			KDS-DE-FB3/A GR	28725.6	53	KDS-GM 32 BK	28618.4	36
			KDS-DE-FB3/B GR	28726.6	53	KDS-GM 40 BK	28619.4	37
			KDS-DE-FB3/C GR	28739.6	52	KDS-GM 50 BK	28620.4	37
			KDS-DE-FB4/A GR	28727.6	52	KDS-GM 63 BK	28621.4	37
			KDS-DE-FB4/B GR	28728.6	52	KDS-Inlay 1 BK	28516.4	14
			KDS-DE-FB4/C GR	28740.6	53	KDS-Inlay 2 BK	28517.4	14
			KDS-DE/1XASI BK	28559.4	57	KDS-Inlay 4 BK	28518.4	14
			KDS-DE/1XASI GR	28599.6	56	KDS-Inlay 6 BK	28519.4	14
			KDS-DE/2XASI BK	28560.4	57	KDS-IVR 1-4 BK	28507.4	22
			KDS-DE/2XASI GR	28600.6	56	KDS-IVR 6/10 BK	28501.4	22
			KDS-DE/B BK	28520.4	57	KDS-IVR 8/16 BK	28503.4	22
			KDS-DE/B GR	28561.6	56	KDS-IVR 10/24 BK	28505.4	22
			KDS-DE/K 2-11 BK	28553.4	57	KDS-KV M20 BK	28610.4	44
			KDS-DEG 14-15 BK	28535.4	57	KDS-KV M25 BK	28611.4	44
			KDS-DEG 14-15 GR	28576.6	56	KDS-KV M32 BK	28612.4	44
			KDS-DEG 15-16 BK	28536.4	57	KDS-KV M40 BK	28613.4	45
			KDS-DEG 15-16 GR	28577.6	56	KDS-KV M50 BK	28614.4	45
			KDS-DEG 16-17 BK	28537.4	57	KDS-KV M63 BK	28615.4	45
			KDS-DEG 16-17 GR	28578.6	56	KDS-R 20-32 BK	28770.4	36
			KDS-DEG 17-18 BK	28538.4	57	KDS-R 40-63 BK	28774.4	37
			KDS-DEG 17-18 GR	28579.6	56	KDS-RGA M20 BK	28771.4	36
			KDS-DEG 18-19 BK	28539.4	57	KDS-RGA M25 BK	28772.4	36
			KDS-DEG 18-19 GR	28580.6	56	KDS-RGA M32 BK	28773.4	36
			KDS-DEG 19-20 BK	28540.4	57	KDS-RGA M40 BK	28775.4	37
			KDS-DEG 19-20 GR	28581.6	56	KDS-RGA M50 BK	28776.4	37
			KDS-DEG 20-21 BK	28541.4	57	KDS-RGA M63 BK	28777.4	37
			KDS-DEG 20-21 GR	28582.6	56	KDS-Set 1-4 BK	28602.4	22
			KDS-DEG 21-22 BK	28542.4	57	KDS-Set 10/24 BK	28605.4	22
			KDS-DEG 21-22 GR	28583.6	56			

Type	Cat. no.	Page	Type	Cat. no.	Page	Type	Cat. no.	Page
KDS-Set 6/10 BK	28603.4	22	KES-E 42/24 A GR	28816.6	72	SAB 20	1529.0	105
KDS-Set 8/16 BK	28604.4	22	KES-E 42/24 B GR	28846.6	72	SAB 20/D	1551.0	103
KDS-SR 1-4 BK	28506.4	22	KES-E 48/24 A GR	28817.6	72	SAB 20/F	1573.0	109
KDS-SR 10/24 BK	28504.4	22	KES-E 48/24 B GR	28847.6	72	SAB 20/GWP	17358.0	107
KDS-SR 6/10 BK	28500.4	22	KES-E 50/24 A GR	28818.6	72	SAB 20/MF/35	17040.0	110
KDS-SR 8/16 BK	28502.4	22	KES-E 50/24 B GR	28848.6	72	SAB 20/MF/35/S	17342.0	110
KDS-SR-FB1/A BK	28700.4	48	KES-E-R 50/11 A GR	28830.6	76	SAB 32	17360.0	105
KDS-SR-FB2/A BK	28701.4	48	KES-E-R 50/11 B GR	28860.6	76	SAB 32/D	17361.0	103
KDS-SR-FB2/B BK	28702.4	48	KES-E-R 50/12 A GR	28831.6	76	SAB 32/GWP	17359.0	107
KDS-SR-FB3/A BK	28703.4	49	KES-E-R 50/12 B GR	28861.6	76	SAB 32/MF/35	17363.0	110
KDS-SR-FB3/B BK	28704.4	49	KES-E-R 50/16 A GR	28832.6	76	SAB 32/MF/35/S	17343.0	110
KDS-SR-FB3/C BK	28705.4	49	KES-E-R 50/16 B GR	28862.6	76	SAB 8	1527.0	105
KDS-SR-FB3/D BK	28706.4	49	KES-E-R 50/18 A GR	28833.6	76	SAB 8/D	1549.0	103
KDS-SR-FB4/A BK	28707.4	48	KES-E-R 50/18 B GR	28863.6	76	SAB 8/D/M5	1526.0	103
KDS-SR-FB4/B BK	28708.4	48	KES-E-R 50/20 A GR	28834.6	76	SAB 8/F	1571.0	109
KDS-SR-FB4/C BK	28709.4	48	KES-E-R 50/20 B GR	28864.6	76	SAB 8/GWP	17356.0	107
KDS-SR-FB4/D BK	28710.4	49	KES-E-R 50/35 A GR	28835.6	76	SAB 8/MF/35	17038.0	110
KDS-SR-FB4/E BK	28711.4	49	KES-E-R 50/35 B GR	28865.6	76	SAB 8/MF/35/S	17340.0	110
KDS-SR-FB4/F BK	28712.4	49	KES-E-R 50/9 A GR	28829.6	76	SABK 11	17973.0	96
KDS-VS-SR BK	28779.4	89	KES-E-R 50/9 B GR	28859.6	76	SABK 11/MF/35	27232.0	108
KDS/KES-VS 10 WH	28789.7	89	KES-GB 13/24 BK	28640.4	66	SABK 11/MF/35/Z	27243.0	108
KDS/KES-VS 11 WH	28790.7	89	KES-GB 13/24 GR	28640.6	66	SABK 16	17974.0	96
KDS/KES-VS 12 WH	28791.7	89	KES-GB 14/24 BK	28641.4	66	SABK 16/MF/35	27233.0	108
KDS/KES-VS 13 WH	28792.7	89	KES-GB 14/24 GR	28641.6	66	SABK 16/MF/35/Z	27244.0	108
KDS/KES-VS 14 WH	28793.7	89	KES-GB 16-1/24 BK	28643.4	67	SABK 3	17970.0	96
KDS/KES-VS 15 WH	28794.7	89	KES-GB 16-1/24 GR	28643.6	67	SABK 3/D M4	27263.0	102
KDS/KES-VS 16 WH	28795.7	89	KES-GB 16/24 BK	28642.4	66	SABK 3/MF/35	27229.0	108
KDS/KES-VS 17 WH	28796.7	89	KES-GB 16/24 GR	28642.6	66	SABK 3/MF/35/Z	27240.0	108
KDS/KES-VS 2 WH	28781.7	89	KES-GB 17/24 BK	28644.4	67	SABK 30	17997.0	96
KDS/KES-VS 22 WH	28797.7	89	KES-GB 17/24 GR	28644.6	67	SABK 30/MF/35	27234.0	108
KDS/KES-VS 3 WH	28782.7	89	KES-GB 20/24 BK	28645.4	67	SABK 30/MF/35/Z	27245.0	108
KDS/KES-VS 4 WH	28783.7	89	KES-GB 20/24 GR	28645.6	67	SABK 6	17971.0	96
KDS/KES-VS 5 WH	28784.7	89	KES-GB 21/24 BK	28646.4	67	SABK 6/MF/35	27230.0	108
KDS/KES-VS 6 WH	28785.7	89	KES-GB 21/24 GR	28646.6	67	SABK 6/MF/35/Z	27241.0	108
KDS/KES-VS 7 WH	28786.7	89	KES-GB 32/24 BK	28647.4	67	SABK 8	17972.0	96
KDS/KES-VS 8 WH	28787.7	89	KES-GB 32/24 GR	28647.6	67	SABK 8/MF/35	27231.0	108
KDS/KES-VS 9 WH	28788.7	89	KES-GB-FDA 13/24 BU	28900.5	82	SABK 8/MF/35/Z	27242.0	108
KDS/KES-VS ASI/2 WH	28798.7	89	KES-GB-FDA 14/24 BU	28901.5	82	SABKD 1.5-3/SSCH	27250.0	104
KDSI-AD 10/24 BK	28888.4	14	KES-GB-FDA 16-1/24 BU	28903.5	83	SABKD 1.5-3/SSCH/Z	27259.0	104
KDSI-AD 8/16 BK	28887.4	14	KES-GB-FDA 16/24 BU	28902.5	82	SABKD 3-6/SSCH	27251.0	104
KDSI-AD 1-4 BK	28885.4	14	KES-GB-FDA 17/24 BU	28904.5	83	SABKD 3-6/SSCH/Z	27260.0	104
KDSI-AD 6/10 BK	28886.4	14	KES-GB-FDA 20/24 BU	28905.5	83	SABKD 6-8/SSCH	27252.0	104
KDSI-AVR BK	28894.4	14	KES-GB-FDA 21/24 BU	28906.5	83	SABKD 6-8/SSCH/Z	27254.0	104
KDSI-SET 1-4 BK	28890.4	14	KES-GB-FDA 32/24 BU	28907.5	83	SABKM 12	17975.0	97
KDSI-SET 10/24 BK	28893.4	14	KES-R 13/24 BK	28650.4	66	SABKM 12/D M4	27246.0	102
KDSI-SET 6/10 BK	28891.4	14	KES-R 13/24 GR	28650.6	66	SABKM 12/D M4/Z	17984.0	102
KDSI-SET 8/16 BK	28892.4	14	KES-R 14/24 BK	28651.4	66	SABKM 12/MF/35	27237.0	108
KDSI-SR 1-4 BK	28880.4	14	KES-R 14/24 GR	28651.6	66	SABKM 12/MF/35/Z	17980.0	108
KDSI-SR 10/24 BK	28883.4	14	KES-R 16-1/24 BK	28653.4	67	SABKM 12/SSCH	27224.0	104
KDSI-SR 6/10 BK	28881.4	14	KES-R 16-1/24 GR	28653.6	67	SABKM 12/SSCH/Z	17982.0	104
KDSI-SR 8/16 BK	28882.4	14	KES-R 16/24 BK	28652.4	66	SABKM 18	17976.0	97
KES 13/24 BK	28630.4	66	KES-R 16/24 GR	28652.6	66	SABKM 18/D M4	27247.0	102
KES 13/24 GR	28630.6	66	KES-R 17/24 BK	28654.4	67	SABKM 18/D M4/Z	17985.0	102
KES 14/24 BK	28631.4	66	KES-R 17/24 GR	28654.6	67	SABKM 18/MF/35	27238.0	108
KES 14/24 GR	28631.6	66	KES-R 20/24 BK	28655.4	67	SABKM 18/MF/35/Z	17981.0	108
KES 16-1/24 BK	28633.4	67	KES-R 20/24 GR	28655.6	67	SABKM 18/SSCH	27225.0	104
KES 16-1/24 GR	28633.6	67	KES-R 21/24 BK	28656.4	67	SABKM 18/SSCH/Z	17983.0	104
KES 16/24 BK	28632.4	66	KES-R 21/24 GR	28656.6	67	SABKM 30/D M4	27248.0	102
KES 16/24 GR	28632.6	66	KES-R 32/24 BK	28657.4	67	SABKM 30/D M4/Z	27220.0	102
KES 17/24 BK	28634.4	67	KES-R 32/24 GR	28657.6	67	SABKM 30/SSCH	27226.0	104
KES 17/24 GR	28634.6	67				SABKM 30/SSCH/Z	27228.0	104
KES 20/24 BK	28635.4	67				SABKM 35/D M4	27256.0	102
KES 20/24 GR	28635.6	67	M			SABKM 35/MF/35	27239.0	108
KES 21/24 BK	28636.4	67	MF-SABK/35	27261.0	101	SABKM 65/D M4	27257.0	102
KES 21/24 GR	28636.6	67	MF-SABK/35/Z	17978.0	101	SABKM 65/MF/35	27258.0	108
KES 32/24 BK	28637.4	67	MF-SABK/SSCH	27218.0	100	SABKMD 3-12/SSCH	27253.0	104
KES 32/24 GR	28637.6	67	MF-SABK/SSCH/Z	17979.0	100	SABKMD 3-12/SSCH/Z	27255.0	104
KES-E 12/24 A GR	28810.6	72	MF/D M4	27217.0	98	SH 1 BG	2318.2	111
KES-E 12/24 B GR	28840.6	72	MF/D M4/Z	17977.0	98	SH SAB BG	1530.2	111
KES-E 14/24 A GR	28811.6	72				KDSClick assortment box	28764.0	86
KES-E 14/24 B GR	28841.6	72	R			SSAB 14	3696.0	106
KES-E 17/24 A GR	28812.6	72	RMF/D M4/Z	17986.0	99	SSAB 20	3697.0	106
KES-E 17/24 B GR	28842.6	72				SSAB 28	3698.0	106
KES-E 18/24 A GR	28813.6	72				SSAB 35	3699.0	106
KES-E 18/24 B GR	28843.6	72	S			SSAB 5	3694.0	106
KES-E 19/24 A GR	28814.6	72	SAB 13.5	1528.0	105	SSAB 8	3695.0	106
KES-E 19/24 B GR	28844.6	72	SAB 13.5/D	1550.0	103	Ssch 10x3 CU	2129.0	111
KES-E 26/24 A GR	28815.6	72	SAB 13.5/F	1572.0	109	Ssch 10x3 MS	2128.0	111
KES-E 26/24 B GR	28845.6	72	SAB 13.5/GWP	17357.0	107			
			SAB 13.5/MF/35	17039.0	110			
			SAB 13.5/MF/35/S	17341.0	110			

Types and catalogue numbers, numeric

Cat. no.	Type	Page	Cat. no.	Type	Page	Cat. no.	Type	Page
1			27232.0	SABK 11/MF/35	108	28551.4	KDS-DEG 30-31 BK	57
1526.0	SAB 8/D/M5	103	27233.0	SABK 16/MF/35	108	28552.4	KDS-DEG 31-32 BK	57
1527.0	SAB 8	105	27234.0	SABK 30/MF/35	108	28553.4	KDS-DE/K 2-11 BK	57
1528.0	SAB 13.5	105	27237.0	SABKM 12/MF/35	108	28554.4	KDS-DEG/K 7-24 BK	57
1529.0	SAB 20	105	27238.0	SABKM 18/MF/35	108	28555.4	KDS-DE 2X4-5 BK	57
1530.2	SH SAB BG	111	27239.0	SABKM 35/MF/35	108	28556.4	KDS-DE 2X5-6 BK	57
1549.0	SAB 8/D	103	27240.0	SABK 3/MF/35/Z	108	28557.4	KDS-DE 4X2-3 BK	57
1550.0	SAB 13.5/D	103	27241.0	SABK 6/MF/35/Z	108	28558.4	KDS-DE 4X3-4 BK	57
1551.0	SAB 20/D	103	27242.0	SABK 8/MF/35/Z	108	28559.4	KDS-DE/1XASI BK	57
1571.0	SAB 8/F	109	27243.0	SABK 11/MF/35/Z	108	28560.4	KDS-DE/2XASI BK	57
1572.0	SAB 13.5/F	109	27244.0	SABK 16/MF/35/Z	108	28561.6	KDS-DE/B GR	56
1573.0	SAB 20/F	109	27245.0	SABK 30/MF/35/Z	108	28562.6	KDS-DE 1.5-2 GR	56
2			27246.0	SABKM 12/D M4	102	28563.6	KDS-DE 2-3 GR	56
2128.0	Ssch 10x3 MS	111	27247.0	SABKM 18/D M4	102	28564.6	KDS-DE 3-4 GR	56
2129.0	Ssch 10x3 CU	111	27248.0	SABKM 30/D M4	102	28565.6	KDS-DE 4-5 GR	56
2262.0	BS M 4x8	111	27250.0	SABKD 1.5-3/SSCH	104	28566.6	KDS-DE 5-6 GR	56
2318.2	SH 1 BG	111	27251.0	SABKD 3-6/SSCH	104	28567.6	KDS-DE 6-7 GR	56
2828.0	ES 35/K/ST BG	111	27252.0	SABKD 6-8/SSCH	104	28568.6	KDS-DE 7-8 GR	56
3			27253.0	SABKMD 3-12/SSCH	104	28569.6	KDS-DE 8-9 GR	56
3694.0	SSAB 5	106	27254.0	SABKD 6-8/SSCH/Z	104	28570.6	KDS-DE 9-10 GR	56
3695.0	SSAB 8	106	27255.0	SABKMD 3-12/SSCH/Z	104	28571.6	KDS-DE 10-11 GR	56
3696.0	SSAB 14	106	27256.0	SABKM 35/D M4	102	28572.6	KDS-DE 11-12 GR	56
3697.0	SSAB 20	106	27257.0	SABKM 65/D M4	102	28573.6	KDS-DE 12-13 GR	56
3698.0	SSAB 28	106	27258.0	SABKM 65/MF/35	108	28574.6	KDS-DE 13-14 GR	56
3699.0	SSAB 35	106	27259.0	SABKD 1.5-3/SSCH/Z	104	28575.6	KDS-DEG/B GR	56
			27260.0	SABKD 3-6/SSCH/Z	104	28576.6	KDS-DEG 14-15 GR	56
			27261.0	MF-SABK/35	101	28577.6	KDS-DEG 15-16 GR	56
			27263.0	SABK 3/D M4	102	28578.6	KDS-DEG 16-17 GR	56
17			28			28579.6	KDS-DEG 17-18 GR	56
17038.0	SAB 8/MF/35	110	28500.4	KDS-SR 6/10 BK	22	28580.6	KDS-DEG 18-19 GR	56
17039.0	SAB 13.5/MF/35	110	28501.4	KDS-IVR 6/10 BK	22	28581.6	KDS-DEG 19-20 GR	56
17040.0	SAB 20/MF/35	110	28502.4	KDS-SR 8/16 BK	22	28582.6	KDS-DEG 20-21 GR	56
17340.0	SAB 8/MF/35/S	110	28503.4	KDS-IVR 8/16 BK	22	28583.6	KDS-DEG 21-22 GR	56
17341.0	SAB 13.5/MF/35/S	110	28504.4	KDS-SR 10/24 BK	22	28584.6	KDS-DEG 22-23 GR	56
17342.0	SAB 20/MF/35/S	110	28505.4	KDS-IVR 10/24 BK	22	28585.6	KDS-DEG 23-24 GR	56
17343.0	SAB 32/MF/35/S	110	28506.4	KDS-SR 1-4 BK	22	28586.6	KDS-DEG 24-25 GR	56
17356.0	SAB 8/GWP	107	28507.4	KDS-IVR 1-4 BK	22	28587.6	KDS-DEG 25-26 GR	56
17357.0	SAB 13.5/GWP	107	28508.4	KDS-IVR 1-4 BK	22	28588.6	KDS-DEG 26-27 GR	56
17358.0	SAB 20/GWP	107	28509.4	KDS-BP 8/16 BK	88	28589.6	KDS-DEG 27-28 GR	56
17359.0	SAB 32/GWP	107	28516.4	KDS-BP 10/24 BK	88	28590.6	KDS-DEG 28-29 GR	56
17360.0	SAB 32	105	28517.4	KDS-Inlay 1 BK	14	28591.6	KDS-DEG 29-30 GR	56
17361.0	SAB 32/D	103	28518.4	KDS-Inlay 2 BK	14	28592.6	KDS-DEG 30-31 GR	56
17363.0	SAB 32/MF/35	110	28519.4	KDS-Inlay 4 BK	14	28593.6	KDS-DEG 31-32 GR	56
17970.0	SABK 3	96	28520.4	KDS-Inlay 6 BK	14	28594.6	KDS-DEG 32-33 GR	56
17971.0	SABK 6	96	28521.4	KDS-DE/B BK	57	28595.6	KDS-DE 2X4-5 GR	56
17972.0	SABK 8	96	28522.4	KDS-DE 1.5-2 BK	57	28596.6	KDS-DE 2X5-6 GR	56
17973.0	SABK 11	96	28523.4	KDS-DE 2-3 BK	57	28597.6	KDS-DE 4X2-3 GR	56
17974.0	SABK 16	96	28524.4	KDS-DE 3-4 BK	57	28598.6	KDS-DE 4X3-4 GR	56
17975.0	SABKM 12	97	28525.4	KDS-DE 4-5 BK	57	28599.6	KDS-DE/1XASI GR	56
17976.0	SABKM 18	97	28526.4	KDS-DE 5-6 BK	57	28600.6	KDS-DE/2XASI GR	56
17977.0	MF/D M4/Z	98	28527.4	KDS-DE 6-7 BK	57	28601.4	KDS-DEG 32-33 BK	57
17978.0	MF-SABK/35/Z	101	28528.4	KDS-DE 7-8 BK	57	28602.4	KDS-Set 1-4 BK	22
17979.0	MF-SABK/SSCH/Z	100	28529.4	KDS-DE 8-9 BK	57	28603.4	KDS-Set 6/10 BK	22
17980.0	SABKM 12/MF/35/Z	108	28530.4	KDS-DE 9-10 BK	57	28604.4	KDS-Set 8/16 BK	22
17981.0	SABKM 18/MF/35/Z	108	28531.4	KDS-DE 10-11 BK	57	28605.4	KDS-Set 10/24 BK	22
17982.0	SABKM 12/SSCH/Z	104	28532.4	KDS-DE 11-12 BK	57	28606.6	KDS-DE 4x4.5 GR	56
17983.0	SABKM 18/SSCH/Z	104	28533.4	KDS-DE 12-13 BK	57	28607.6	KDS-DE 2x6.5 GR	56
17984.0	SABKM 12/D M4/Z	102	28534.4	KDS-DE 13-14 BK	57	28608.4	KDS-DE 14-15 BK	57
17985.0	SABKM 18/D M4/Z	102	28535.4	KDS-DEG/B BK	57	28609.6	KDS-DE 14-15 GR	56
17986.0	RMF/D M4/Z	99	28536.4	KDS-DEG 14-15 BK	57	28610.4	KDS-KV M20 BK	44
17997.0	SABK 30	96	28537.4	KDS-DEG 15-16 BK	57	28611.4	KDS-KV M25 BK	44
27			28538.4	KDS-DEG 16-17 BK	57	28612.4	KDS-KV M32 BK	44
27217.0	MF/D M4	98	28539.4	KDS-DEG 17-18 BK	57	28613.4	KDS-KV M40 BK	45
27218.0	MF-SABK/SSCH	100	28540.4	KDS-DEG 18-19 BK	57	28614.4	KDS-KV M50 BK	45
27220.0	SABKM 30/D M4/Z	102	28541.4	KDS-DEG 19-20 BK	57	28615.4	KDS-KV M63 BK	45
27224.0	SABKM 12/SSCH	104	28542.4	KDS-DEG 20-21 BK	57	28616.4	KDS-GM 20 BK	36
27225.0	SABKM 18/SSCH	104	28543.4	KDS-DEG 21-22 BK	57	28617.4	KDS-GM 25 BK	36
27226.0	SABKM 30/SSCH	104	28544.4	KDS-DEG 22-23 BK	57	28618.4	KDS-GM 32 BK	36
27228.0	SABKM 30/SSCH/Z	104	28545.4	KDS-DEG 23-24 BK	57	28619.4	KDS-GM 40 BK	37
27229.0	SABK 3/MF/35	108	28546.4	KDS-DEG 24-25 BK	57	28620.4	KDS-GM 50 BK	37
27230.0	SABK 6/MF/35	108	28547.4	KDS-DEG 25-26 BK	57	28621.4	KDS-GM 63 BK	37
27231.0	SABK 8/MF/35	108	28548.4	KDS-DEG 26-27 BK	57	28622.0	KDS BW 1	86
			28549.4	KDS-DEG 27-28 BK	57	28623.0	KDS-EMV-SAB 1-4	87
			28550.4	KDS-DEG 28-29 BK	57	28624.0	KDS-EMV-SAB 6/10	87
				KDS-DEG 29-30 BK	57	28625.0	KDS-EMV-SAB 8/16	87

Cat. no.	Type	Page	Cat. no.	Type	Page	Cat. no.	Type	Page
28626.0	KDS-EMV-SAB 10/24	87	28696.6	KDS-DE 2 GR	56	28782.7	KDS/KES-VS 3 WH	89
28627.0	KDS-FP-EMV-SAB 10/24	87	28697.4	KDS-DE 3 BK	57	28783.7	KDS/KES-VS 4 WH	89
28630.4	KES 13/24 BK	66	28698.6	KDS-DE 3 GR	56	28784.7	KDS/KES-VS 5 WH	89
28630.6	KES 13/24 GR	66	28700.4	KDS-SR-FB1/A BK	48	28785.7	KDS/KES-VS 6 WH	89
28631.4	KES 14/24 BK	66	28701.4	KDS-SR-FB2/A BK	48	28786.7	KDS/KES-VS 7 WH	89
28631.6	KES 14/24 GR	66	28702.4	KDS-SR-FB2/B BK	48	28787.7	KDS/KES-VS 8 WH	89
28632.4	KES 16/24 BK	66	28703.4	KDS-SR-FB3/A BK	49	28788.7	KDS/KES-VS 9 WH	89
28632.6	KES 16/24 GR	66	28704.4	KDS-SR-FB3/B BK	49	28789.7	KDS/KES-VS 10 WH	89
28633.4	KES 16-1/24 BK	67	28705.4	KDS-SR-FB3/C BK	49	28790.7	KDS/KES-VS 11 WH	89
28633.6	KES 16-1/24 GR	67	28706.4	KDS-SR-FB3/D BK	49	28791.7	KDS/KES-VS 12 WH	89
28634.4	KES 17/24 BK	67	28707.4	KDS-SR-FB4/A BK	48	28792.7	KDS/KES-VS 13 WH	89
28634.6	KES 17/24 GR	67	28708.4	KDS-SR-FB4/B BK	48	28793.7	KDS/KES-VS 14 WH	89
28635.4	KES 20/24 BK	67	28709.4	KDS-SR-FB4/C BK	48	28794.7	KDS/KES-VS 15 WH	89
28635.6	KES 20/24 GR	67	28710.4	KDS-SR-FB4/D BK	49	28795.7	KDS/KES-VS 16 WH	89
28636.4	KES 21/24 BK	67	28711.4	KDS-SR-FB4/E BK	49	28796.7	KDS/KES-VS 17 WH	89
28636.6	KES 21/24 GR	67	28712.4	KDS-SR-FB4/F BK	49	28797.7	KDS/KES-VS 22 WH	89
28637.4	KES 32/24 BK	67	28713.6	KDS-DE-FB1/A GR	52	28798.7	KDS/KES-VS ASI/2 WH	89
28637.6	KES 32/24 GR	67	28714.6	KDS-DE-FB1/B GR	52	28800.6	KDS-DES 2X10.5 GR	59
28640.4	KES-GB 13/24 BK	66	28715.6	KDS-DE-FB1/C GR	52	28801.6	KDS-DES 3X9.5 GR	59
28640.6	KES-GB 13/24 GR	66	28716.6	KDS-DE-FB1/D GR	53	28802.6	KDS-DES 3X8.5 GR	59
28641.4	KES-GB 14/24 BK	66	28717.6	KDS-DE-FB1/E GR	53	28803.6	KDS-DES 4X7.5 GR	59
28641.6	KES-GB 14/24 GR	66	28718.6	KDS-DE-FB1/F GR	53	28804.6	KDS-DES 7X6.5 GR	59
28642.4	KES-GB 16/24 BK	66	28719.6	KDS-DE-FB2/A GR	53	28805.6	KDS-DES 8X5.5 GR	59
28642.6	KES-GB 16/24 GR	66	28720.6	KDS-DE-FB2/B GR	52	28806.6	KDS-DES 8X4.5 GR	59
28643.4	KES-GB 16-1/24 BK	67	28721.6	KDS-DE-FB2/C GR	52	28810.6	KES-E 12/24 A GR	72
28643.6	KES-GB 16-1/24 GR	67	28722.6	KDS-DE-FB2/D GR	52	28811.6	KES-E 14/24 A GR	72
28644.4	KES-GB 17/24 BK	67	28723.6	KDS-DE-FB2/E GR	53	28812.6	KES-E 17/24 A GR	72
28644.6	KES-GB 17/24 GR	67	28724.6	KDS-DE-FB2/F GR	53	28813.6	KES-E 18/24 A GR	72
28645.4	KES-GB 20/24 BK	67	28725.6	KDS-DE-FB3/A GR	53	28814.6	KES-E 19/24 A GR	72
28645.6	KES-GB 20/24 GR	67	28726.6	KDS-DE-FB3/B GR	53	28815.6	KES-E 26/24 A GR	72
28646.4	KES-GB 21/24 BK	67	28727.6	KDS-DE-FB4/A GR	52	28816.6	KES-E 42/24 A GR	72
28646.6	KES-GB 21/24 GR	67	28728.6	KDS-DE-FB4/B GR	52	28817.6	KES-E 48/24 A GR	72
28647.4	KES-GB 32/24 BK	67	28729.0	BL-VA KDS-FB1	93	28818.6	KES-E 50/24 A GR	72
28647.6	KES-GB 32/24 GR	67	28730.4	KDS-DEG 33-34 BK	57	28829.6	KES-E-R 50/9 A GR	76
28650.4	KES-R 13/24 BK	66	28731.6	KDS-DEG 33-34 GR	56	28830.6	KES-E-R 50/11 A GR	76
28650.6	KES-R 13/24 GR	66	28732.4	KDS-DEG 34-35 BK	57	28831.6	KES-E-R 50/12 A GR	76
28651.4	KES-R 14/24 BK	66	28733.6	KDS-DEG 34-35 GR	56	28832.6	KES-E-R 50/16 A GR	76
28651.6	KES-R 14/24 GR	66	28734.0	BL KDS-FB1	93	28833.6	KES-E-R 50/18 A GR	76
28652.4	KES-R 16/24 BK	66	28735.0	BL KDS-FB2	93	28834.6	KES-E-R 50/20 A GR	76
28652.6	KES-R 16/24 GR	66	28736.0	BL KDS-FB3	93	28835.6	KES-E-R 50/35 A GR	76
28653.4	KES-R 16-1/24 BK	67	28737.0	BL KDS-FB4	93	28840.6	KES-E 12/24 B GR	72
28653.6	KES-R 16-1/24 GR	67	28739.6	KDS-DE-FB3/C GR	52	28841.6	KES-E 14/24 B GR	72
28654.4	KES-R 17/24 BK	67	28740.6	KDS-DE-FB4/C GR	53	28842.6	KES-E 17/24 B GR	72
28654.6	KES-R 17/24 GR	67	28741.0	BL-VA KDS-FB2	93	28843.6	KES-E 18/24 B GR	72
28655.4	KES-R 20/24 BK	67	28742.0	BL-VA KDS-FB3	93	28844.6	KES-E 19/24 B GR	72
28655.6	KES-R 20/24 GR	67	28743.0	BL-VA KDS-FB4	93	28845.6	KES-E 26/24 B GR	72
28656.4	KES-R 21/24 BK	67	28744.0	BL KES	92	28846.6	KES-E 42/24 B GR	72
28656.6	KES-R 21/24 GR	67	28745.0	BL KDS-FP 2	92	28847.6	KES-E 48/24 B GR	72
28657.4	KES-R 32/24 BK	67	28746.0	BL KDS-KV M20	92	28848.6	KES-E 50/24 B GR	72
28657.6	KES-R 32/24 GR	67	28747.0	BL KDS-KV M25	93	28859.6	KES-E-R 50/9 B GR	76
28660.4	KDS-FP 2x10/24 BK	28	28748.0	BL KDS-KV M32	93	28860.6	KES-E-R 50/11 B GR	76
28661.4	KDS-FP 3x10/24 BK	28	28749.0	BL KDS-KV M40	93	28861.6	KES-E-R 50/12 B GR	76
28664.3	KDS-FP-IVR OG	28	28750.0	BL KDS-KV M50	93	28862.6	KES-E-R 50/16 B GR	76
28665.8	KDS-FP-AD/UL YE	28	28751.0	BL KDS-KV M63	93	28863.6	KES-E-R 50/18 B GR	76
28670.4	KDS-DE 15-16 BK	57	28752.0	BL-VA KES	92	28864.6	KES-E-R 50/20 B GR	76
28671.6	KDS-DE 15-16 GR	56	28753.0	BL-VA KDS-FP 2	92	28865.6	KES-E-R 50/35 B GR	76
28672.4	KDS-DE 4X5 BK	57	28754.0	BL-VA KDS-KV M20	92	28880.4	KDSI-SR 1-4 BK	14
28673.6	KDS-DE 4X5 GR	56	28755.0	BL-VA KDS-KV M25	93	28881.4	KDSI-SR 6/10 BK	14
28674.0	BL KDS-SR 1-4	92	28756.0	BL-VA KDS-KV M32	93	28882.4	KDSI-SR 8/16 BK	14
28675.0	BL KDS-SR 6/10	92	28757.0	BL-VA KDS-KV M40	93	28883.4	KDSI-SR 10/24 BK	14
28676.0	BL KDS-SR 8/16	92	28758.0	BL-VA KDS-KV M50	93	28885.4	KDSI-AD 1-4 BK	14
28677.0	BL KDS-SR 10/24	93	28759.0	BL-VA KDS-KV M63	93	28886.4	KDSI-AD 6/10 BK	14
28679.0	Hydraulic hand pump for sheet-metal hole punch	91	28760.0	BL-VA SET rectangle	92	28887.4	KDSI-AD 8/16 BK	14
28681.4	KDS-DE 4x4.5 BK	57	28761.0	BL SET rectangle	92	28888.4	KDSI-AD 10/24 BK	14
28682.4	KDS-DE 2x6.5 BK	57	28762.6	KDS-DE 4x6 GR	56	28890.4	KDSI-Set 1-4 BK	14
28683.0	BL-VA KDS-SR 1-4	92	28763.4	KDS-DE 4x6 BK	57	28891.4	KDSI-Set 6/10 BK	14
28684.0	BL-VA KDS-SR 6/10	92	28764.0	KDSClick assortment box	86	28892.4	KDSI-Set 8/16 BK	14
28685.0	BL-VA KDS-SR 8/16	92	28765.0	BL-VA SET M16-M63	93	28893.4	KDSI-Set 10/24 BK	14
28686.0	BL-VA KDS-SR 10/24	93	28766.0	BL SET M16-M63	92	28894.4	KDSI-AVR BK	14
28687.4	KDS-DE 3x5-6 BK	57	28770.4	KDS-R 20-32 BK	36	28900.5	KES-GB-FDA 13/24 BU	82
28688.6	KDS-DE 3x5-6 GR	56	28771.4	KDS-RGA M20 BK	36	28901.5	KES-GB-FDA 14/24 BU	82
28689.4	KDS-DE 2x7 BK	57	28772.4	KDS-RGA M25 BK	36	28902.5	KES-GB-FDA 16/24 BU	82
28690.6	KDS-DE 2x7 GR	56	28773.4	KDS-RGA M32 BK	36	28903.5	KES-GB-FDA 16-1/24 BU	83
28691.4	KDS-DE 2x8 BK	57	28774.4	KDS-R 40-63 BK	37	28904.5	KES-GB-FDA 17/24 BU	83
28692.6	KDS-DE 2x8 GR	56	28775.4	KDS-RGA M40 BK	37	28905.5	KES-GB-FDA 20/24 BU	83
28693.4	KDS-DE 1.5 BK	57	28776.4	KDS-RGA M50 BK	37	28906.5	KES-GB-FDA 21/24 BU	83
28694.6	KDS-DE 1.5 GR	56	28777.4	KDS-RGA M63 BK	37	28907.5	KES-GB-FDA 32/24 BU	83
28695.4	KDS-DE 2 BK	57	28779.4	KDS-VS-SR BK	89			
			28781.7	KDS/KES-VS 2 WH	89			

Otto-Hahn-Str. 7
D-33161 Hövelhof,
Germany

Phone +49 (0) 5257 9833-0
Fax +49 (0) 5257 9833-33

info@conta-clip.com
www.conta-clip.com



Our products for your challenges:

01 CONTA-CONNECT
Terminal blocks
with push-in connection system
Cat. no. 98070.2

02 CONTA-CONNECT
Terminal blocks with screw connection
system and special purpose terminals
Cat. no. 98071.2

03 CONTA-CONNECT
Terminal blocks with tension-spring
connection system
Cat. no. 98072.2

04 CONTA-CONNECT
Installation materials and
other accessories for terminal blocks
Cat. no. 98073.2

05 CONTA-LABEL
Marking components
for thermal-transfer marking systems
Cat. no. 98074.2

06 CONTA-LABEL
Marking components
for ink-based marking systems
Cat. no. 98075.2

07 CONTA-BOX
Housings
Cat. no. 98076.2

08 CONTA-CABLE
KDS cable entries, KES cable entries,
SAB|SSAB|SABK shielding solutions
Cat. no. 98077.2

09 CONTA-ELECTRONICS
Electrical and electronic cabinet components
Cat. no. 98078.2

10 CONTA-CON
PCB terminals and connectors
Cat. no. 98079.2