

# HC-STA-D15-HLFS-1TTM20-ELC-AL - Housing



1424350

<https://www.phoenixcontact.com/au/products/1424350>

Please be informed that the data shown in this PDF document is generated from our online catalog. Please find the complete data in the user documentation. Our general terms of use for downloads are valid.



Sleeve housing D15, for single locking latch, material: Die-cast aluminum, salt water resistant, cable outlets: 1, straight, 1x M20, height: 56 mm, cable gland: none, Standard

## Commercial data

Item number	1424350
Packing unit	1 pc
Minimum order quantity	1 pc
Sales key	AF7APE
Product key	AF7APE
Catalog page	Page 525 (C-2-2019)
GTIN	4055626370866
Weight per piece (including packing)	95.3 g
Weight per piece (excluding packing)	95.3 g
Customs tariff number	85389099
Country of origin	CN

# HC-STA-D15-HLFS-1TTM20-ELC-AL - Housing



1424350

<https://www.phoenixcontact.com/au/products/1424350>

## Technical data

### Notes

General	For contact inserts HC-D15, A10
---------	---------------------------------

### Product properties

Product type	Housing with locking latch
Housing type	Sleeve housing
Product family	HC-STA-D
Application	Standard
Type	D15
No. of cable outlets	1
Type of the screw connection	1x M20
Type	Low design
Cable outlet	straight
Pg screw connection	none

### Dimensions

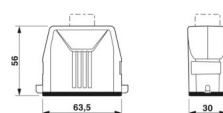
Dimensional drawing	
Width	30 mm
Height	56 mm
Length	63.5 mm

### Material specifications

Seal material	NBR, conductive
Housing material	Die-cast aluminum, salt water resistant
Housing surface material	uncoated

### Mechanical properties

#### Mechanical data

Type of the screw connection	1x M20
Locking type	Pin

### Environmental and real-life conditions

#### Ambient conditions

Degree of protection	IP66 IP67
Impact strength	IK08
Ambient temperature (operation)	-40 °C ... 125 °C

# HC-STA-D15-HLFS-1TTM20-ELC-AL - Housing

1424350

<https://www.phoenixcontact.com/au/products/1424350>



## Drawings

Dimensional drawing

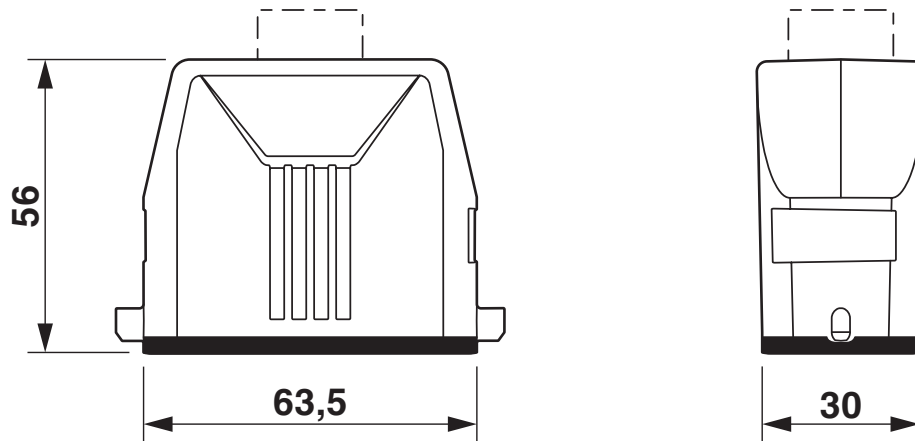

Dimensional drawing

# HC-STA-D15-HLFS-1TTM20-ELC-AL - Housing



1424350

<https://www.phoenixcontact.com/au/products/1424350>

## Approvals

To download certificates, visit the product detail page: <https://www.phoenixcontact.com/au/products/1424350>

**DNV**

Approval ID: TAE000037S



**cUL Recognized**

Approval ID: E255026



**UL Recognized**

Approval ID: E255026

# HC-STA-D15-HLFS-1TTM20-ELC-AL - Housing



1424350

<https://www.phoenixcontact.com/au/products/1424350>

## Classifications

### ECLASS

ECLASS-13.0

27440202

### ETIM

ETIM 9.0

EC000437

### UNSPSC

UNSPSC 21.0

31261500

# HC-STA-D15-HLFS-1TTM20-ELC-AL - Housing



1424350

<https://www.phoenixcontact.com/au/products/1424350>

## Environmental product compliance

### EU RoHS

Fulfills EU RoHS substance requirements	Yes, No exemptions
---	--------------------

### China RoHS

Environment friendly use period (EFUP)	EFUP-E
	No hazardous substances above the limits

### EU REACH SVHC

REACH candidate substance (CAS No.)	No substance above 0.1 wt%
-------------------------------------	----------------------------

Phoenix Contact 2025 © - all rights reserved  
<https://www.phoenixcontact.com>

PHOENIX CONTACT PTY Ltd  
Unit 7, 2-8 South Street  
Rydalmere NSW 2116  
1300 786 411  
[customerservice@phoenixcontact.com.au](mailto:customerservice@phoenixcontact.com.au)