

HC-STA-D07-SHCWS-1SGM20-PL-BK - Housing



1419268

<https://www.phoenixcontact.com/au/products/1419268>

Please be informed that the data shown in this PDF document is generated from our online catalog. Please find the complete data in the user documentation. Our general terms of use for downloads are valid.

Surface mounting housing D7, with single locking latch, material: PA, cable outlets: 1, straight, M20, height: 28 mm, cable gland: with, Standard, enclosed bottom



Commercial data

Item number	1419268
Packing unit	1 pc
Minimum order quantity	1 pc
Sales key	AF7APD
Product key	AF7APD
Catalog page	Page 516 (C-2-2019)
GTIN	4055626160191
Weight per piece (including packing)	31.9 g
Weight per piece (excluding packing)	31.7 g
Customs tariff number	85389099
Country of origin	CN

HC-STA-D07-SHCWS-1SGM20-PL-BK - Housing



1419268

<https://www.phoenixcontact.com/au/products/1419268>

Technical data

Notes

General	for contact inserts HC-A03, A04, D07, D08, Q02, Q03, Q04, Q05, Q07, Q12
---------	---

Product properties

Product type	Housing with locking latch
Housing type	Surface mounting housing
Product family	HC-STA-D07
Application	Standard
Type	D7
No. of cable outlets	1
Type of the screw connection	M20
Shielded	no
Cable outlet	straight
Pg screw connection	with

Dimensions

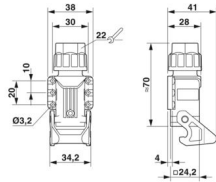
Dimensional drawing	
Width	38 mm
Height	28 mm
Length	24.2 mm
Hole diameter	3.2 mm

Material specifications

Flammability rating according to UL 94	V0 (Housing) V0 (Interlock)
Seal material	NBR
Housing material	PA
Locking latch material	PA

Mechanical properties

Mechanical data

Type of the screw connection	M20
Locking type	Latch

Cable/line

HC-STA-D07-SHCWS-1SGM20-PL-BK - Housing



1419268

<https://www.phoenixcontact.com/au/products/1419268>

External cable diameter	4 mm ... 10 mm
-------------------------	----------------

Connection data

External cable diameter	4 mm ... 10 mm
Tightening torque	0.5 Nm ... 0.8 Nm (for M3 mounting screws on the surface-mount housing)

Environmental and real-life conditions

Ambient conditions

Degree of protection	IP66
Enclosure rating (NEMA)	4 (UL)
	4X (UL)
Impact strength	IK06
Ambient temperature (operation)	-40 °C ... 125 °C

Drawings

Dimensional drawing

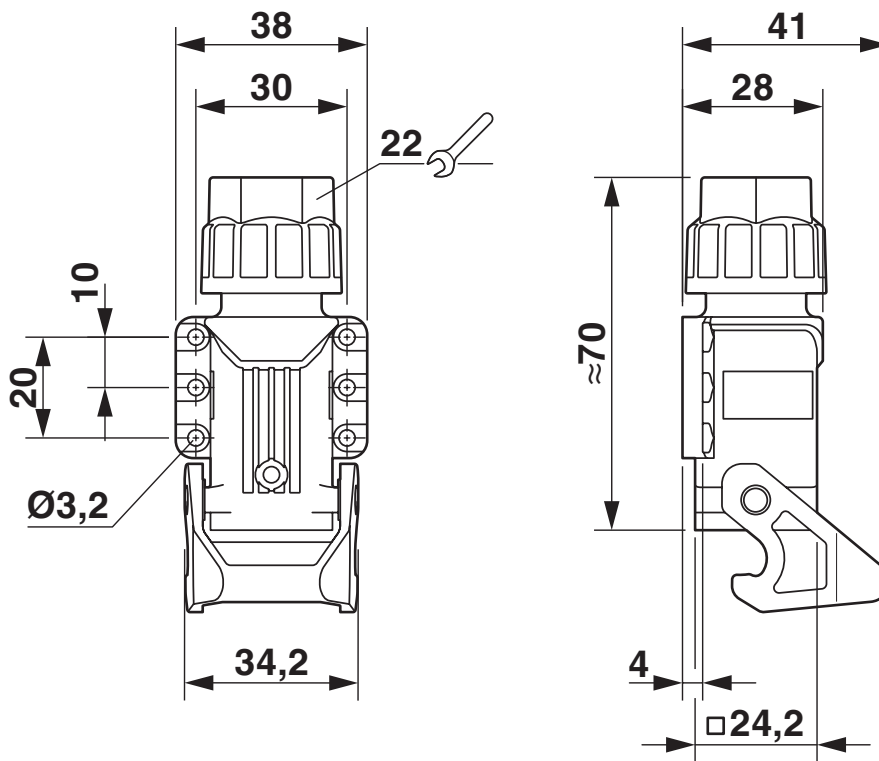

Dimensional drawing

1419268

<https://www.phoenixcontact.com/au/products/1419268>

Approvals

To download certificates, visit the product detail page: <https://www.phoenixcontact.com/au/products/1419268>

DNV

Approval ID: TAE000037S



cULus Recognized

Approval ID: E468743

1419268

<https://www.phoenixcontact.com/au/products/1419268>

Classifications

ECLASS

ECLASS-13.0

27440202

ETIM

ETIM 9.0

EC000437

UNSPSC

UNSPSC 21.0

31261500

1419268

<https://www.phoenixcontact.com/au/products/1419268>

Environmental product compliance

EU RoHS

Fulfills EU RoHS substance requirements	Yes, No exemptions
---	--------------------

China RoHS

Environment friendly use period (EFUP)	EFUP-E
	No hazardous substances above the limits

EU REACH SVHC

REACH candidate substance (CAS No.)	No substance above 0.1 wt%
-------------------------------------	----------------------------

Phoenix Contact 2025 © - all rights reserved
<https://www.phoenixcontact.com>

PHOENIX CONTACT PTY Ltd
Unit 7, 2-8 South Street
Rydalmere NSW 2116
1300 786 411
customerservice@phoenixcontact.com.au