

# HC-STA-B16-SHWS-2SSM25-ELC-AL - Housing



1082586

<https://www.phoenixcontact.com/au/products/1082586>

Please be informed that the data shown in this PDF document is generated from our online catalog. Please find the complete data in the user documentation. Our general terms of use for downloads are valid.



Surface mounting housing B16, with single locking latch, material: Die-cast aluminum, salt water resistant, cable outlets: 2, lateral, 2x M25, height: 84.7 mm, cable gland: none, Standard

## Your advantages

- Good shielding in the event of electromagnetic interference

## Commercial data

Item number	1082586
Packing unit	1 pc
Minimum order quantity	1 pc
Sales key	AF7APB
Product key	AF7APB
Catalog page	Page 619 (C-2-2019)
GTIN	4055626816234
Weight per piece (including packing)	398.3 g
Weight per piece (excluding packing)	22.22 g
Customs tariff number	85389099
Country of origin	CN

# HC-STA-B16-SHWS-2SSM25-ELC-AL - Housing



1082586

<https://www.phoenixcontact.com/au/products/1082586>

## Technical data

### Notes

General	For contact inserts HC-B16, BB32, D40, DD72, HS6, HV6, M, K
---------	---

### Product properties

Product type	Housing with locking latch
Housing type	Surface mounting housing
Application	Standard
Type	B16
No. of cable outlets	2
Type of the screw connection	2x M25
Type	Tall design
Cable outlet	lateral
Pg screw connection	none

### Dimensions

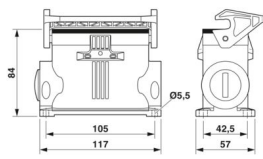
Dimensional drawing	
Width	57 mm
Height	84.7 mm
Length	117.5 mm
Hole diameter	5.5 mm

### Material specifications

Flammability rating according to UL 94	V0 (Interlock)
Seal material	NBR, conductive
Housing material	Die-cast aluminum, salt water resistant
Housing surface material	uncoated
Locking latch material	PA

### Mechanical properties

#### Mechanical data

Type of the screw connection	2x M25
Locking type	Latch

### Connection data

Tightening torque	2 Nm ... 3 Nm (for M5 mounting screws on the surface-mount housing)
-------------------	---

### Mounting

# HC-STA-B16-SHWS-2SSM25-ELC-AL - Housing



1082586

<https://www.phoenixcontact.com/au/products/1082586>

Assembly note	One opening is sealed with a plastic filler plug and can be opened using a screwdriver.
---------------	---

## Environmental and real-life conditions

### Ambient conditions

Degree of protection	IP66
	IP67
Enclosure rating (NEMA)	4 (UL 50e)
	4X (UL 50e)
	12 (UL 50e)
Impact strength	IK08
Ambient temperature (operation)	-40 °C ... 125 °C

# HC-STA-B16-SHWS-2SSM25-ELC-AL - Housing



1082586

<https://www.phoenixcontact.com/au/products/1082586>

## Drawings

Dimensional drawing

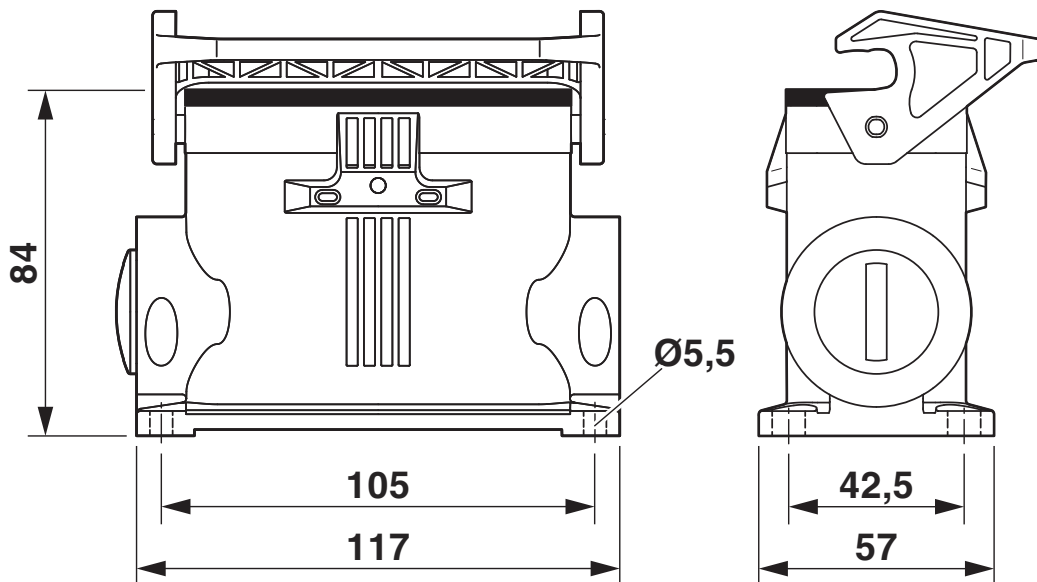

Dimensional drawing

1082586

<https://www.phoenixcontact.com/au/products/1082586>

## Approvals

🔗 To download certificates, visit the product detail page: <https://www.phoenixcontact.com/au/products/1082586>

**DNV**

Approval ID: TAE000037S



**cUL Recognized**

Approval ID: E255026



**UL Recognized**

Approval ID: E255026

# HC-STA-B16-SHWS-2SSM25-ELC-AL - Housing



1082586

<https://www.phoenixcontact.com/au/products/1082586>

## Classifications

### ECLASS

ECLASS-13.0

27440202

### ETIM

ETIM 9.0

EC000437

### UNSPSC

UNSPSC 21.0

31261500

# HC-STA-B16-SHWS-2SSM25-ELC-AL - Housing



1082586

<https://www.phoenixcontact.com/au/products/1082586>

## Environmental product compliance

### EU RoHS

Fulfills EU RoHS substance requirements	Yes, No exemptions
---	--------------------

### China RoHS

Environment friendly use period (EFUP)	EFUP-E
	No hazardous substances above the limits

### EU REACH SVHC

REACH candidate substance (CAS No.)	No substance above 0.1 wt%
-------------------------------------	----------------------------

Phoenix Contact 2025 © - all rights reserved  
<https://www.phoenixcontact.com>

PHOENIX CONTACT PTY Ltd  
Unit 7, 2-8 South Street  
Rydalmere NSW 2116  
1300 786 411  
[customerservice@phoenixcontact.com.au](mailto:customerservice@phoenixcontact.com.au)