

# HC-STA-B10-SLWSC-2SSM25-ELC-AL - Housing



1412845

<https://www.phoenixcontact.com/au/products/1412845>

Please be informed that the data shown in this PDF document is generated from our online catalog. Please find the complete data in the user documentation. Our general terms of use for downloads are valid.



Surface mounting housing B10, with single locking latch, material: Die-cast aluminum, salt water resistant, protective cover material: PC, cable outlets: 2, lateral, 2x M25, height: 54.6 mm, cable gland: none, protective cover: yes, Standard

## Your advantages

- Good shielding in the event of electromagnetic interference

## Commercial data

Item number	1412845
Packing unit	1 pc
Minimum order quantity	1 pc
Sales key	AF7APB
Product key	AF7APB
Catalog page	Page 605 (C-2-2019)
GTIN	4055626061023
Weight per piece (including packing)	225.3 g
Weight per piece (excluding packing)	222.3 g
Customs tariff number	85389099
Country of origin	CN

1412845

<https://www.phoenixcontact.com/au/products/1412845>

## Technical data

### Notes

General	For contact inserts HC-B10, BB18, DD42, M, K8/24
General	also available as a powder-coated or color version: 1372605 HC-STA-B10-SLWSC-2SSM25-EL/.../...

### Product properties

Product type	Housing with locking latch
Housing type	Surface mounting housing
Application	Standard
Type	B10
No. of cable outlets	2
Type of the screw connection	2x M25
Type	Low design
Protective cover	yes
Cable outlet	lateral
Pg screw connection	none

### Dimensions

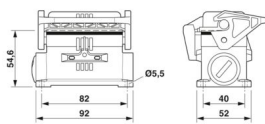
Dimensional drawing	
Width	52 mm
Height	54.6 mm
Length	92 mm
Hole diameter	5.5 mm

### Material specifications

Flammability rating according to UL 94	V0 (Interlock)
	V0 (Protective cover)
Seal material	NBR, conductive
Housing material	Die-cast aluminum, salt water resistant
Housing surface material	uncoated
Material, protective cover	PC
Locking latch material	PA

### Mechanical properties

#### Mechanical data

Type of the screw connection	2x M25
Locking type	Latch

1412845

<https://www.phoenixcontact.com/au/products/1412845>

## Connection data

Tightening torque	2 Nm ... 3 Nm (for M5 mounting screws on the surface-mount housing)
-------------------	---

## Mounting

Assembly note	One opening is sealed with a plastic filler plug and can be opened using a screwdriver.
---------------	---

## Environmental and real-life conditions

### Ambient conditions

Degree of protection	IP66 (with locked protective cover) IP67 (when plugged in)
Enclosure rating (NEMA)	4 (UL 50e) 4X (UL 50e) 12 (UL 50e)
Impact strength	IK08
Ambient temperature (operation)	-40 °C ... 125 °C

1412845

<https://www.phoenixcontact.com/au/products/1412845>

## Drawings

Dimensional drawing

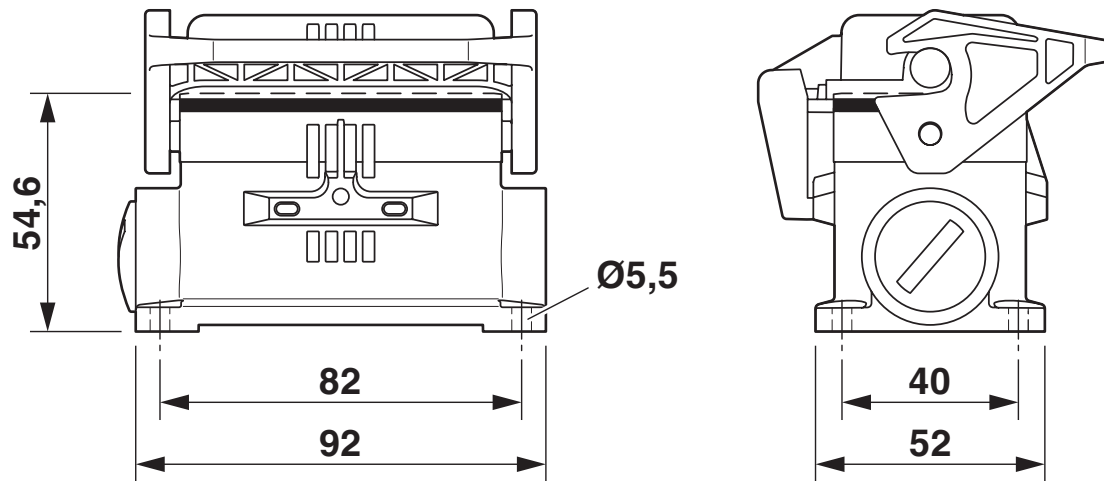

Dimensional drawing

1412845

<https://www.phoenixcontact.com/au/products/1412845>

## Approvals

 To download certificates, visit the product detail page: <https://www.phoenixcontact.com/au/products/1412845>

**DNV**

Approval ID: TAE000037S

**ENEC**

**EAC**

Approval ID: RU C-DE.AI30.B.01102

1412845

<https://www.phoenixcontact.com/au/products/1412845>

## Classifications

### ECLASS

ECLASS-13.0

27440202

### ETIM

ETIM 9.0

EC000437

### UNSPSC

UNSPSC 21.0

31261500

1412845

<https://www.phoenixcontact.com/au/products/1412845>

## Environmental product compliance

### EU RoHS

Fulfills EU RoHS substance requirements	Yes, No exemptions
---	--------------------

### China RoHS

Environment friendly use period (EFUP)	EFUP-E
	No hazardous substances above the limits

### EU REACH SVHC

REACH candidate substance (CAS No.)	No substance above 0.1 wt%
-------------------------------------	----------------------------

### EF3.0 Climate Change

CO2e kg	4.587 kg CO2e
---------	---------------

Phoenix Contact 2025 © - all rights reserved  
<https://www.phoenixcontact.com>

PHOENIX CONTACT PTY Ltd  
Unit 7, 2-8 South Street  
Rydalmere NSW 2116  
1300 786 411  
[customerservice@phoenixcontact.com.au](mailto:customerservice@phoenixcontact.com.au)